



# गणित Mathematics

कक्षा / Class X  
2025-26

विद्यार्थी सहायक सामग्री  
Student Support Material

## संदेश

विद्यालयी शिक्षा में शैक्षिक उत्कृष्टता प्राप्त करना एवं नवाचार द्वारा उच्च - नवीन मानक स्थापित करना केन्द्रीय विद्यालय संगठन की नियमित कार्यप्रणाली का अविभाज्य अंग है। राष्ट्रीय शिक्षा नीति 2020 एवं पी. एम. श्री विद्यालयों के निर्देशों का पालन करते हुए गतिविधि आधारित पठन-पाठन, अनुभवजन्य शिक्षण एवं कौशल विकास को समाहित कर, अपने विद्यालयों को हमने ज्ञान एवं खोज की अद्भुत प्रयोगशाला बना दिया है। माध्यमिक स्तर तक पहुँच कर हमारे विद्यार्थी सैद्धांतिक समझ के साथ-साथ, रचनात्मक, विश्लेषणात्मक एवं आलोचनात्मक चिंतन भी विकसित कर लेते हैं। यही कारण है कि वह बोर्ड कक्षाओं के दौरान विभिन्न प्रकार के मूल्यांकनों के लिए सहजता से तैयार रहते हैं। उनकी इस यात्रा में हमारा सतत योगदान एवं सहयोग आवश्यक है - केन्द्रीय विद्यालय संगठन के पाँचों आंचलिक शिक्षा एवं प्रशिक्षण संस्थान द्वारा संकलित यह विद्यार्थी सहायक- सामग्री इसी दिशा में एक आवश्यक कदम है। यह सहायक सामग्री कक्षा 9 से 12 के विद्यार्थियों के लिए सभी महत्वपूर्ण विषयों पर तैयार की गयी है। केन्द्रीय विद्यालय संगठन की विद्यार्थी सहायक- सामग्री अपनी गुणवत्ता एवं परीक्षा संबंधी सामग्री संकलन की विशेषज्ञता के लिए जानी जाती है और शिक्षा से जुड़े विभिन्न मंचों पर इसकी सराहना होती रही है। मुझे विश्वास है कि यह सहायक सामग्री विद्यार्थियों की सहयोगी बनकर निरंतर मार्गदर्शन करते हुए उन्हें सफलता के लक्ष्य तक पहुँचाएगी।

शुभाकांक्षा सहित ।

**निधि पांडे**

**आयुक्त , केन्द्रीय विद्यालय संगठन**

# PATRON

Smt. NIDHI PANDEY

COMMISSIONER, KVS

# CO-PATRON

Dr. P. DEVAKUMAR

ADDITIONAL COMMISSIONER (ACAD.), KVS (HQ)

# CO-ORDINATOR

Ms. CHANDANA MANDAL

JOINT COMMISSIONER (TRAINING), KVS (HQ)

# COVER DESIGN

KVS PUBLICATION SECTION

# EDITOR

Ms. MENAXI JAIN

DIRECTOR, ZIET MYSURU

## LIST OF TEACHERS AND OTHER OFFICIALS INVOLVED IN THE PREPARATION OF STUDENT SUPPORT MATERIAL

<b>ACADEMIC COORDINATOR</b>	<b>Mr. G. KISHORE</b>	<b>PRINCIPAL, PM SHRI KV NO 1, SRIVIJAYANAGAR, HYDERABAD REGION</b>
<b>ZIET COORDINATOR</b>	<b>Mr. D. SREENIVASULU</b>	<b>TRAINING ASSOCIATE MATHEMATICS, ZIET MYSURU</b>
<b>EDITED AND COMPILED BY</b>	<b>Mrs. P S KAVITHA</b>	<b>TGT(MATHS) K V DRDO, BENGALURU REGION</b>
	<b>Mrs. MINI SEKHAR S</b>	<b>TGT(MATHS) PM SHRI KV No.1, PALAKKAD ERNAKULAM REGION</b>

### CONTENT CREATORS

S.NO	Name of the TEACHER (Ms/Mrs/Mr)	Name of KV	Region
1	JITENDRA KUMAR CHANDRAKAR	PM SHRI KV MAHASAMUND	RAIPUR
2	Dr. MRIDULA CHATURVEDI	PM SHRI KV RAJNANDGAON	RAIPUR
3	P BHASKAR GOUD	PM SHRI KV AFS BEGUMPET	HYDERABAD
4	P. MADHAVI	PM SHRI KV No. 2, AIR FORCE ACADEMY, DUNDIGAL	HYDERABAD
5	R RAVI KUMAR	PM SHRI KV No.1, NAUSENABAUGH, VISKAHAPATNAM	HYDERABAD
6	N VENKATESULU	PM SHRI KV BALLARI	BENGALURU
7	ARCHANA C	PM SHRI KV ASC CENTRE	BENGALURU
8	BINDU GOPAKUMAR	KV DRDO	BENGALURU
9	REMYA GOPI E P	PM SHRI KV KANNUR	ERNAKULUM
10	C MUNISH KUMAR	PM SHRI KV 1 S-1 TIRUPATI	HYDERABAD
11	R V S N RAJU	PM SHRI KV VIZIANAGARAM	HYDERABAD
12	T V DIVYA	PM SHRI KV NO 2 MANGALURU	BENGALURU

<b>REVIEWED BY</b>	1. Dr. MRIDULA CHATURVEDI, TGT(MATHS), PM SHRI KV RAJNANDGAON, RAIPUR REGION
	2. Mrs. BINDU GOPAKUMAR, TGT(MATHS), KV DRDO, BENGALURU REGION

## **INDEX**

<b>S.NO</b>	<b>NAME OF CHAPTER</b>	<b>PAGE NO.</b>
1.	REAL NUMBERS	1
2.	POLYNOMIALS	8
3.	PAIR OF LINEAR EQUATIONS IN TWO VARIABLES	17
4.	QUADRATIC EQUATIONS	25
5.	ARITHMETIC PROGRESSIONS	35
6.	TRIANGLES	44
7.	COORDINATE GEOMETRY	53
8.	INTRODUCTION TO TRIGONOMETRY	60
9.	APPLICATIONS OF TRIGONOMETRY	71
10.	CIRCLES	83
11.	AREAS RELATED TO CIRCLES	94
12.	SURFACE AREAS AND VOLUMES	106
13.	STATISTICS	116
14.	PROBABILITY	131
15.	EXERCISES AND ANSWERS (ALL CHAPTERS)	143
16.	SAMPLE QUESTION PAPERS (STANDARD) – 1 TO 4	143
17.	SAMPLE QUESTION PAPERS (BASIC) – 1 TO 4	143
18.	USEFUL LINKS	144

# CHAPTER-1 REAL NUMBERS MIND MAPPING

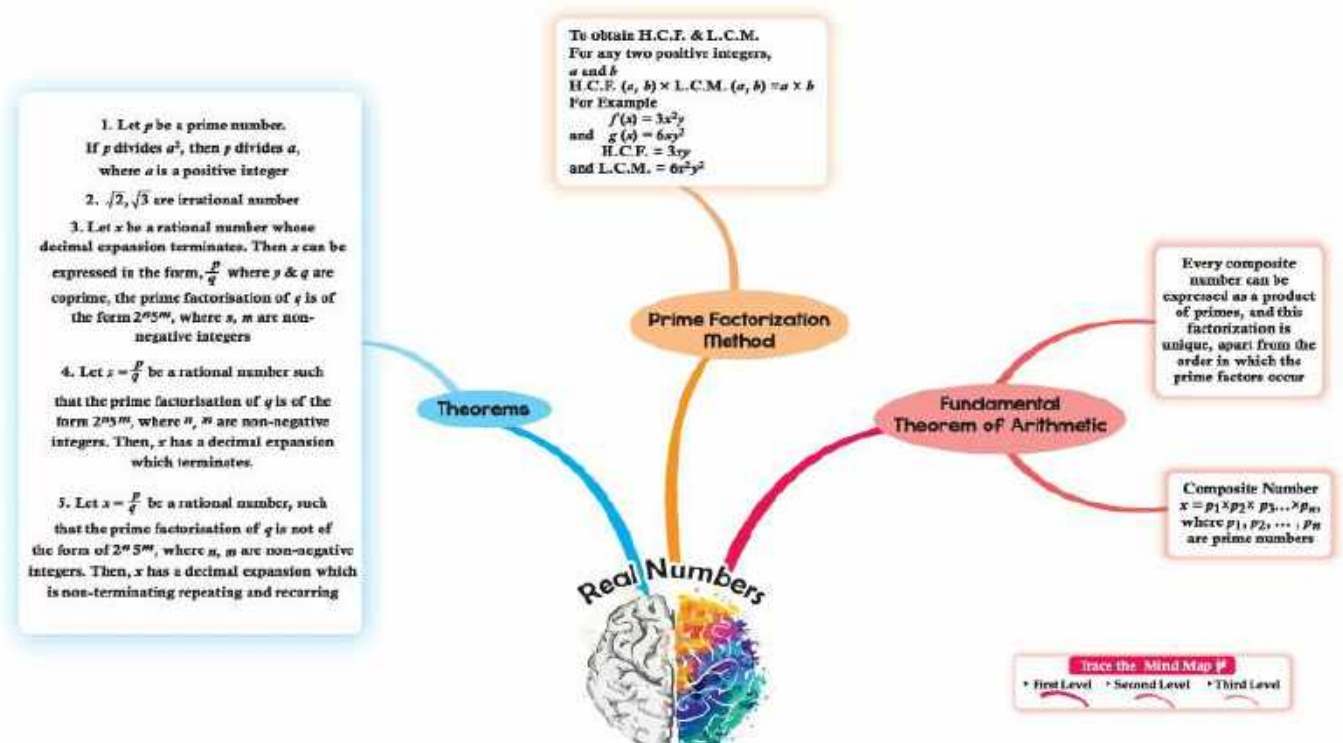

## GIST OF THE CHAPTER

- Real Numbers: Include both rational and irrational numbers.
- Fundamental Theorem of Arithmetic: Every Composite number can be expressed as a product of primes, and the factorisation is unique except for the order of the prime factors.
- Prime Factorization Applications: Useful for finding HCF and LCM.
- Rational Numbers
- Irrational numbers and its properties.

## DEFINITION

- Real Numbers: Set of numbers that can be represented on number line. Include both rational numbers and irrational numbers.
- Natural numbers (1, 2, 3,.....), Whole numbers (0, 1, 2, 3,.....), Integers (....., -2, -1, 0, 1, 2, ....)
- Rational numbers: Number that can be expressed in the form of  $\frac{p}{q}$  where  $q \neq 0$
- Irrational numbers: Numbers that cannot be expressed as  $\frac{p}{q}$ , like  $\pi, \sqrt{2}$

## FORMULA

### **HCF AND LCM FORMULA (For two numbers)**

$HCF \times LCM = \text{Product of two numbers}$

$HCF (a, b) \times LCM (a, b) = a \times b$

### **HCF AND LCM FORMULA (For three numbers)**

$HCF (a, b, c) = HCF (HCF (a, b), c)$

$LCM (a, b, c) = LCM (LCM (a, b), c)$

Step 1: Find HCF /LCM of any two numbers (say,  $a$  and  $b$ )

Step 2: Find HCF/LCM of that result with the third number ( $c$ ).

### MULTIPLE CHOICE QUESTIONS (1 MARK QUESTIONS)

1. The HCF and the LCM of 12, 21, 15 respectively is  
(a) 3, 140                      (b) 12, 420                      (c) 3, 420                      (d) 420, 3  
**Ans.** (c) 3, 420
2. The correct prime factorisation of 98 is  
(a)  $2^2 \times 7$                       (b)  $2^3 \times 7$                       (c)  $2^2 \times 7^2$                       (d)  $2 \times 7^2$   
**Ans.** (d)  $2 \times 7^2$
3. The greatest possible speed at which a man can walk 135 km and 225 km in exact number of hours is:  
(a) 5 km/hr                      (b) 15 km/hr                      (c) 65 km/hr                      (d) 45 km/hr  
**Ans.** (d) 45 km/hr
4. The expression  $1 \times 2 \times 3 \times 7 \times 11 + 1$  is a  
(a) Prime no.                      (b) Composite no.                      (c) Square number                      (d) Neither prime nor composite  
**Ans.** (b) Composite no.
5. Which of the following is an incorrect statement?  
(a)  $\pi$  is an irrational                      (b) 2 is a rational  
(c) Every rational number is a real number                      (d) Every real number is a rational number  
**Ans.** (d) Every real number is a rational number
6. LCM of smallest prime number and smallest 2 digit number is  
(a) 2                      (b) 4                      (c) 10                      (d) 20  
**Ans.** (c) 10
7. If  $a = p^2q$  and  $b = pq^2$  then LCM will be?  
(a)  $p^2q^2$                       (b)  $pq$                       (c)  $pq^2$                       (d)  $pq^3$   
**Ans.** (a)  $p^2q^2$
8. Find the product of HCF and LCM of (32, 28) using relationship between HCF and LCM of two numbers  
(a) 256                      (b) 840                      (c) 832                      (d) 896  
**Ans.** (d) 896
9. If  $a = x^3y^2z^2$ ,  $b = x^2y^2z^3$ , and  $c = x^3y^2z^n$  and the LCM (a, b, c) =  $x^3y^2z^5$  then the value of n is:  
(a) 3                      (b) 2                      (c) 5                      (d) 1  
**Ans.** (c) 5
10. The largest number that will divide 445, 572 and 699 leaving remainders 4, 5 and 6 respectively is:  
(a) 63                      (b) 36                      (c) 34                      (d) 45  
**Ans.** (a) 63

### ASSERTION AND REASONING QUESTIONS

**Directions:** In the following questions, a statement of assertion is followed by a statement of reason. Mark the correct choice as:

- (a) Both Assertion (A) and Reason (R) are true and Reason (R) is the correct explanation of Assertion (A).  
(b) Both Assertion (A) and Reason (R) are true but Reason (R) is not the correct explanation of Assertion (A).  
(c) Assertion (A) is true but Reason (R) is false.  
(d) Assertion (A) is false but Reason (R) is true
1. **Assertion(A):** The H.C.F. of two numbers is 16 and their product is 3072. Then their L.C.M. = 162.  
**Reason(R):** If a and b are two positive integers, then  $H.C.F. \times L.C.M. = a \times b$ .  
**Ans.** (d)
2. **Assertion(A):** The HCF of two numbers is 2 and their LCM is 15  
**Reason(R):** HCF is a factor of LCM.  
**Ans.** (d)
3. **Assertion(A):**  $\frac{13}{3125}$  is a terminating decimal fraction.

**Reason(R):** If  $q = 2^n \cdot 5^m$  where  $n$  and  $m$  are non-negative integers, then  $p/q$  is a terminating decimal fraction.

**Ans. (a)**

4. **Assertion(A):** 2 is an example of a rational number.

**Reason(R):** The square roots of all positive integers are irrational numbers.

**Ans. (c)**

5. **Assertion (A):** If the HCF of two numbers is 5 and their product is 150, then their LCM is 40.

**Reason(R):** For any two positive integers  $p$  and  $q$ ,  $\text{HCF}(p, q) \times \text{LCM}(p, q) = p \times q$ .

**Ans. (d)**

6. **Assertion (A):** Every positive even integer is a multiple of 2.

**Reason (R):** The Fundamental Theorem of Arithmetic ensures the unique prime factorization of integers greater than 1.

**Ans. (b)**

7. **Assertion (A):** The decimal expansion of  $\frac{7}{8}$  is terminating.

**Reason (R):** A rational number has a terminating decimal expansion if its denominator has only powers of 2 and/or 5 in prime factorization.

**Ans. (a)**

8. **Assertion (A):**  $\sqrt{5}$  is an irrational number.

**Reason (R):** The square root of any non-perfect square natural number is irrational.

**Ans. (a)**

9. **Assertion (A):** If the HCF of two numbers is 1, they are said to be co-prime.

**Reason (R):** The LCM of two co-prime numbers is always equal to their product.

**Ans. (a)**

10. **Assertion (A):** The decimal expansion of  $\frac{1}{6}$  is non-terminating and repeating.

**Reason (R):** A rational number has a non-terminating repeating decimal if the denominator has prime factors other than 2 or 5.

**Ans. (a)**

### **VERY SHORT ANSWER TYPE QUESTIONS (2MARKS QUESTIONS)**

1. Prove that  $\sqrt{3}$  is an Irrational number.

**Ans.** Let us assume that  $\sqrt{3}$  is a rational number,  $\sqrt{3} = \frac{a}{b}$ , where  $a$  and  $b$  are co-primes. Squaring

both side  $(\sqrt{3})^2 = a^2 / b^2$

$3b^2 = a^2$ , (3 divides  $a^2$ , 3 divides  $a$ ) Let us consider  $a = 3c$ , by putting the value of  $a$  we get  $b^2 = 3c^2$  (3 divides  $b^2$ , 3 divides  $b$ ). so 3 is a common factor of both  $a$  and  $b$ , which is a contradict our assumption, Hence,  $\sqrt{3}$  is an Irrational

2. Find the HCF and LCM of smallest prime number and smallest composite number.

**Ans.** HCF=2, LCM=4

3. The HCF and LCM of two numbers are 9 and 360 respectively. If one number is 45 find the other number.

**Ans.**  $\text{HCF} \times \text{LCM} = \text{Product of two nos.}$  so the other no. is 72.

4. If product of two coprime numbers is 217, then find their LCM.

**Ans.** LCM=217

5. Explain Why  $(17 \times 11 \times 2 + 17 \times 11 \times 5)$  is a composite number?

**Ans.** Given no. is a product of more than two prime nos.

6. Find the LCM and HCF of 8 and 64

**Ans.** LCM=64, HCF=8

7. Given that  $\text{HCF}(252, 594) = 18$ , find  $\text{LCM}(252, 594)$ .

**Ans.** LCM= 8316

8. Find the prime factorization of 2120.

**Ans.**  $2^3 \times 5 \times 53$ .

9. Show that any number of the form  $4^n$  can never end with the digit 0.

**Ans:** If  $4^n$  ends with 0 then it must have 5 as a factor. But we know the only prime factor of  $4^n$  is 2. Also, we know from the fundamental theorem of arithmetic that prime factorization of each number is unique. Hence  $4^n$  can never end with the digit 0.

10. Two numbers are in the ratio of 15:11. If their H.C.F. is 13, then find the numbers.

**Ans.** The first no. = HCF  $\times$  first ratio =  $13 \times 15 = 195$

The second no. = HCF  $\times$  first ratio =  $13 \times 11 = 143$

### **SHORT ANSWER TYPE QUESTIONS (3 MARKS QUESTIONS)**

1. Find the largest number that will divide 398, 436 and 542 leaving remainders 7, 11, and 15 respectively.

**Ans:**  $398 - 7 = 391$ ,  $436 - 11 = 425$ ,  $542 - 15 = 527$ ,

HCF of 391, 425, 527 = 17

2. On a morning walk, three persons step off together and their steps measure 40 cm, 42 cm and 45 cm respectively. What is the minimum distance each should walk so that each can cover the same distance in complete steps?

**Ans:** Minimum distance = LCM of 40, 42, 45 = 2520

3. The LCM of two numbers is 14 times their HCF. The sum of LCM and HCF is 600. If one number is 280 then find other number.

**Ans:** HCF  $\times$  LCM = product of two nos., LCM =  $14 \times$  HCF

it is given that HCF + LCM = 600, by using the above we get HCF = 40 and the other no. is = 80.

4. Find the least positive integer which is divisible by first 5 natural numbers.

**Ans:** The first five natural nos. are 1, 2, 3, 4, 5. The least positive integer divisible by the first 5 natural nos. is 60.

5. Show that  $(\sqrt{3} + \sqrt{5})^2$  is an irrational number, if  $\sqrt{15}$  is irrational number?

**Ans:** By using the formula of  $(a + b)^2$  we get  $8 + 2\sqrt{15}$ . We know that the sum of rational and irrational is always irrational.

6. An army contingent of 616 members is to march behind an army band of 32 members in a parade. The two groups are to march in the same number of columns. What is the maximum number of columns in which they can march?

**Ans:** HCF (616, 32) will give the maximum number of columns in which they can march.

$616 = 2^3 \times 7^1 \times 11^1$ ,  $32 = 2^5$  The HCF (616, 32) =  $2^3 = 8$ .

Therefore, they can march in 8 columns each. Type equation here.

7. Prove that  $3 + 2\sqrt{5}$  is irrational.

**Ans:** Let us assume on the contrary that  $3 + 2\sqrt{5}$  is rational.

Then, there exist co-prime positive integers a and b such that  $3 + 2\sqrt{5} = \frac{a}{b}$

$$\Rightarrow 2\sqrt{5} = \frac{a}{b} - 3 \Rightarrow \sqrt{5} = \frac{a-3b}{2b}$$

Since, a and b are integers and thus  $\frac{a-3b}{2b}$  is rational number. Thus  $\sqrt{5}$  is rational

But this contradicts the fact that  $\sqrt{5}$  is irrational. So, our assumption is incorrect.

Hence,  $3 + 2\sqrt{5}$  is an irrational number.

8. Prove that  $5 - \sqrt{3}$  is an irrational number.

**Ans:** Let us assume on the contrary that  $5 - \sqrt{3}$  is rational.

Then, there exist co-prime positive integers a and b such that  $5 - \sqrt{3} = \frac{a}{b}$

$$\Rightarrow 5 - \frac{a}{b} = \sqrt{3} \Rightarrow \frac{5b-a}{b} = \sqrt{3}$$

Since, a and b are integers and thus  $\frac{5b-a}{b}$  is rational number.

Thus  $\sqrt{3}$  is rational but this contradicts the fact that  $\sqrt{3}$  is irrational. So, our assumption is incorrect.

Hence,  $5 - \sqrt{3}$  is an irrational number.

9. Three bells toll at intervals of 9, 12, 15 minutes respectively. If they start tolling together, after

what time will they next toll together?

**Ans:**  $9 = 3^2$ ,  $12 = 2^2 \times 3$ ,  $15 = 3 \times 5$ ,  $\text{LCM} = 2^2 \times 3^2 \times 5 = 4 \times 9 \times 5 = 180$  minutes or 3 hours

They will next toll together after 3 hours.

10. Two tankers contain 850 liters and 680 liters of petrol. Find the maximum capacity of a container which can measure the petrol of each tanker in the exact number of times.

**Ans:** To find the maximum capacity of a container which can measure the petrol of each tanker in the exact number of times, we find the HCF of 850 and 680.

$$850 = 2 \times 5^2 \times 17, 680 = 2^3 \times 5 \times 17$$

$\text{HCF} = 2 \times 5 \times 17 = 170$ , Maximum capacity of the container = 170 liters.

### **LONG ANSWER TYPE QUESTIONS (5 MARK QUESTIONS)**

1. The traffic light at three consecutive different road crossing change after every 48 seconds, 72 seconds and 108 seconds respectively. If they change simultaneously at 7am, at what time will they change simultaneously again?

**Ans:** Here we have to find the LCM of 48, 72 and 108 first then, convert the LCM from seconds to minutes and seconds. Finally, add the result to 7:00 am. The traffic lights will change simultaneously again at 7:07: 12 am.

2. The length, breadth, and height of a room are 8 m 50 cm, 6 m 25 cm and 4 m 75 cm respectively. Find the length of the longest rod that can measure the dimensions of the room exactly.

**Ans:** To find the length of the longest rod that can measure the dimensions of the room exactly, we have to find HCF.

$$L, \text{ Length} = 8 \text{ m } 50 \text{ cm} = 850 \text{ cm} = 2^1 \times 5^2 \times 17$$

$$B, \text{ Breadth} = 6 \text{ m } 25 \text{ cm} = 625 \text{ cm} = 5^4$$

$$H, \text{ Height} = 4 \text{ m } 75 \text{ cm} = 475 \text{ cm} = 5^2 \times 19$$

$$\text{HCF of L, B and H is } 5^2 = 25 \text{ cm}$$

$$\text{Length of the longest rod} = 25 \text{ cm}$$

3. In a school, there are two Sections A and B of class X. There are 48 students in Section A and 60 students in Section B. Determine the least number of books required for the library of the school so that the books can be distributed equally among all students of each Section.

**Ans:** Since the books are to be distributed equally among the students of Section A and Section B. therefore, the number of books must be a multiple of 48 as well as 60.

Hence, required no. of books is the LCM of 48 and 60.

$$48 = 2^4 \times 3, 60 = 2^2 \times 3 \times 5$$

$$\text{LCM} = 2^4 \times 3 \times 5 = 16 \times 15 = 240,$$

Hence, required number of books is 240.

4. There are 104 students in class X and 96 students in class IX in a school. In a house examination, the students are to be evenly seated in parallel rows such that no two adjacent rows are of the same class.

(a) Find the maximum number of parallel rows of each class for the seating arrangement.

(b) Also, find the number of students of class IX and also of class X in a row.

(c) What is the objective of the school administration behind such an arrangement?

**Ans:** The HCF of 104 and 96 is 8. (a) The maximum number of parallel rows of each class is 8

(b) The number of students of class IX in a row is 12, and the number of students of class X in a row is 13.

(c) The objective of school administration behind such an arrangement is fair and clean examination, so that no student can take help from any other student of his/her class.

5. Dudhnath has two vessels containing 720 ml and 405 ml of milk respectively. Milk from these containers is poured into glasses of equal capacity to their brim. Find the minimum number of glasses that can be filled.

**Ans:** 1st vessel = 720 ml; 2nd vessel = 405 ml

We find the HCF of 720 and 405 to find the maximum quantity of milk to be filled in one glass.

$$405 = 3^4 \times 5$$

$$720 = 2^4 \times 3^2 \times 5$$

$$\text{HCF} = 3^2 \times 5 = 45 \text{ ml} = \text{Capacity of glass}$$

$$\text{No. of glasses filled from 1st vessel} = 720/45 = 16$$

$$\text{No. of glasses filled from 2nd vessel} = 405/45 = 9$$

$$\text{Total number of glasses} = 25$$

### CASE BASED QUESTIONS (4 MARKS QUESTIONS)

1. A garden consists of 135 rose plants planted in certain number of columns. There is another set of 225 marigold plants, which is to be planted in the same number of columns.



Read carefully the above paragraph and answer the following question

(i) Find the maximum number of columns in which they can be planted, also find the total number of plants.

(ii) Find the sum of exponents of the prime factors of the maximum number of columns in which they can be planted.

(iii) What is the total number of rows in which they can be planted.

**Ans:** (i) 45 and 360      (ii) 3      (iii) 8

2. To enhance the reading skills of grade X students, the school nominates you and two of your friends to set up a class library. There are two sections- section A and section B of grade X. There are 32 students in section A and 36 students in section B



(i) What is the minimum number of books you will acquire for the class library, so that they can be distributed equally among students of Section A or Section B?

(ii) If the product of two positive integers is equal to the product of their HCF and LCM is true then, the HCF (32, 36) is

(iii) Express 36 as a product of its primes.

**Ans:** (i) 288      (ii) 4      (iii)  $2^2 \times 3^2$

3. Raman considers eating nutritious food as an important part of his daily life. So on his birthday he decides to avoid junk food and plans to serve fruit to his friends. He has 60 bananas and 36 apples, which are to be distributed equally to his friends. Now answer the following:

(i) How many friends can he invite?

(ii) How many apples will each guest get?

(iii) Find the LCM of 60 and 36.

**Ans:** (i) 12                      (ii) 3                      (iii) 180

4. A Mathematics Exhibition is being conducted in your School and one of your friends is making a model of a factor tree. He has some difficulty and asks for your help in completing a quiz for the audience.

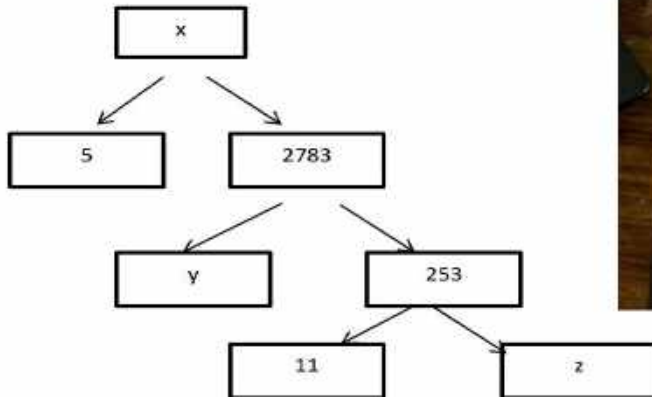

Observe the following factor tree and answer the following:

- (i) What will be the value of x?
- (ii) What will be the value of y?
- (iii) What will be the value of z?
- (iv) Find the prime factorisation of 13915.

**Ans:** (i) 13915                      (ii) 11                      (iii) 23                      (iv)  $5 \times 11^2 \times 23$ .

5. A seminar is being conducted by an Educational Organisation, where the participants will be educators of different subjects. The number of participants in Hindi, English and Mathematics are 60, 84 and 108 respectively.



- (i) In each room the same number of participants are to be seated and all of them being in the same subject, hence find the maximum number participants that can accommodated in each room.
- (ii) What is the minimum number of rooms required during the event?
- (iii) Find the LCM of 60, 84 and 108.
- (iv) Find the product of HCF and LCM of 60,84 and 108

**Ans:** (i) 12                      (ii) 21                      (iii) 3780                      (iv) 45360.

### **HIGHER ORDER THINKING QUESTION**

1. 144 cartons of Coke cans and 90 cartons of Pepsi cans are to be stacked in a canteen. If each stack is of the same height and is to contain cartons of the same drink, what would be the greatest number of cartons each stack would have?

**Ans:** In this question we have to find the HCF of 144 and 90, which is 18.

## CHAPTER-2 POLYNOMIALS MIND MAPPING:

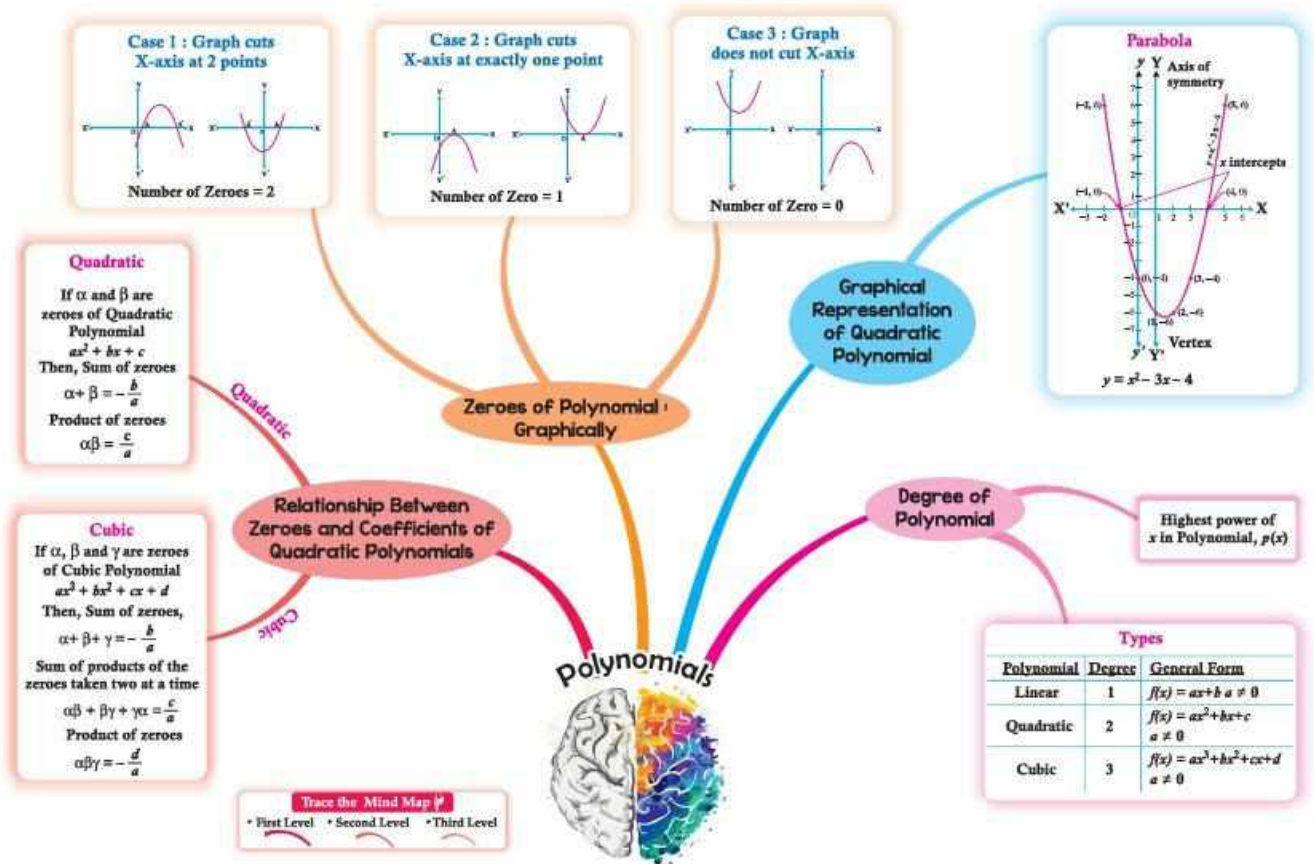

### GIST/SUMMARY OF THE LESSON:

1. An **algebraic expression** is an expression made up of variables and constants along with mathematical operators. An algebraic expression is a sum of terms, which are considered to be building blocks for expressions.

2. **Polynomial** comes from the word 'Poly' (Meaning Many) and 'nomial' (in this case meaning Term)-so it means many terms. A polynomial is made up of terms that are only added, subtracted or multiplied. A polynomial is an algebraic expression in which the exponent on any variable is a whole number.

3. **Degree of a Polynomial** -For a polynomial in one variable – the highest exponent on the variable in a polynomial is the degree of the polynomial.

4. **Types of Polynomials**-Polynomials can be classified based on (a) Number of terms (b) Degree of the polynomial.

(a) Number of terms – Monomial-(one term) Example:  $2x, 6x^2, 9xy$

Binomial – (two unlike terms) Example:  $4x^2 + x, 5x + 4$

Trinomial – (three unlike terms) Example:  $x^2 + 3x + 4$

(b) Degree- Linear Polynomial-(degree is one) Example:  $2x + 1$

Quadratic Polynomial-(degree is two) Example:  $3x^2 + 8x + 5$

Cubic Polynomial-(degree is three) Example:  $2x^3 + 5x^2 + 9x + 15$

5. **Zeroes of a Polynomial** -A zero of a polynomial  $p(x)$  is the value of  $x$  for which the value of  $p(x)$  is 0. If  $k$  is a zero of  $p(x)$ , then  $p(k) = 0$ . Example: For  $p(x) = x^2 - 3x + 2$ , when  $x = 1$ , the value of  $p(x) = 0$ . So, 1 is a zero of  $p(x)$

## 6. Geometrical Representation and meaning of the zeroes of a Polynomial

(a) Linear Polynomial-The graph of a linear polynomial is a straight line. It cuts the X-axis at exactly one point. The number of zero of polynomial is one.

(b) Quadratic Polynomial-The graph of a quadratic polynomial is a parabola. It looks like a U, which either opens upwards (if 'a' is positive) or opens downwards (if 'a' is negative) in  $ax^2+bx+c$ . It can cut the x-axis at zero, one or two points. The number of zero of a quadratic polynomial is at most two.

(c) Cubic Polynomial- The graph is curve which cuts the x-axis at some points. The number of zero of a cubic polynomial is at most three.

## 7. Factorisation of Polynomials

Quadratic polynomials can be factorized by splitting the middle term.

## 8. Relationship between Zeroes and Coefficients of a Polynomial for Quadratic Polynomial:

If  $\alpha$  and  $\beta$  are the roots of a quadratic polynomial  $ax^2+bx+c$ , then,  $\alpha + \beta = \frac{-b}{a}$  and  $\alpha\beta = \frac{c}{a}$

9. If  $\alpha$  and  $\beta$  are the zeroes of a quadratic polynomial, then the polynomial can be formed as  $x^2 - (\text{sum of zeroes})x + (\text{product of zeroes})$   $x^2 - (\alpha + \beta)x + \alpha\beta$

### DEFINITIONS AND FORMULAE:

1. If  $\alpha$  and  $\beta$  are the roots of a quadratic polynomial  $ax^2+bx+c$ , then,  $\alpha + \beta = \frac{-b}{a}$  and  $\alpha\beta = \frac{c}{a}$
2. If  $\alpha$  and  $\beta$  are the zeroes of a quadratic polynomial, then the polynomial can be formed as  $x^2 - (\text{sum of zeroes})x + (\text{product of zeroes})$   $x^2 - (\alpha + \beta)x + \alpha\beta$

### MULTIPLE CHOICE QUESTIONS (1 MARK QUESTIONS)

1. Which of the following is a polynomial?

- (a)  $\frac{1}{x} + 2$                       (b)  $x^2 + 2x + 1$                       (c)  $x^2 + \frac{1}{x} + 1$                       (d)  $x^{-2} + 3x + 2$

**Ans:** (b)

Solution: A polynomial cannot have variables in the denominator or negative powers.

2. What is the degree of the polynomial  $5x^4 + 2x^3 - x + 7$ ?

- (a) 3                      (b) 4                      (c) 5                      (d) 2

**Ans:** (b)

Solution: The highest power of the variable is 4, so the degree is 4.

3. The value of the polynomial  $f(x) = x^2 - 4x + 4$  at  $x = 2$  is:

- (a) 0                      (b) 4                      (c) 2                      (d) -2

**Ans:** (a)

Solution:  $f(2) = (2)^2 - 4(2) + 4 = 4 - 8 + 4 = 0$

4. If one zero of the polynomial  $x^2 + 7x + 12$  is -3, the other is:

- (a) -4                      (b) 4                      (c) 3                      (d) -2

**Ans:** (a)

Solution:  $x^2 + 7x + 12 = (x + 3)(x + 4) \Rightarrow$  Other zero is -4.

5. For the polynomial  $x^2 - 5x + 6$ , the sum of the zeroes is:

- (a) 5                      (b) -5                      (c) 6                      (d) -6

**Answer:** (a)

Solution: Sum =  $\frac{-b}{a} = \frac{-(-5)}{1} = 5$

6. If one zero of the polynomials  $(ax^2 + bx + c)$  is the reciprocal of the other, and  $(a \neq 0)$ , then which of the following must be true?

- (a)  $b = c$                       (b)  $b^2 = 4ac$                       (c)  $c = a$                       (d)  $a = 0$

**Ans:** (c)

Solution: Let the zeroes be  $\alpha$  and  $\frac{1}{\alpha}$ . Their product is 1. Hence,  $\frac{c}{a} = 1 \Rightarrow c = a$

7. If the polynomial  $f(x) = x^3 - 6x^2 + 11x - 6$  is factored completely, which of the following is NOT a zero?

- (a) 1                      (b) 2                      (c) 3                      (d) 4

**Ans:** (d)

**Solution:** Factorization:  $(x-1)(x-2)(x-3)$ . So zeroes are 1, 2, 3. 4 is not a zero.

8. For what value of  $k$  is  $2x^3 + 3x^2 - 2x + k$  divisible by  $(x - 1)$ ?

- (a) -2                      (b) -3                      (c) 1                      (d) 2

**Ans:** (b)

**Solution:** Use Remainder Theorem:  $f(1) = 0 \Rightarrow 2 + 3 - 2 + k = 0 \Rightarrow k = -3$

9. Which of the following quadratic polynomials has zeroes that are equal and real?

- (a)  $x^2 + 2x + 3$               (b)  $x^2 + 4x + 4$               (c)  $x^2 + 3x + 5$               (d)  $x^2 - 2x + 5$

**Ans:** (b)

**Solution:** Discriminant  $D = b^2 - 4ac = 16 - 16 = 0$ , so real and equal roots.

10. If the sum and product of the zeroes of a quadratic polynomial are both equal to 5, which polynomial matches this condition?

- (a)  $x^2 - 5x + 5$               (b)  $x^2 + 5x + 5$               (c)  $x^2 - 10x + 25$               (d)  $x^2 - 5x + 10$

**Ans:** (a)

**Solution:** For sum = product = 5, polynomial is  $x^2 - 5x + 5$

### ASSERTION AND REASONING BASED QUESTIONS

**Directions:** In the following questions, a statement of assertion is followed by a statement of reason. Mark the correct choice as:

- (a) Both assertion and reason are true and reason is the correct explanation of assertion.  
(b) Both assertion and reason are true but reason is not the correct explanation of assertion.  
(c) Assertion is true but reason is false.  
(d) Assertion is false but reason is true.

1. **Assertion(A):** The graph  $y=f(x)$  is shown in figure, for the polynomial  $f(x)$ .

The number of zeroes of  $f(x)$  is 3.

**Reason(R):** The number of zero of the polynomial  $f(x)$  is the number of points of which  $f(x)$  cuts or touches the axes.

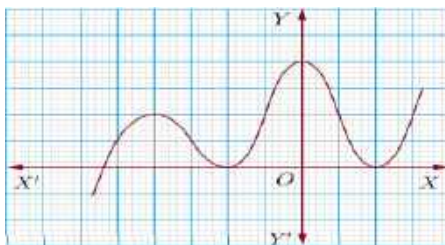

**Ans:** Graph cuts X axis at three points. So (a) is correct option.

2. **Assertion(A):** Both zeroes of the quadratic polynomial  $x^2 - 2kx + 2$  are equal in magnitude but opposite in sign then value of  $k$  is  $\frac{1}{2}$ .

**Reason(R):** Sum of zeroes of a quadratic polynomial  $ax^2 + bx + c$  is  $-\frac{b}{a}$

**Ans.** (d)

3. **Assertion(A):**  $x^2 + 4x + 5$  has two real zeroes.

**Reason(R):** A quadratic polynomial can have at the most two zeroes.

**Ans:** (d)  $p(x) = 0 \Rightarrow x^2 + 4x + 5 = 0$  Discriminant,  $D = b^2 - 4ac = -4 < 0$ , therefore, no real zeroes are there.

4. **Assertion(A):** If the sum of the zeroes of the quadratic polynomial  $x^2 - 2kx + 8$  is 2 then value of  $k$  is 1.

**Reason(R):** Sum of zeroes of a quadratic polynomial  $ax^2 + bx + c$  is  $-\frac{b}{a}$

**Ans :** (a)

5. **Assertion(A):**  $P(x) = 4x^3 - x^2 + 5x^4 + 3$  is a polynomial of degree 3.

**Reason(R):** The highest power of variable is the degree of polynomial.

**Ans:** (d)

6. **Assertion(A)** :  $x^3 + x$  has only one real zero.

**Reason(R):** A polynomial of nth degree must have n real zeroes.

**Ans :** (c)

7. **Assertion(A)** : Degree of zero of polynomial is not defined.

**Reason(R):** Degree of non zero constant polynomial is zero.

**Ans:** (b).

8. **Assertion(A):** If the product of the zeroes of polynomial  $x^2 + 3x + k$  is -10, the value of k is -2

**Reason(R):** Sum of the zeroes of quadratic polynomial  $ax^2 + bx + c$  is  $-\frac{b}{a}$

**Ans :** (d)

9. **Assertion(A)** :  $3 - \sqrt{5}$  is one of the zero of a quadratic polynomial. Then the other zero is  $3 + \sqrt{5}$

**Reason(R):** Irrational zeroes always occur in pairs.

**Ans :** (a)

10. **Assertion(A)** : A quadratic polynomial whose sum of zeroes is 12 and product is 8 is  $x^2 - 20x + 96$

**Reason(R):** If  $\alpha$  and  $\beta$  are zeroes of polynomial, then the polynomial is  $x^2 - (\alpha + \beta)x + \alpha\beta$

**Ans:** (d)

### **VERY SHORT ANSWER TYPE QUESTIONS (2 MARKS QUESTIONS)**

1. Find the value of the polynomial  $p(x) = 5x - 4x^2 + 3$  at  $x = -1$ .

**Solution:** Given polynomial  $p(x) = 5x - 4x^2 + 3$ , Substitute  $x = -1$  in  $p(x)$  we get  $p(-1) = -6$

2. Find the zeroes of the quadratic polynomial  $x^2 - 2x - 8$ .

**Solution:** Let  $p(x) = x^2 - 2x - 8$ . So,  $x - 4 = 0$  or  $x + 2 = 0$ ,  $x = 4$  or  $x = -2$

3. Find a quadratic polynomial whose sum and product of zeroes are  $\frac{1}{4}$  and -1 respectively.

**Solution:** Let the zeroes be  $\alpha$  and  $\beta$ . A quadratic polynomial is given by  $k[x^2 - (\text{sum of zeroes})x + \text{product of zeroes}]$ , where k is a non-zero constant, after substituting the values in the formula we get  $4x^2 - x - 4$

4. If one zero of the polynomial  $p(x) = (k - 1)x^2 + kx + 1$  is -3, then find the value of k.

**Solution:** Given  $p(x) = (k - 1)x^2 + kx + 1$ .

Since -3 is a zero of  $p(x)$ , then  $p(-3) = 0$ . On putting the values we get  $k = \frac{8}{6} = \frac{4}{3}$

5. Find the sum and product of the zeroes of the polynomial  $2x^2 - 8x + 6$ .

**Solution:** Let the polynomial be  $p(x) = 2x^2 - 8x + 6$ .

Comparing this with  $ax^2 + bx + c$ , we have  $a = 2$ ,  $b = -8$ ,  $c = 6$ .

Sum of zeroes  $(\alpha + \beta) = \frac{-b}{a} = \frac{-(-8)}{2} = \frac{8}{2} = 4$ . & Product of zeroes  $(\alpha\beta) = \frac{c}{a} = \frac{6}{2} = 3$ .

6. If  $\alpha$  and  $\beta$  are the zeroes of the polynomial  $x^2 + 7x + 10$ , find the value of  $\frac{1}{\alpha} + \frac{1}{\beta}$

**Solution:** For the polynomial  $x^2 + 7x + 10$ ,  $a = 1$ ,  $b = 7$ ,  $c = 10$ .

Sum of zeroes  $(\alpha + \beta) = \frac{-b}{a} = \frac{-7}{1} = -7$  & Product of zeroes  $(\alpha\beta) = \frac{c}{a} = \frac{10}{1} = 10$ .

$\frac{1}{\alpha} + \frac{1}{\beta} = \frac{(\beta + \alpha)}{(\alpha\beta)} = \frac{(\alpha + \beta)}{(\alpha\beta)} = \frac{-7}{10}$

7. Check whether -2 is a zero of the polynomial  $p(x) = x^3 + x^2 - 2x$ .

**Solution:** Given  $p(x) = x^3 + x^2 - 2x$ .

Substitute  $x = -2$ ,

$p(-2) = (-2)^3 + (-2)^2 - 2(-2) = 0$

Since  $p(-2) = 0$ , -2 is a zero of the polynomial.

8. If the sum of the zeroes of the quadratic polynomial  $kx^2 - 3x + 5$  is 1, find the value of k.

**Solution:** Let the polynomial be  $p(x) = kx^2 - 3x + 5$ . Here,  $a = k$ ,  $b = -3$ ,  $c = 5$ .

Sum of zeroes  $= \frac{-b}{a} = \frac{-(-3)}{k} = \frac{3}{k}$  & Given that the sum of zeroes is 1. So,  $\frac{3}{k} = 1 \Rightarrow k = 3$ .

9. If the product of the zeroes of the quadratic polynomial  $x^2 - 6x + k$  is 4, find the value of k.

**Solution:** Let the polynomial be  $p(x) = x^2 - 6x + k$ . Here,  $a = 1$ ,  $b = -6$ ,  $c = k$ .

Product of zeroes  $= \frac{c}{a} = \frac{k}{1} = k$ . Given that the product of zeroes is 4. So,  $k = 4$ .

**10:** Write the quadratic polynomial whose zeroes are 3 and -2.

**Solution:** Let the zeroes be  $\alpha = 3$  and  $\beta = -2$ .

Sum of zeroes  $(\alpha + \beta) = 3 + (-2) = 1$  & Product of zeroes  $(\alpha\beta) = 3 \times (-2) = -6$ .

A quadratic polynomial is given by  $k[x^2 - (\text{sum of zeroes})x + \text{product of zeroes}]$ .

$p(x) = k[x^2 - (1)x + (-6)] = k[x^2 - x - 6]$ , Choosing  $k=1$ ,  $p(x) = x^2 - x - 6$ .

### SHORT ANSWER TYPE QUESTIONS (3 MARKS QUESTIONS)

**1.** Find the zeroes of the polynomial  $4s^2 - 4s + 1$  and verify the relationship between the zeroes and the coefficients.

**Solution:** Let  $p(s) = 4s^2 - 4s + 1$ .

To find zeroes, set  $p(s) = 0$ , so, the zeroes are  $\alpha = \frac{1}{2}$  and  $\beta = \frac{1}{2}$ .

Verification:

For  $p(s) = 4s^2 - 4s + 1$ , we have  $a = 4$ ,  $b = -4$ ,  $c = 1$ .

Sum of zeroes  $(\alpha + \beta) = \frac{1}{2} + \frac{1}{2} = 1$ . & From coefficients,  $\frac{-b}{a} = \frac{-(-4)}{4} = \frac{4}{4} = 1$ . So,  $\alpha + \beta = \frac{-b}{a}$ .

Product of zeroes  $(\alpha\beta) = (\frac{1}{2}) \times (\frac{1}{2}) = \frac{1}{4}$ . & From coefficients,  $\frac{c}{a} = \frac{1}{4}$ . So,  $\alpha\beta = \frac{c}{a}$ .

Hence, the relationship is verified.

**2.** If  $\alpha$  and  $\beta$  are the zeroes of the quadratic polynomial  $p(x) = x^2 - 5x + 4$ , find the value of  $\alpha^2 + \beta^2$ .

**Solution:** For  $p(x) = x^2 - 5x + 4$ , we have  $a = 1$ ,  $b = -5$ ,  $c = 4$ .

Sum of zeroes  $(\alpha + \beta) = \frac{-b}{a} = \frac{-(-5)}{1} = 5$ . & Product of zeroes  $(\alpha\beta) = \frac{c}{a} = \frac{4}{1} = 4$ .

We know that  $(\alpha + \beta)^2 = \alpha^2 + \beta^2 + 2\alpha\beta$ .

So,  $\alpha^2 + \beta^2 = (\alpha + \beta)^2 - 2\alpha\beta = (5)^2 - 2(4) = 17$ .

**3.** Divide  $3x^3 + x^2 + 2x + 5$  by  $1 + 2x + x^2$ .

**Solution:** Dividend  $p(x) = 3x^3 + x^2 + 2x + 5$

Divisor  $g(x) = x^2 + 2x + 1$  (arranging in standard form)

Quotient  $q(x) = 3x - 5$

Remainder  $r(x) = 9x + 10$

**4.** Write quadratic polynomial whose zeroes are  $5\sqrt{3}$  and  $2\sqrt{5}$

**Solution:** Let the zeroes be  $\alpha = 5\sqrt{3}$  and  $\beta = 2\sqrt{5}$ .

$\alpha + \beta = 5\sqrt{3} + 2\sqrt{5}$ .  $\alpha\beta = (5\sqrt{3})(2\sqrt{5}) = 10\sqrt{15}$

Quadratic polynomial  $= x^2 - (5\sqrt{3} + 2\sqrt{5})x + 10\sqrt{15}$

**5.** Find the quadratic polynomial whose zeroes are  $(2 + \sqrt{3})$  and  $(2 - \sqrt{3})$ .

**Solution:** Let the zeroes be  $\alpha = 2 + \sqrt{3}$  and  $\beta = 2 - \sqrt{3}$ .

Sum of zeroes  $(\alpha + \beta) = (2 + \sqrt{3}) + (2 - \sqrt{3}) = 2 + 2 = 4$ .

Product of zeroes  $(\alpha\beta) = (2 + \sqrt{3})(2 - \sqrt{3}) = 2^2 - (\sqrt{3})^2 = 4 - 3 = 1$ .

The quadratic polynomial is  $k[x^2 - (\text{sum of zeroes})x + \text{product of zeroes}]$ .

$p(x) = k[x^2 - 4x + 1]$ . Choosing  $k=1$ ,  $p(x) = x^2 - 4x + 1$ .

**Answer:** The quadratic polynomial is  $x^2 - 4x + 1$ .

**6.** If  $(x + a)$  is a factor of the polynomial  $2x^2 + 2ax + 5x + 10$ , find the value of 'a'.

**Solution:** If  $(x + a)$  is a factor of  $p(x) = 2x^2 + 2ax + 5x + 10$ , then  $p(-a) = 0$ .

$2(-a)^2 + 2a(-a) + 5(-a) + 10 = 0 \Rightarrow a = 2$ .

**7.** If  $\alpha$  and  $\beta$  are the zeroes of the polynomial  $2y^2 + 7y + 5$ , find the value of  $(\alpha + 1)(\beta + 1)$ .

**Solution:** For the polynomial  $2y^2 + 7y + 5$ , we have  $a = 2$ ,  $b = 7$ ,  $c = 5$ .

Sum of zeroes  $(\alpha + \beta) = \frac{-b}{a} = \frac{-7}{2}$ . & Product of zeroes  $(\alpha\beta) = \frac{c}{a} = \frac{5}{2}$ .

$$(\alpha + 1)(\beta + 1) = \alpha\beta + \alpha + \beta + 1 = \alpha\beta + (\alpha + \beta) + 1 = \frac{5}{2} + \frac{-7}{2} + 1 = \frac{5-7}{2} + 1 = 0.$$

**8.** Find all the zeroes of the polynomial  $x^3 + 3x^2 - 2x - 6$ , if one of its zeroes is  $\sqrt{2}$ .

**Solution :** Let  $p(x) = x^3 + 3x^2 - 2x - 6$ .

We can factor  $p(x)$  by grouping:  $p(x) = x^2(x + 3) - 2(x + 3) = (x^2 - 2)(x + 3)$

To find the zeroes, set  $p(x) = 0 \Rightarrow (x^2 - 2)(x + 3) = 0$ .

The zeroes are  $\sqrt{2}$ ,  $-\sqrt{2}$ , and  $-3$ .

Given one zero is  $\sqrt{2}$ .

**9.** What must be subtracted from  $p(x) = x^3 - 6x^2 - 15x + 80$  so that the resulting polynomial is exactly divisible by  $g(x) = x^2 + x - 12$ ?

**Solution:** Divide  $p(x)$  by  $g(x)$  to find the remainder. The remainder is what must be subtracted.

After dividing we get the remainder is  $4x - 4$ .

So,  $4x - 4$  must be subtracted from  $p(x)$  for it to be exactly divisible by  $g(x)$ .

**10.** Form a quadratic polynomial one of whose zero is  $2 + \sqrt{5}$  and the sum of zeroes is 4.

**Solution:** Let the zeroes be  $\alpha$  and  $\beta$ .

Given one zero  $\alpha = 2 + \sqrt{5}$  & sum of zeroes  $(\alpha + \beta) = 4$ .

So,  $(2 + \sqrt{5}) + \beta = 4 \Rightarrow \beta = 2 - \sqrt{5}$ .

Now, find the product of zeroes  $(\alpha\beta)$ :

$$\alpha\beta = (2 + \sqrt{5})(2 - \sqrt{5}) = 2^2 - (\sqrt{5})^2 = 4 - 5 = -1.$$

The quadratic polynomial is  $k[x^2 - (\text{sum of zeroes})x + \text{product of zeroes}]$ .

$$p(x) = k[x^2 - (4)x + (-1)] = k[x^2 - 4x - 1].$$

Choosing  $k=1$ ,  $p(x) = x^2 - 4x - 1$ .

### LONG ANSWER TYPE QUESTIONS (5 MARK QUESTIONS)

**1.** Obtain all other zeroes of  $3x^4 + 6x^3 - 2x^2 - 10x - 5$ , if two of its zeroes are  $\sqrt{\frac{5}{3}}$  and  $-\sqrt{\frac{5}{3}}$

**Solution:** Given zeroes are  $\alpha = \sqrt{\frac{5}{3}}$  and  $\beta = -\sqrt{\frac{5}{3}}$ .

The factors are  $(x - \sqrt{\frac{5}{3}})$  and  $(x + \sqrt{\frac{5}{3}})$ .

Their product is  $(x - \sqrt{\frac{5}{3}})(x + \sqrt{\frac{5}{3}}) = x^2 - (\sqrt{\frac{5}{3}})^2 = x^2 - \frac{5}{3}$ .

So,  $(x^2 - \frac{5}{3})$  is a factor of the given polynomial.

We can write this as  $(\frac{1}{3})(3x^2 - 5)$ . So,  $(3x^2 - 5)$  is also a factor.

Divide  $3x^4 + 6x^3 - 2x^2 - 10x - 5$  by  $3x^2 - 5$ :

The quotient is  $x^2 + 2x + 1$ .

To find other zeroes, set the quotient to zero:

$$x^2 + 2x + 1 = 0 \Rightarrow x = -1$$

So, the other two zeroes are  $-1$  and  $-1$ .

**2.** Find the values of  $a$  and  $b$  so that  $x^4 + x^3 + 8x^2 + ax + b$  is divisible by  $x^2 + 1$ .

**Solution:** If  $x^4 + x^3 + 8x^2 + ax + b$  is divisible by  $x^2 + 1$ , the remainder must be zero.

Divide  $x^4 + x^3 + 8x^2 + ax + b$  by  $x^2 + 1$ :

The remainder is  $(a - 1)x + (b - 7)$

For exact divisibility, the remainder must be 0

So,  $(a - 1)x + (b - 7) = 0 \cdot x + 0$

Comparing coefficients:  $a = 1$  &  $b = 7$

**3.** What must be added to the polynomial  $p(x) = x^4 + 2x^3 - 2x^2 + x - 1$  so that the resulting polynomial is exactly divisible by  $x^2 + 2x - 3$ ?

**Solution:** Divide  $p(x)$  by  $x^2 + 2x - 3$  to find the remainder.

The remainder is  $-x + 2$ .

Let  $R(x)$  be what must be added.

$p(x) + R(x)$  should be divisible by  $x^2 + 2x - 3$ .

This means the remainder when  $p(x) + R(x)$  is divided by  $x^2 + 2x - 3$  is 0.

The remainder when  $p(x)$  is divided by  $x^2 + 2x - 3$  is  $(-x + 2)$ .

So, we must add  $-(-x + 2)$  to  $p(x)$ .

$-(-x + 2) = x - 2$ .

Therefore,  $x - 2$  must be added.

**4.** Verify the division algorithm for the polynomials  $p(x) = x^4 - 5x + 6$  and  $g(x) = 2 - x^2$ .

**Solution:**  $p(x) = x^4 - 5x + 6$

$g(x) = -x^2 + 2$  (writing in standard form)

Divide  $p(x)$  by  $g(x)$ : Quotient  $q(x) = -x^2 - 2$  & Remainder  $r(x) = -5x + 10$

Division Algorithm:  $p(x) = g(x) \times q(x) + r(x)$

RHS =  $(-x^2 + 2)(-x^2 - 2) + (-5x + 10)$

=  $[(-x^2)(-x^2 - 2) + 2(-x^2 - 2)] - 5x + 10 = x^4 - 5x + 6$

LHS =  $p(x) = x^4 - 5x + 6$

Since LHS = RHS, the division algorithm is verified.

**5.** If  $\alpha, \beta$  are the zeroes of the polynomial  $kx^2 + 4x + 4$  such that  $\alpha^2 + \beta^2 = 24$ , find the value of  $k$ .

**Solution:** For the polynomial  $kx^2 + 4x + 4$ :  $a = k$ ,  $b = 4$ ,  $c = 4$ .

Sum of zeroes  $(\alpha + \beta) = \frac{-b}{a} = \frac{-4}{k}$  & Product of zeroes  $(\alpha\beta) = \frac{c}{a} = \frac{4}{k}$ .

We know that  $\alpha^2 + \beta^2 = (\alpha + \beta)^2 - 2\alpha\beta$ .

Given  $\alpha^2 + \beta^2 = 24$ .

So,  $24 = \left(\frac{-4}{k}\right)^2 - 2\left(\frac{4}{k}\right)$

$24 = \frac{16}{k^2} - \frac{8}{k}$

$24k^2 = 16 - 8k$  [Multiply by  $k^2$  (assuming  $k \neq 0$ )]

$24k^2 + 8k - 16 = 0$

$(3k - 2)(k + 1) = 0$

So,  $3k - 2 = 0 \Rightarrow k = \frac{2}{3}$  (or),  $k + 1 = 0 \Rightarrow k = -1$ .

### **CASE BASED QUESTIONS**

**1.** Basketball and soccer are played with a spherical ball. Even though an athlete dribbles the ball in both sports, a basketball player uses his hands and a soccer player uses his feet. Usually, soccer is played outdoors on a large field and basketball is played indoor on a court made out of wood. The projectile (path traced) of soccer ball and basketball are in the form of parabola representing quadratic polynomial.



**Fig -1**

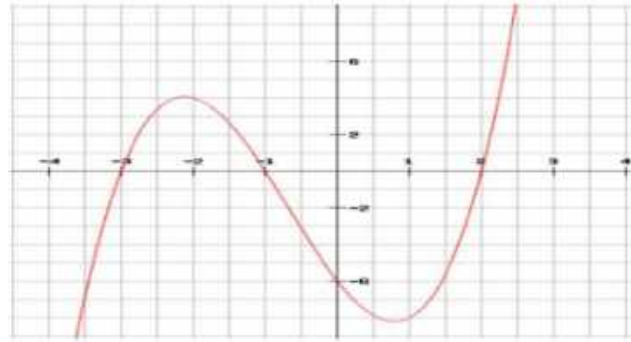

**Fig - 2**

(i) What is the shape of the path traced in Fig 1?

**Ans:** Parabola

(ii) When the parabola is downwards, then what you can say about value of 'a'?

**Ans :**  $a < 0$

(iii) In Fig 2 how many zeroes are there and what are they?

**Ans:** Three, -3, -1 and 2

2. Observe the position of athletic taking long jump. He used to follow a particular type of path. In the figure we can observe the path followed by an athlete.

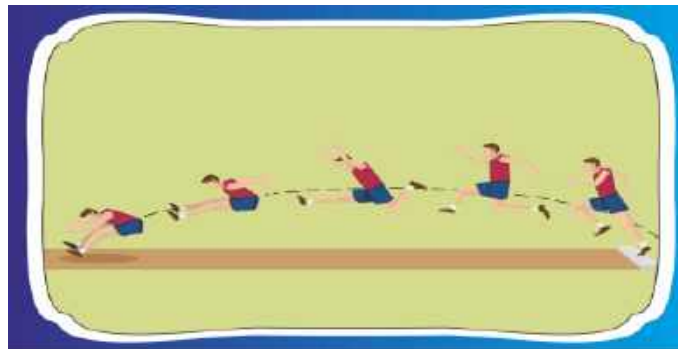

(i) What is the name of the path formed by different positions of the athlete.

**Ans :** Parabola

(ii) In the above case, if the quadratic polynomial is represented by  $ax^2 + bx + c$ , then what can you say about the value of 'a'?

**Ans :** As the parabola open downwards, the value of 'a' will be less than 0. ( $a < 0$ )

(iii) If the sum and product of the zeroes of the quadratic polynomial  $ax^2 + bx + c$  are equal. What is the relation between 'b' and 'c'?

**Ans:** Given polynomial is  $ax^2 + bx + c$ . Sum of the zeroes =  $-\frac{b}{a}$ , Product of the zeroes =  $\frac{c}{a}$

According to question,  $-\frac{b}{a} = \frac{c}{a} \Rightarrow -b = c \Rightarrow b + c = 0$

3. An asana is a body posture, originally and still a general term for a sitting meditation pose, and later extended in hatha yoga and modern yoga as exercise, to any type of pose or position, adding reclining, standing, inverted, twisting, and balancing poses. In the figure, one can observe that poses can be related to representation of quadratic polynomial.

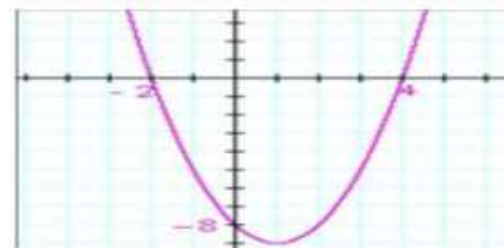

(i) What is the shape of figure shown?

**Ans :** Parabola

(ii) When the parabola is upwards, then what you can say about value of 'a'?

**Ans :**  $a > 0$

(iii) In the graph how many zeroes are there and what are they?

**Ans :** two zeroes, -2,4

### **HIGHER ORDER THINKING SKILL QUESTIONS**

1. If one zero of the polynomial  $p(x) = ax^2 + bx + c$  is twice the other, prove that  $2a\alpha^2 + b\alpha + c = 0$  and hence find a relation between a, b, and c.

**Solution:** Let one zero be  $\alpha$ , so the other is  $2\alpha$ .

$$\text{Sum of zeros} = \alpha + 2\alpha = 3\alpha = \frac{-b}{a} \Rightarrow \alpha = \frac{-b}{3a}$$

$$\text{Product} = \alpha \cdot 2\alpha = 2\alpha^2 = \frac{c}{a} \Rightarrow \alpha^2 = \frac{c}{2a}$$

$$\text{Now, } 2a\alpha^2 + b\alpha + c = 2a \cdot \left(\frac{c}{2a}\right) + b \cdot \left(\frac{-b}{3a}\right) + c = c - \frac{b^2}{3a} + c$$

$$\Rightarrow 2c - \frac{b^2}{3a} = 0 \Rightarrow 6ac = b^2$$

2. A quadratic polynomial has its zeros as reciprocals of each other. If its leading coefficient is 3, find the polynomial.

**Solution:** Let the zeros be  $\alpha$  and  $\frac{1}{\alpha}$

$$\text{Sum} = \alpha + \frac{1}{\alpha}, \text{ Product} = 1$$

$$\text{Polynomial: } 3x^2 - 3\left(\alpha + \frac{1}{\alpha}\right)x + 3$$

$$\text{Assuming } \alpha = 2 \Rightarrow \text{Sum} = 2.5 \Rightarrow \text{Polynomial: } 6x^2 - 15x + 6$$

3. A quadratic polynomial  $f(x)$  has the property that  $f(1) = f(-1)$ . Show that the coefficient of x must be zero.

**Solution:** Let  $f(x) = ax^2 + bx + c$

$$f(1) = a + b + c, f(-1) = a - b + c$$

$$f(1) = f(-1) \Rightarrow a + b + c = a - b + c \Rightarrow 2b = 0 \Rightarrow b = 0$$

4. Form a quadratic polynomial whose sum of the zeros is equal to their product and both zeros are rational numbers.

**Solution:** Let  $\alpha = \beta = r \Rightarrow \text{Sum} = 2r, \text{ Product} = r^2 \Rightarrow 2r = r^2 \Rightarrow r(r - 2) = 0 \Rightarrow r = 0 \text{ or } 2$

$$\text{If } r = 2 \Rightarrow \text{Polynomial: } (x - 2)^2 = x^2 - 4x + 4$$

5. A polynomial  $p(x)$  leaves the same remainder when divided by  $x - 1$  and  $x + 1$ . Show that the coefficient of the odd powers of x in  $p(x)$  is zero.

**Solution:**  $p(1) = p(-1)$

$$\text{Let } p(x) = a_0 + a_1x + a_2x^2 + \dots$$

$$p(1) = a_0 + a_1 + a_2 + \dots, p(-1) = a_0 - a_1 + a_2 - \dots$$

$$\text{If } p(1) = p(-1)$$

$$\Rightarrow 2a_1 + 2a_3 + \dots = 0$$

$$\Rightarrow a_1 = a_3 = \dots = 0$$

# CHAPTER-3

## PAIR OF LINEAR EQUATIONS IN TWO VARIABLES

### MIND MAPPING

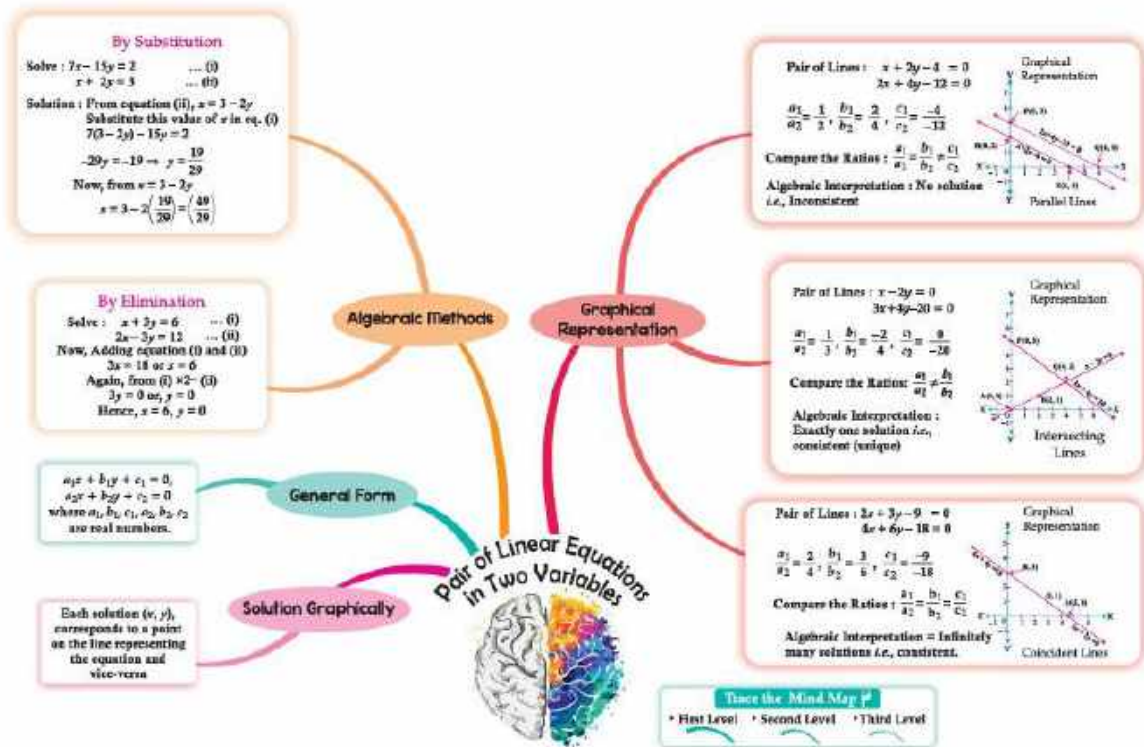

### Gist of the lesson:

1. Definition of the terms
2. Solving of linear equations in two variables --(a) Graphical Method (b) Algebraic Method
3. Algebraic Method- (a) Substitution (b) Elimination

### Definitions and Formulae:

1) Linear Equation in Two Variables- An equation which can be put in the form  $ax + by + c = 0$  where  $a, b, c$  are Real Numbers &  $a, b$  are not both zero, is called a Linear Equation in Two Variables  $x$  &  $y$ .  
Example:-  $2x + 5y - 6 = 0$

[ $a = 2, b = 5, c = -6$ ]

2) General Form for a Pair of Linear Equations in Two Variables  $x$  &  $y$ -

$$a_1x + b_1y + c_1 = 0 \quad [a_1, b_1, c_1 \text{ are Real Numbers \& } a_1, b_1 \text{ are not both zero}]$$

$$a_2x + b_2y + c_2 = 0 \quad [a_2, b_2, c_2 \text{ are Real Numbers \& } a_2, b_2 \text{ are not both zero}]$$

3) Method of Finding the Solution for a Pair of Linear Equations in Two Variables  $x$  &  $y$ -

i) Graphical Method

ii) Algebraic Method

a) Substitution Method

b) Elimination Method

4) Graphical Method

Plot the graph of the first equation and then graph of the second equation on the same rectangular coordinate system. The following three cases may arise.

Case 1 - If the lines intersect at a point, then the given system has a unique Solution given by the coordinates of the point of intersection.

Case 2 - If the lines are coincident, then the system is consistent and has infinitely many Solutions. In this case, every Solution of one of the equations is a Solution of the system.

Case 3 - If the lines are parallel, then the given system of equations is inconsistent i.e., it has no Solution.

### 5) Substitution Method

Step 1: Find the value of one variable, say  $y$  in terms of the other variable, i.e.,  $x$  from either equation, whichever is convenient.

Step 2: Substitute this value of  $y$  in the other equation, and reduce it to an equation in one variable, i.e., in terms of  $x$ , which can be solved.

Step 3: Substitute the value of  $x$  (or  $y$ ) obtained in Step 2 in the equation used in Step 1 to obtain the value of the other variable.

### 6) ELIMINATION METHOD

Step 1: First multiply both the equations by some suitable non-zero constants to make the coefficients of one variable (either  $x$  or  $y$ ) numerically equal.

Step 2: Then add or subtract one equation from the other so that one variable gets eliminated. If you get an equation in one variable, go to Step 3.

If in Step 2, we obtain a true statement involving no variable, then the original pair of equations has infinitely many Solutions.

If in Step 2, we obtain a false statement involving no variable, then the original pair of equations has no Solution, i.e., it is inconsistent.

Step 3: Solve the equation in one variable ( $x$  or  $y$ ) so obtained to get its value.

Step 4: Substitute this value of  $x$  (or  $y$ ) in either of the original equations to get the value of the other variable.

### MULTIPLE CHOICE QUESTIONS (1 MARK QUESTIONS).

**Q1.** The **Solution** of the equations  $x - y = 2$  and  $x + y = 4$  is:

- (a) 3 and 1                      (b) 4 and 3                      (c) 5 and 1                      (d) -1 and -3

**Solution:** The system of equations  $x - y = 2$  and  $x + y = 4$  is solved using elimination. Adding the equations gives  $2x = 6$ , so  $x = 3$ . Substituting into the second equation gives  $3 + y = 4$ , so  $y = 1$ .

The Solution is  $x = 3, y = 1$ .

**Ans:** (a) 3 and 1

**Q2.** If the lines  $3x + 2ky - 2 = 0$  and  $2x + 5y + 1 = 0$  are parallel, then what is the value of  $k$ ?

- (a)  $\frac{4}{15}$                       (b)  $\frac{15}{4}$                       (c)  $\frac{4}{5}$                       (d)  $\frac{5}{4}$

**Solution:** To make the lines  $3x + 2ky - 2 = 0$  and  $2x + 5y + 1 = 0$  parallel, we need  $\frac{3}{2} = \frac{2k}{5}$ .

Solving for  $k$  gives  $k = \frac{15}{4}$ . This value satisfies the parallel lines condition because  $\frac{2k}{5} \neq \frac{-2}{1}$ .

**Ans:** (b)  $\frac{15}{4}$

**Q3.** The pair of equations  $3x - 5y = 7$  and  $-6x + 10y = 7$  have

- (a) a unique Solution                      (b) infinitely many Solutions  
(c) no Solution                      (d) two Solutions

**Solution:**  $3x - 5y = 7$  and  $-6x + 10y = 7$  have  $\frac{a_1}{a_2} = \frac{b_1}{b_2} \neq \frac{c_1}{c_2}$ , thus, no Solution.

**Ans:** (c) no **Solution**

**Q4.** If a pair of linear equations is consistent, then the lines will be

- (a) always coincident                      (b) parallel  
(c) always intersecting                      (d) intersecting or coincident

**Solution:** Consistent linear equations have at least one **Solution**; lines can be intersecting or coincident. **Ans:** (d) intersecting or coincident

**Q5.** The pair of equations  $5x + 7y = 5$  and  $2x - 3y = 7$  are

- (a) consistent                      (b) inconsistent                      (c) coincident                      (d) none of these

**Solution:**  $5x + 7y = 5$  and  $2x - 3y = 7$  have  $\frac{a_1}{a_2} \neq \frac{b_1}{b_2}$ , so consistent

**Ans:** (a) consistent

**Q6.** Which of the following pair of equations are dependent?

- (a)  $2x + 3y = 9$  and  $4x + 6y = 18$                       (b)  $x + y = 2$  and  $2x - y = 4$   
(c)  $5x + y = 10$  and  $2x + y = 6$                       (d)  $x - y = 0$  and  $x + y = 4$

**Solution:** Dependent equations are those that represent the same line (coincident lines), meaning they have infinitely many Solutions. The condition is  $\frac{a_1}{a_2} = \frac{b_1}{b_2} = \frac{c_1}{c_2}$

Dependent equations are coincident lines.  $2x + 3y = 9$  and  $4x + 6y = 18$  have  $\frac{a_1}{a_2} = \frac{b_1}{b_2} = \frac{c_1}{c_2}$ , hence (a) is dependent.

**Ans:**(a)  $2x + 3y = 9$  and  $4x + 6y = 18$

Q7. The value of c for which the pair  $cx - y = 2$  and  $6x - 2y = 3$  will have infinitely many Solutions is:

- (a) 3                                      (b) -3                                      (c) -12                                      (d) No value

**Solution:** For infinitely many solutions, we need  $\frac{c}{6} = \frac{-1}{-2} = \frac{-2}{-3}$ , or  $\frac{c}{6} = \frac{1}{2} = \frac{2}{3}$ . Since  $\frac{1}{2} \neq \frac{2}{3}$ , no value of c satisfies the condition  $\frac{a_1}{a_2} = \frac{b_1}{b_2} = \frac{c_1}{c_2}$ , so, there is no value of c.

**Ans:** (d) No value

Q8. A fraction becomes  $\frac{1}{3}$  when 1 is subtracted from the numerator and it becomes  $\frac{1}{4}$  when 8 is added to the denominator. The fraction is:

- (a)  $\frac{3}{12}$                                       (b)  $\frac{4}{12}$                                       (c)  $\frac{5}{12}$                                       (d)  $\frac{7}{12}$

**Solution:** Let the fraction be represented as  $\frac{x}{y}$ . The problem provides two equations based on alterations to the numerator and denominator:  $\frac{x-1}{y} = \frac{1}{3}$  and  $\frac{x}{y+8} = \frac{1}{4}$ .

Solving this system of equations leads to  $x = 5$  and  $y = 12$ . Therefore, the original fraction is  $\frac{5}{12}$ .

**Ans:** (c)  $\frac{5}{12}$

Q9. The graph of equations  $x + 2y - 4 = 0$  and  $2x + 4y - 12 = 0$  represents:

- (a) intersecting lines    (b) parallel lines    (c) coincident lines    (d) none

**Solution:**  $x + 2y - 4 = 0$  and  $2x + 4y - 12 = 0$  have  $\frac{a_1}{a_2} = \frac{b_1}{b_2} \neq \frac{c_1}{c_2}$ , therefore (b) parallel lines.

**Ans:** (b) parallel lines

Q10. Which of the following is a condition for unique solution of a pair of linear equations?

- (a)  $\frac{a_1}{a_2} = \frac{b_1}{b_2}$                                       (b)  $\frac{a_1}{a_2} = \frac{b_1}{b_2} = \frac{c_1}{c_2}$ ,                                      (c)  $\frac{a_1}{a_2} \neq \frac{b_1}{b_2}$                                       (d)  $\frac{a_1}{a_2} = \frac{b_1}{b_2} \neq \frac{c_1}{c_2}$

**Solution:**

The condition for a unique **Solution** of linear equations is (c)  $\frac{a_1}{a_2} \neq \frac{b_1}{b_2}$ .

**Ans:** (c)

### **ASSERTION AND REASON QUESTIONS**

**Directions:** In the following questions, a statement of Assertion (A) is followed by a statement of Reason (R). Pick the correct option:

- (a) Both Assertion and Reason are true and Reason is the correct explanation of Assertion.  
(b) Both Assertion and Reason are true but Reason is NOT the correct explanation of Assertion.  
(c) Assertion is true but Reason is false.  
(d) Assertion is false but Reason is true.

1. **Assertion (A):** A pair of linear equations has no **Solution** if it is represented by intersecting lines.

**Reason (R):** Intersecting lines represent a pair of equations having a unique **Solution**.

**Ans:** (d)

2. **Assertion (A):** If the pair of equations has the same **Solution**, then it is called consistent.

**Reason (R):** Consistent system has at least one **Solution**.

**Ans:** (a)

3. **Assertion (A):** The pair of equations  $2x + 3y = 6$  and  $4x + 6y = 10$  are consistent.

**Reason (R):** They represent parallel lines.

**Ans:** (d)

**4.Assertion (A):** The graph of a pair of linear equations is a pair of parallel lines if there is no solution.

**Reason (R):** Parallel lines never intersect and hence are inconsistent.

**Ans:** (a)

**5.Assertion (A):** If  $\frac{a_1}{a_2} = \frac{b_1}{b_2} \neq \frac{c_1}{c_2}$ , the system is inconsistent.

**Reason (R):** Such a system represents parallel lines.

**Ans:** (a)

**6.Assertion (A):** The equations  $x + 2y = 3$  and  $2x + 4y = 6$  represent intersecting lines.

**Reason (R):** Their slopes are same.

**Ans:** (d)

**7.Assertion (A):** The pair  $2x + 3y = 8$  and  $4x + 6y = 10$  has a unique solution.

**Reason (R):** Lines with different slopes intersect at one point.

**Ans:** (d)

**8.Assertion (A):** The system of equations  $x + y = 5$  and  $2x + 2y = 10$  has infinitely many solutions.

**Reason (R):** Both equations represent the same line.

**Ans:** (a)

**9.Assertion (A):** If the graphical representation of a system of equations results in two parallel lines, the system is inconsistent.

**Reason (R):** In an inconsistent system, there is no point common to both lines.

**Ans:** (a)

**10.Assertion (A):** A system of equations with infinitely many **Solutions** must be inconsistent.

**Reason (R):** Coincident lines have no unique solution.

**Ans:** (d)

### **VERY SHORT ANSWER TYPE QUESTIONS (2 MARKS QUESTIONS)**

1. Solve the pair of linear equations:  $3x - y = 3$  and  $9x - 3y = 9$

**Solution:** The equation  $9x - 3y = 9$  is simply a multiple of  $3x - y = 3$ . They represent the same line on a graph, thus the system has infinitely many Solutions because every point on the line is a Solution.

2. Solve the following pair of equations:  $s + t = 15$ ,  $2s - 3t = 5$

**Solution:** Using substitution on the system  $s + t = 15$  and  $2s - 3t = 5$ , we isolate 's' in the first equation ( $s = 15 - t$ ) and substitute it into the second. Solving the resulting equation for 't' yields  $t = 5$ .

Plugging  $t = 5$  back into  $s = 15 - t$  gives  $s = 10$ . Therefore, the Solution is  $s = 10$  and  $t = 5$ .

3. Find the value of k so that the pair  $x + 2y = 5$  and  $3x + ky + 15 = 0$  has a unique solution.

**Solution:** For linear equations to have a unique solution,  $\frac{a_1}{a_2} \neq \frac{b_1}{b_2}$ . Applying this to  $x + 2y = 5$  and  $3x + ky + 15 = 0$  requires that  $\frac{1}{3} \neq \frac{2}{k}$ .

Solving this inequality shows that k cannot be equal to 6 for a unique solution to exist.  $k \neq 6$

4. Find whether the equations are consistent or inconsistent:  $5x + 7y = 5$ ,  $2x - 3y = 7$

**Solution:** The system  $5x + 7y = 5$  and  $2x - 3y = 7$  has)  $\frac{a_1}{a_2} \neq \frac{b_1}{b_2}$ , so the lines must intersect in one point and have exactly one **Solution**, meaning it is consistent with a unique **Solution**.

Consistent (unique **Solution**)

5. Half the perimeter of a rectangular garden is 36 m. If the length is 4 m more than the width, form the pair of equations.

**Solution:** We represent length and width of a rectangular garden as 'x' and 'y' respectively. Half the perimeter is 'x + y', which equals 36. Also, the length (x) is 4 more than the width (y), which translates into the expression  $x = y + 4$ . Thus the equations are,  $x + y = 36$ ,  $x = y + 4$ .

6. Determine graphically the solution of:

$x + y = 6$ ,  $x - y = 2$

**Solution:**  $x = 4$ ,  $y = 2$  (The graphical solution would be the graph showing the intersection at (4,2)).

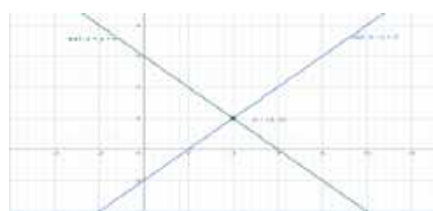

Q7. Solve:  $x + 2y - 4 = 0$ ,  $2x + 4y - 12 = 0$

**Solution:** The equations  $x + 2y - 4 = 0$  and  $2x + 4y - 12 = 0$  have proportional x and y coefficients ( $\frac{a_1}{a_2} = \frac{b_1}{b_2}$ ), but different constant ratios ( $\frac{c_1}{c_2}$ ). Since  $\frac{a_1}{a_2} = \frac{b_1}{b_2} \neq \frac{c_1}{c_2}$ , they represent parallel lines that never intersect. Therefore, the system has no **Solution** and is considered inconsistent.

Q8. Represent the following situation algebraically:

“The cost of 2 kg apples and 1 kg grapes is Rs.160. The cost of 4 kg apples and 2 kg grapes is Rs300.”

**Solution:**  $2x + y = 160$ ,  $4x + 2y = 300$  (Cost Problem): Letting 'x' be the cost of 1 kg of apples and 'y' be the cost of 1 kg of grapes, the provided information directly translates into the linear equations:  $2x + y = 160$  and  $4x + 2y = 300$ .

9. Check if the equations are dependent:  $2x + 3y = 9$  and  $4x + 6y = 18$

**Solution:** The equation  $4x + 6y = 18$  is just double the equation  $2x + 3y = 9$ . These two equations represent the same line, therefore the equations are dependent and have infinitely many solutions.

10. A number consists of two digits. The digit at the tens place is 3 more than the unit's digit. The sum of the digits is 9. Find the number.

**Solution:** Let 'x' be the units digit and 'y' be the tens digit. The digits relationship forms two equations:

$$y = x + 3 \text{ and } x + y = 9.$$

Solving these simultaneously gives  $x = 3$  and  $y = 6$ , so the number is  $10(y) + x = 10(6) + 3 = 63$ .

### **SHORT ANSWER TYPE QUESTIONS (3 MARKS QUESTIONS)**

1. Find the value of k for which the system:  $x + 2y = 5$ ,  $3x + ky + 15 = 0$  has a unique solution.

**Solution:** For  $x + 2y = 5$ ,  $3x + ky + 15 = 0$  to have a unique Solution,  $\frac{a_1}{a_2} \neq \frac{b_1}{b_2}$ . This translates to  $\frac{1}{3} \neq \frac{2}{k}$ .

Solving for k gives  $k \neq 6$

2. A fraction becomes  $\frac{5}{7}$  if 2 is added to both numerator and denominator. If 1 is subtracted from both, it becomes  $\frac{1}{2}$ . Find the fraction.

**Solution:** Let the fraction be  $\frac{x}{y}$ . We have  $\frac{(x+2)}{(y+2)} = \frac{5}{7}$  and  $\frac{(x-1)}{(y-1)} = \frac{1}{2}$ .

Solving the equations  $7x - 5y = -4$  and  $2x - y = 1$  gives  $x = 3$  and  $y = 5$ . The fraction is  $\frac{3}{5}$

3. Solve the pair:  $49x + 51y = 499$ ,  $51x + 49y = 501$

**Solution:** Adding and subtracting the equations  $49x + 51y = 499$  and  $51x + 49y = 501$

yields  $x + y = 10$  and  $-x + y = -1$ . Solving gives  $x = \frac{11}{2}$ ,  $y = \frac{9}{2}$ .

4. Graphically solve the pair:  $x + 2y = 4$ ,  $2x + 4y = 12$

**Solution:** Graphing  $x + 2y = 4$  and  $2x + 4y = 12$  shows parallel lines, as they have the same slope.

Since they don't intersect, there is no solution.

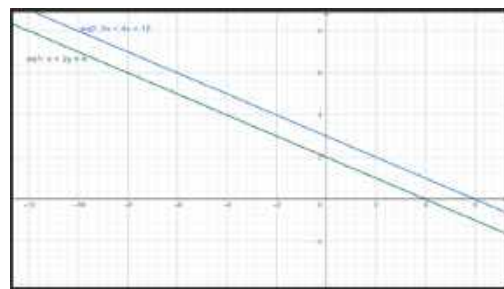

5. Three years hence, a father's age will be three times that of his son. Five years ago, the father was seven times the son's age. Find their present ages.

**Solution:** Let father's age be 'x' and son's 'y'.

Three years hence:  $x + 3 = 3(y + 3)$ .

Five years ago:  $x - 5 = 7(y - 5)$ .

Solving  $x - 3y = 6$  and  $x - 7y = -30$  gives  $y = 9$  and  $x = 33$ .

∴ Father's present age = 33 years, Son's present age = 9 years.

6. Solve by substitution method:  $7x - 15y = 2$ ,  $x + 2y = 3$

**Solution:** Solving for  $x=3-2y$  in the second equation and using in the first equation you get:  $x = \frac{49}{29}$ ,  $y = \frac{19}{29}$

$\therefore x = \frac{49}{29}$ ,  $y = \frac{19}{29}$  is the solution

7. Solve the pair:  $x + y = 6$ ,  $x - y = 4$

**Solution:** Adding  $x + y = 6$  and  $x - y = 4$  yields  $2x = 10$ , so  $x = 5$ . Substituting into  $x + y = 6$ , we get  $y = 1$ .

$\therefore x = 5$ ,  $y = 1$  is the solution

8. The cost of 2 pencils and 3 pens is Rs11. The cost of 1 pencil and 2 pens is Rs7. Find the cost of each item.

**Solution:** Let pencil cost Rs  $x$  and pen Rs  $y$ . The system is  $2x + 3y = 11$ ,  $x + 2y = 7$ .

Solving by elimination/substitution yields  $x = 1$  and  $y = 3$ .

$\therefore$  Cost of one pencil = Rs 1, Cost of one pen = Rs 3.

9. Form the pair of equations: "The sum of two numbers is 25. One number is 3 less than double the other."

**Solution:** "The sum of two numbers is 25," so  $x + y = 25$ .

"One number is 3 less than double the other" gives  $x = 2y - 3$  or  $x - 2y = -3$ .

10. Solve the following pair using substitution:  $3x + 2y = 16$ ,  $x = y + 2$

**Solution:** Given  $3x + 2y = 16$ ,  $x = y + 2$ , substitute the second equation into the first.

This gives  $3(y+2) + 2y = 16$ , so  $5y = 10$ . Therefore,  $y = 2$  and  $x = 4$ .

### LONG ANSWER TYPE QUESTIONS (5 MARKS QUESTIONS)

1. On reversing the digits of a two-digit number, the number obtained is 9 less than three times the original number. If the difference between the numbers is 45, find the original number.

**Solution:** Units digit =  $x$ , Tens digit =  $y$ . Original:  $10y + x$ . Reversed:  $10x + y$ .

Condition 1:  $10x + y = 3(10y + x) - 9 \Rightarrow 7x - 29y = -9$  (Eq. 1)

Condition 2:  $|(10y + x) - (10x + y)| = 45$ .

Case 1:  $10x + y - (10y + x) = 45 \Rightarrow 9x - 9y = 45 \Rightarrow x - y = 5$  (Eq. 2a)

Case 2:  $10y + x - (10x + y) = 45 \Rightarrow 9y - 9x = 45 \Rightarrow y - x = 5$  (Eq. 2b)

Using Eq. 2a:  $x = y + 5$ . Substitute into Eq. 1:  $7(y + 5) - 29y = -9 \Rightarrow -22y = 44 \Rightarrow y = 2$ .

$x = 2 + 5 = 7$ .

$\therefore$  Original number =  $10(2) + 7 = 27$ .

2. A shopkeeper buys 2 pencils and 3 pens for Rs.11. Sumeet buys 1 pencil and 2 pens for Rs.7. Find the cost of 1 pencil and 1 pen.

**Solution:** Pencil cost =  $x$ , Pen cost =  $y$ . Condition 1:  $2x + 3y = 11$  (Eq. 1)

Condition 2:  $x + 2y = 7$  (Eq. 2) Multiply Eq. 2 by 2:  $2x + 4y = 14$  (Eq. 3)

Eq. 3 - Eq. 1:  $y = 3$ . Substitute  $y = 3$  into Eq. 2:  $x + 2(3) = 7 \Rightarrow x = 1$ .

$\therefore$  Pencil = Rs1, Pen = Rs 3. Cost of 1 pencil and 1 pen = Rs 4.

3. A boat takes 2 hours to travel 20 km downstream and 4 hours to travel the same distance upstream. Find the speed of boat and speed of stream.

**Solution:** Boat speed =  $x$ , Stream speed =  $y$ . Downstream:  $20 = (x + y) 2 \Rightarrow x + y = 10$  (Eq. 1).

Upstream:  $20 = (x - y) 4 \Rightarrow x - y = 5$  (Eq. 2)

Eq. 1 + Eq. 2:  $2x = 15 \Rightarrow x = 7.5$ ,

Substitute  $x = 7.5$  into Eq. 1:  $7.5 + y = 10 \Rightarrow y = 2.5$ .

$\therefore$  Boat speed = 7.5 km/h, Stream speed = 2.5 km/h

4. Solve the pair:  $2x + 3y = 12$ ,  $x - y = 1$

**Solution:** Eq. 1:  $2x + 3y = 12$ , Eq. 2:  $x - y = 1 \Rightarrow x = y + 1$

Substitute  $x = y + 1$  into Eq. 1:  $2(y + 1) + 3y = 12 \Rightarrow 5y + 2 = 12 \Rightarrow 5y = 10 \Rightarrow y = 2$

$x = 2 + 1 = 3$ .

$x = 3$ ,  $y = 2$  is the solution.

5. The sum of the digits of a two-digit number is 9. If 27 is subtracted from the number, the digits interchange their places. Find the number.

**Solution:** Tens digit =  $x$ , Units digit =  $y$ . original number:  $10x + y$ .

Condition 1:  $x + y = 9$  (Eq.1), Condition 2:  $(10x + y) - 27 = 10y + x \Rightarrow 9x - 9y = 27 \Rightarrow x - y = 3$  (Eq.2),

Eq. 1 + Eq. 2:  $2x = 12 \Rightarrow x = 6$ , Substitute  $x = 6$  into Eq. 1:  $6 + y = 9 \Rightarrow y = 3$

$\therefore$  Original number:  $10(6) + 3 = 63$

6. Solve graphically:  $x + y = 4$ ,  $x - y = 2$

**Solution:**  $x = 3$ ,  $y = 1$ .

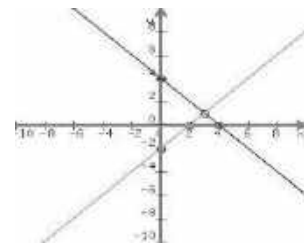

The graph would show two lines intersecting at the point  $(3, 1)$ .

7. The cost of 4 oranges and 3 mangoes is Rs.30. The cost of 2 oranges and 4 mangoes is Rs 28. Find cost of one orange and one mango.

**Solution:** Orange cost =  $x$ , Mango cost =  $y$ .

Condition 1:  $4x + 3y = 30$  (Eq. 1), Condition 2:  $2x + 4y = 28$  (Eq. 2)

Multiply Eq. 2 by 2:  $4x + 8y = 56$  (Eq. 3), Eq. 3 - Eq. 1:  $5y = 26 \Rightarrow y = 5.2$

Substitute  $y = 5.2$  into Eq. 2:  $2x + 4(5.2) = 28 \Rightarrow 2x + 20.8 = 28 \Rightarrow 2x = 7.2 \Rightarrow x = 3.6$

$\therefore$  Orange cost = Rs 3.60, Mango cost = Rs 5.20

Q8. Solve:  $\frac{1}{x} + \frac{1}{y} = 5$ ,  $\frac{1}{x} - \frac{1}{y} = 1$

**Solution:**  $a = \frac{1}{x}$ ,  $b = \frac{1}{y}$ , Eq. 1:  $a + b = 5$ , Eq. 2:  $a - b = 1$ , Add equations:  $2a = 6 \Rightarrow a = 3$

Substitute into Eq. 1:  $3 + b = 5 \Rightarrow b = 2$ ,  $a = 3 \Rightarrow x = \frac{1}{3}$ ,  $b = 2 \Rightarrow y = \frac{1}{2}$

9. A father is three times as old as his son. After 5 years, he will be twice as old. Find their ages.

**Solution:** Son's age =  $x$ , Father's age =  $3x$ , After 5 years: Son:  $x + 5$ , Father:  $3x + 5$

$3x + 5 = 2(x + 5) \Rightarrow 3x + 5 = 2x + 10 \Rightarrow x = 5$ ,

$\therefore$  Son's age = 5 yrs, Father's age =  $3(5) = 15$  yrs

10. Represent graphically and solve:  $x + y = 10$ ,  $x - y = 2$

**Solution:** Eq. 1:  $x + y = 10$ , Eq. 2:  $x - y = 2$ , Add equations:  $2x = 12 \Rightarrow x = 6$

Substitute into Eq. 1:  $6 + y = 10 \Rightarrow y = 4$

$\therefore x = 6$ ,  $y = 4$ . (Graphically, lines intersect at  $(6, 4)$ ).

### CASE BASED QUESTIONS (04 MARKS QUESTIONS)

1. Mr. Manoj Jindal arranged a lunch party. The expenses are partly fixed and partly proportional to the number of guests. The total cost for 7 guests is Rs650 and for 11 guests is Rs 970.

(i) Form a pair of linear equations.

(ii) Find the fixed and variable expenses.

(iii) How much will it cost for 15 guests?

(iv) If Mr. Jindal has a budget of Rs1500, what is the maximum number of guests he can invite?

**Solution:** (i)  $x + 7y = 650$  (Eq. 1),  $x + 11y = 970$  (Eq. 2)

(ii) Eq. 2 - Eq. 1:  $4y = 320 \Rightarrow y = 80$ .  $x + 7(80) = 650 \Rightarrow x = 90$ .

Fixed = Rs90, Variable = Rs80

(iii) Cost for 15 =  $90 + 15(80) = \text{Rs}1290$

(iv) Let 'n' be maximum guests.  $90 + n(80) = 1500 \Rightarrow 80n = 1410 \Rightarrow n = 17.625$ . Thus  $n=17$ .

2. From Bangalore bus stand, 2 tickets to Malleshwaram and 3 to Yeshwanthpur cost Rs46; 3 to Malleshwaram and 5 to Yeshwanthpur cost Rs74.

(i) Form a pair of linear equations

(ii) Find fare to each place

(iii) Cost of 4 tickets to Malleshwaram and 2 to Yeshwanthpur?

(iv) A tourist has Rs100. How many tickets to Malleshwaram can they buy if they also need one ticket to Yeshwanthpur?

**Solution:** (i)  $2x + 3y = 46$  (Eq. 1),  $3x + 5y = 74$  (Eq. 2)

(ii)  $6x + 9y = 138$ ,  $6x + 10y = 148$ . Subtract  $\Rightarrow y = 10$ .  $2x + 3(10) = 46$



$\Rightarrow x = 8$ . Mallechwaram = Rs8, Yeshwanthpur = Rs10

(iii)  $4(8) + 2(10) = \text{Rs } 52$

(iv) Spend Rs10 on Yeshwanthpur. Remaining: Rs 90. Each Mallechwaram ticket is  $\frac{90}{8} = 11.25$ . So, 11 tickets.

3. A chemist has two solutions: one containing 30% alcohol and another 70%. How much of each must he mix to get 40 L of 40% solution?

(i) Form equations

(ii) Solve for the quantities of each solution.

(iii) If the chemist needs to create 20 L of 50% solution instead, how much of each would he need?

**Solution:** (i)  $x + y = 40$  (Eq. 1),  $0.3x + 0.7y = 0.4(40) = 16$  (Eq. 2)

(ii) From Eq 1:  $x = 40 - y$ . Substitute:  $0.3(40 - y) + 0.7y = 16$

$\Rightarrow 12 - 0.3y + 0.7y = 16 \Rightarrow 0.4y = 4 \Rightarrow y = 10$ .  $x = 40 - 10 = 30$ ,

30% solution = 30 L and 70% solution = 10 L

For 40 L of 40% solution, the chemist needs 30L of 30% solution and 10L of 70% solution.

(iii)  $x + y = 20$ ,  $0.3x + 0.7y = 0.5(20) = 10$ .  $x = 20 - y$ .  $0.3(20 - y) + 0.7y = 10 \Rightarrow 6 - 0.3y + 0.7y = 10$

$\Rightarrow 0.4y = 4 \Rightarrow y = 10$ .  $x = 20 - 10 = 10$ , 30% solution = 10 L, 70% solution = 10 L

For 20 L of 50% solution, the chemist needs 10L of 30% solution and 10L of 70% solution.



### HIGHER ORDER THINKING SKILLS

1. Solve:  $\frac{1}{x+y} + \frac{1}{x-y} = \frac{5}{6}$ ,  $\frac{1}{x+y} - \frac{1}{x-y} = \frac{1}{6}$

**Solution:**  $a = \frac{1}{x+y}$ ,  $b = \frac{1}{x-y}$ ,  $a + b = \frac{5}{6}$ ,  $a - b = \frac{1}{6}$ ,  $\Rightarrow 2a = 1 \Rightarrow a = \frac{1}{2}$ .  $\frac{1}{2} + b = \frac{5}{6} \Rightarrow b = \frac{1}{3}$ .

$x + y = 2$ ,  $x - y = 3$ .  $2x = 5 \Rightarrow x = \frac{5}{2}$ .  $y = 2 - \frac{5}{2} = \frac{-1}{2}$ .

$\therefore x = \frac{5}{2}$ ,  $y = \frac{-1}{2}$

2. A sum of Rs 500 is in denominations of Rs 5 and Rs 10 notes. If the total number of notes is 90, find how many of each type.

**Solution:** Rs 5 notes =  $x$ , Rs 10 notes =  $y$ .  $x + y = 90$ ,  $5x + 10y = 500$ .  $\Rightarrow x + 2y = 100$ . Subtracting:  $y = 10$ .  $x = 90 - 10 = 80$ .

$\therefore$  Rs5 notes = 80, Rs10 notes = 10

3. The sum of the ages of father and son is 45. Five years ago, the father's age was 4 times his son's. Find their present ages.

**Solution:** Father =  $x$ , Son =  $y$ .  $x + y = 45$ .  $x - 5 = 4(y - 5) \Rightarrow x - 4y = -15$ .

Substitute  $x = 45 - y$ :  $45 - y - 4y = -15 \Rightarrow -5y = -60 \Rightarrow y = 12$ .  $x = 45 - 12 = 33$ .

$\therefore$  Father = 33 years, Son = 12 years

4. Solve:  $\frac{3x}{2y} + \frac{2y}{3x} = \frac{13}{6}$ ,  $\frac{3x}{2y} - \frac{2y}{3x} = \frac{1}{6}$

**Solution:**  $a = \frac{3x}{2y}$ ,  $b = \frac{2y}{3x}$ .  $a + b = \frac{13}{6}$ ,  $a - b = \frac{1}{6}$ .  $2a = \frac{14}{6} \Rightarrow a = \frac{7}{6}$ .  $b = 1$ . inconsistent because  $a$  &  $b$  must be reciprocal. Therefore, no unique solutions.

$\therefore$  The original equations are inconsistent, therefore not solvable.

5. If 6 is subtracted from the numerator and 3 from the denominator of a fraction, it becomes  $\frac{1}{2}$ . If 3 is added to both, it becomes  $\frac{4}{5}$ . Find the fraction.

**Solution:** Fraction =  $\frac{x}{y}$ .  $\frac{x-6}{y-3} = \frac{1}{2} \Rightarrow 2x - 12 = y - 3 \Rightarrow 2x - y = 9$ .

$\frac{x+3}{y+3} = \frac{4}{5} \Rightarrow 5x + 15 = 4y + 12 \Rightarrow 5x - 4y = -3$ .  $y = 2x - 9$ . Substitute:  $5x - 4(2x - 9) = -3 \Rightarrow 5x - 8x + 36 = -3 \Rightarrow -3x = -39 \Rightarrow x = 13$ .  $y = 2(13) - 9 = 17$ .

$\therefore \frac{13}{17}$  is the required fraction.

# CHAPTER-4

## QUADRATIC EQUATIONS

### MIND MAPPING

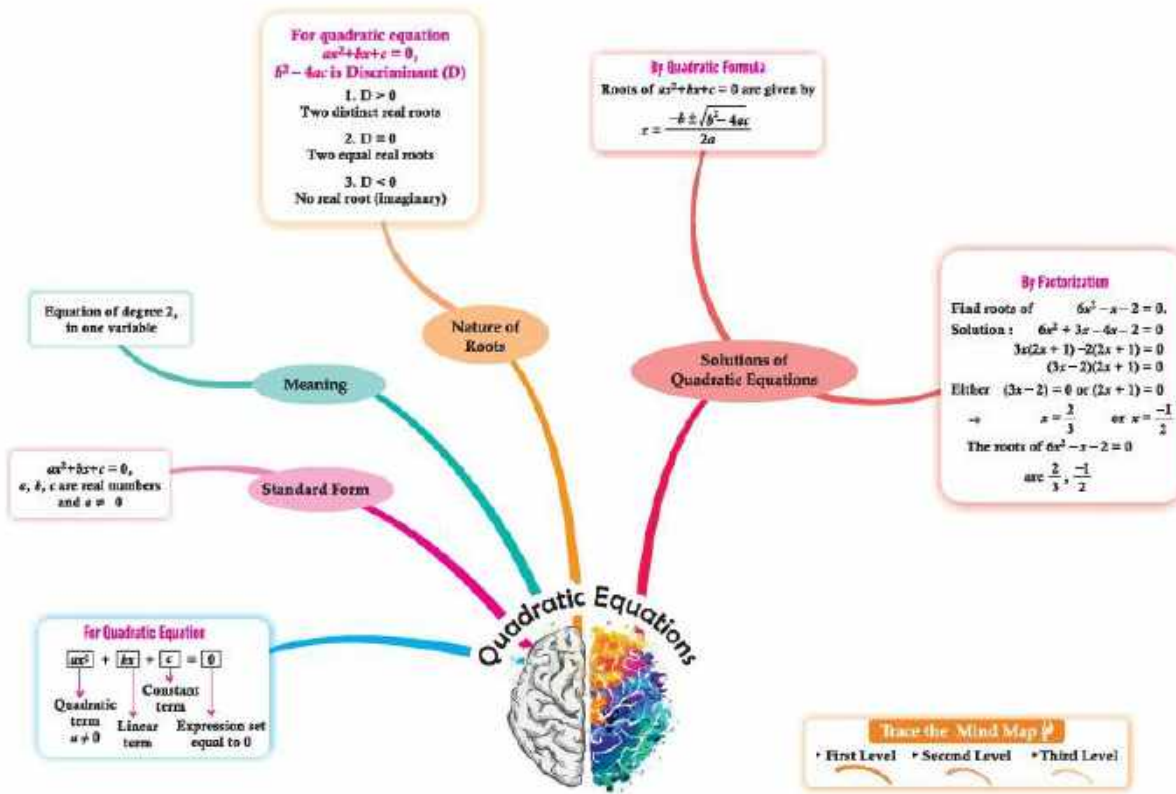

### GIST/SUMMARY OF THE CHAPTER

- Introduction
- Quadratic Equations: Standard form of a Quadratic Equation
- Solution of a Quadratic Equation by Factorisation Method, Quadratic Formula Method
- Nature of Roots

### DEFINITIONS

#### QUADRATIC EQUATION

A quadratic equation in the variable  $x$  is of the form  $ax^2 + bx + c = 0$ , where  $a, b, c$  are real numbers and  $a \neq 0$ .

The degree of a quadratic equation  $ax^2 + bx + c = 0$  is 2,

#### STANDARD FORM:

The standard form (general form) of a quadratic equation is  $ax^2 + bx + c = 0$ , where  $a, b$  and  $c$  are real numbers and  $a \neq 0$ .

#### ROOTS:

A real number  $\alpha$  is said to be a root of the quadratic equation  $ax^2 + bx + c = 0$ , if  $a\alpha^2 + b\alpha + c = 0$ . (The zeroes of the quadratic polynomial  $ax^2 + bx + c$  and the roots of the quadratic equation  $ax^2 + bx + c = 0$  are the same)

The values of  $x$  that satisfy the quadratic equation, also called solutions.

#### METHODS OF SOLVING:

**1. Factorization Method:** Breaking down the quadratic equation into two linear factors.

**2. Quadratic Formula:** A direct formula for finding the roots.

$$x = \frac{-b \pm \sqrt{b^2 - 4ac}}{2a}, \quad b^2 - 4ac \geq 0$$

## NATURE OF THE ROOTS:

### DISCRIMINANT (D):

The expression  $b^2 - 4ac$ , which determines the nature of the roots (distinct real roots, equal real roots, or complex roots).

- If  $D = b^2 - 4ac > 0$ : Two distinct real roots.
- If  $D = b^2 - 4ac = 0$ : Two equal real roots (repeated roots).
- If  $D = b^2 - 4ac < 0$ : No real roots.

### Applications:

- Quadratic equations are used in various fields like Physics, Engineering, and Economics to model different scenarios.
- They can be used to solve problems involving Geometry, Projectile motion, and Optimization.

### Method to Solve Word Problems:

Step-1 Firstly, Consider the first quantity as a variable (say  $x$ ) and then find the other quantities in terms of  $x$  by using the given condition.

Step-2 According to the given condition, write the equation in the quantities which is obtained from step-1.

Step-3 Simplify the equation obtained in step-2 to get quadratic equation.

Step-4 Now, simplify the quadratic equation by any one of the methods (i.e. factorization and quadratic formula) to obtain the value(s) of variable  $x$ .

Step-5 Further check whether the value(s) of variable  $x$ , satisfies the given condition or not.

Step-6 Find the values of the quantities. Also, Find the values of other information, if asked in the question.

## FORMULAE

### 1. Solution of Quadratic Equation by Quadratic Formula

$$X = \frac{-b \pm \sqrt{(b^2 - 4ac)}}{2a} \quad \text{or} \quad X = \frac{-b \pm \sqrt{D}}{2a} \quad \text{where } D = b^2 - 4ac \text{ is known as Discriminant}$$

This Formula is known as **Quadratic formula or Sridharacharya Formula**

2. Condition for two equal real roots  $D=0$  i.e.  $b^2 - 4ac = 0$ .

$$\text{If } D = b^2 - 4ac = 0 \text{ then } x = \frac{-b}{2a}, x = \frac{-b}{2a}$$

3. Condition for two distinct real roots  $D > 0$  i.e.  $b^2 - 4ac > 0$

If  $D = b^2 - 4ac > 0$  then

$$X = \frac{-b + \sqrt{D}}{2a}, X = \frac{-b - \sqrt{D}}{2a}$$

4. Condition for no real roots  $D < 0$  i.e.  $b^2 - 4ac < 0$

If  $D = b^2 - 4ac < 0$   $\sqrt{D}$  can not be evaluated as there is no real roots.

### **MULTIPLE CHOICE QUESTIONS (1 MARK QUESTIONS)**

1. If the quadratic equation  $3x + \frac{1}{x} = x + 3$  is written in standard form, then

(a)  $a=3, b=3, c=1$

(b)  $a=3, b=-3, c=1$

(c)  $a=2, b=-3, c=1$

(d)  $a=3, b=-3, c=3$

**Ans.** (c)  $a=2, b=-3, c=1$

$$3x + \frac{1}{x} = x + 3, \text{ Multiplying throughout the equation by } x$$

$$3x^2 + 1 = x^2 + 3x \Rightarrow 2x^2 - 3x + 1$$

2. For the equation  $x^2 + 5x - 1$ , which of the following statements is correct?

(a) The roots of the equation are equal  
negative

(b) The discriminant of the equation is

(c) The roots of the equation are real, distinct and irrational (d) The discriminant is equal to zero

**Ans.** (c) The roots of the equation are real, distinct and irrational

$$b^2 - 4ac = 5^2 - 4(1)(-1)$$

$$25 + 4 = 29 \text{ which is greater than } 0 \text{ and irrational.}$$

3. If the roots of the equation  $ax^2 + bx + c$  are real and equal, what will be the relation between a, b, c?

- (a)  $b^2 = 4ac$                       (b)  $b^2 = ac$                       (c)  $b^2 = 2ac$                       (d)  $b^2 = \sqrt{ac}$

**Ans.** (a)  $b^2 = 4ac$

4. If  $\frac{1}{2}$  is a root of the quadratic equation  $x^2 - mx - \frac{5}{4} = 0$ , then value of m is:

- (a) 2                                      (b) -2                                      (c) -3                                      (d) 3

**Ans.** (b) -2, Given  $x = \frac{1}{2}$  as root of equation  $x^2 - mx - \frac{5}{4} = 0$ .

$$\left(\frac{1}{2}\right)^2 - m\left(\frac{1}{2}\right) - \frac{5}{4} = 0 \Rightarrow \frac{1}{4} - \frac{m}{2} - \frac{5}{4} = 0 \Rightarrow m = -2$$

5. The altitude of a right triangle is 7 cm less than its base. If the hypotenuse is 13 cm, the other two sides of the triangle are equal to:

- (a) Base=10cm and Altitude=5cm                      (b) Base=12cm and Altitude=5cm  
(c) Base=14cm and Altitude=10cm                      (d) Base=12cm and Altitude=10cm

**Ans.** (b) Base=12cm and Altitude=5cm

Let the base be x cm., Altitude =  $(x - 7)$  cm

In a right triangle,  $\text{Base}^2 + \text{Altitude}^2 = \text{Hypotenuse}^2$  (From Pythagoras theorem)

$\therefore x^2 + (x - 7)^2 = 13^2$  By solving the above equation, we get;

$\Rightarrow x = 12$  or  $x = -5$  Since the side of the triangle cannot be negative.

Therefore, base = 12cm and altitude =  $12 - 7 = 5$ cm

6. The sum of a number and its reciprocal is  $\frac{65}{8}$  Then the number is:

- (a)  $8, \frac{1}{8}$                                       (b) 4                                      (c) 2                                      (d) 6

**Ans.** (a)  $x = 8, \frac{1}{8}$

Let the number be x then as per condition  $x + \frac{1}{x} = \frac{65}{8}$

$$8x^2 - 65x + 8 = 0, 8x(x-8) - 1(x-8) \text{ so } x = 8, \frac{1}{8}$$

7. If one root of equation  $4x^2 - 2x + k - 4 = 0$  is reciprocal of the other. The value of k is:

- (a) -8                                      (b) 8                                      (c) -4                                      (d) 4

**Ans.** (b) 8

If one root is reciprocal of others, then the product of roots will be:

$$\alpha \times \frac{1}{\alpha} = \frac{k-4}{4} = 1 \Rightarrow k-4=4 \text{ so } k=8$$

8. The value of  $\sqrt{6 + \sqrt{6 + \sqrt{6} \dots \dots \dots}}$  is

- (a) 4                                      (b) 3                                      (c) 3.5                                      (d) -3

**Ans.** (b) 3

Hint: we can write,  $\sqrt{6+x} = x$

$$x^2 - x - 6 = 0 \Rightarrow x^2 - 3x + 2x - 6 = 0 \Rightarrow x(x-3) + 2(x-3) = 0 \Rightarrow (x+2)(x-3) = 0 \Rightarrow x = -2, 3$$

9. Which of the following is not a quadratic equation

- (a)  $x^2 + 3x - 5 = 0$                       (b)  $x^2 + x^3 + 2 = 0$                       (c)  $3 + x + x^2 = 0$                       (d)  $x^2 - 9 = 0$

**Ans.** (b)  $x^2 + x^3 + 2 = 0$ : Since it has degree 3.

10. The equation  $2x^2 + kx + 3 = 0$  has two equal roots, then the value of k is

- (a)  $\pm\sqrt{6}$                                       (b)  $\pm 4$                                       (c)  $\pm 3\sqrt{2}$                                       (d)  $\pm 2\sqrt{6}$

**Ans.** (d)  $\pm 2\sqrt{6}$

Condition for two equal roots is  $b^2 - 4ac = 0$

$$\Rightarrow (k)^2 - 4 \times 2 \times 3 = 0 \Rightarrow k^2 = 24 \Rightarrow k = \pm\sqrt{24} \therefore k = \pm 2\sqrt{6}$$

## ASSERTION AND REASONING QUESTIONS

**Directions:** In the questions below, a statement of Assertion(A) is followed by a statement of Reason(R). Choose the correct option.

- (a) Both Assertion and Reason are true and Reason is the correct explanation of Assertion.  
(b) Both Assertion and Reason are true, but Reason is not the correct explanation of Assertion.  
(c) Assertion is true but Reason is false.  
(d) Assertion is false but Reason is true.
- Assertion(A):**  $3x^2 - 6x + 3 = 0$  has repeated roots.  
**Reason(R):** The quadratic equation  $ax^2 + bx + c = 0$  have repeated roots if discriminant  $D > 0$ .  
**Ans.** (c)
  - Assertion(A):** If one root of the quadratic equation  $6x^2 - x - k = 0$  is  $2/3$ , then the value of  $k$  is 2.  
**Reason(R):** The quadratic equation  $ax^2 + bx + c = 0$ ,  $a \neq 0$  has almost two roots.  
**Ans.** (b)
  - Assertion(A):**  $(2x - 1)^2 - 4x^2 + 5 = 0$  is not a quadratic equation.  
**Reason(R):** An equation of the form  $ax^2 + bx + c = 0$ ,  $a \neq 0$ , where  $a, b, c \in \mathbb{R}$  is called a quadratic equation.  
**Ans.** (a)
  - Assertion(A):** The roots of the quadratic equation  $x^2 + 2x + 2 = 0$  are imaginary  
**Reason(R):** If discriminant  $D = b^2 - 4ac < 0$  then the roots of quadratic equation  $ax^2 + bx + c = 0$  are imaginary.  
**Ans.** (a)
  - Assertion (A):** The quadratic equation  $x^2 + 4x + 5 = 0$  has no real roots.  
**Reason (R):** The discriminant is greater than zero.  
**Ans.** (c)
  - Assertion (A):** The solution of the quadratic equation  $(x-1)^2 - 5(x-1) - 6 = 0$  is 7  
**Reason (R):** The solution of the equation  $x^2 + 5x - (a^2 + a - 6) = 0$  is  $a + 3$   
**Ans.** (c)
  - Assertion (A):** Every quadratic equation has exactly one root.  
**Reason(R):** Every quadratic equation has at most two roots.  
**Ans.** (d)
  - Assertion(A):** If the coefficient of  $x^2$  and the constant term of a quadratic equation have opposite signs, then the quadratic equation has real roots.  
**Reason (R):** Every quadratic equation has at least two roots.  
**Ans.** (c)
  - Assertion(A):** The equation  $x^2 + 4x + 5 = 0$  has two equal roots.  
**Reason (R):** If discriminant  $D = b^2 - 4ac = 0$  then the roots of quadratic equation  $ax^2 + bx + c = 0$  are equal.  
**Ans.** (a)
  - Assertion(A):** The roots of the quadratic equation  $x^2 + 2x + 2 = 0$  are imaginary  
**Reason(R):** If discriminant  $D = b^2 - 4ac < 0$  then the roots of quadratic equation  $ax^2 + bx + c = 0$  are imaginary.  
**Ans.** (a)

### VERY SHORT ANSWER TYPE QUESTIONS (2MARKS QUESTIONS)

- Find the value of  $p$  so that the quadratic equation  $px(x - 3) + 9 = 0$  has two equal roots.  
**Ans:**  $px^2 - 3px + 9 = 0$ , condition for equal roots:  $b^2 - 4ac = 0 \Rightarrow (-3p)^2 - 4(p)(9) = 0$  on solving we get  $p = 0$  (rejected) or  $p = 4 \therefore p = 4$  ( $\because$  Coeff. of  $x^2$  cannot be zero).
- Find the roots of the equation  $x^2 - 3x - m(m + 3) = 0$ , where  $m$  is a constant.

**Ans:**  $D = b^2 - 4ac = (2m + 3)^2$

$$x = \frac{-(-3) \pm \sqrt{(2m+3)^2}}{2(1)} = \frac{3 \pm (2m+3)}{2}$$

$$= \frac{3+2m+3}{2} \text{ or } \frac{3-2m-3}{2}$$

$$x = \frac{2(m+3)}{2} = \frac{-2m}{2}$$

$\therefore x = m + 3$  or  $-m$

3. If 1 is a root of the equations  $ay^2 + ay + 3 = 0$  and  $y^2 + y + b = 0$ , then find the value of  $ab$ .

**Ans:** On putting the value of  $y$  in  $ay^2 + ay + 3 = 0$ , we get  $a = -\frac{3}{2}$

Again, putting the value of  $y$  in  $y^2 + y + b = 0$ , we get  $b = -2$  so  $ab = 3$ .

4. Check if  $x(x + 1) + 8 = (x + 2)(x - 2)$  is in the form of quadratic equation.

**Ans:**  $x(x + 1) + 8 = (x + 2)(x - 2) \Rightarrow x^2 + x + 8 = x^2 - 2^2$ . On simplification we get  $x + 12 = 0$ . Since, this expression is not in the form of  $ax^2 + bx + c$ , hence it is not a quadratic equation.

5. Find two consecutive positive integers, the sum of whose squares is 365.

**Ans:** Let us say, the two consecutive positive integers be  $x$  and  $x + 1$ .

$$x^2 + (x + 1)^2 = 365 \Rightarrow x^2 + x - 182 = 0 \Rightarrow x = -14 \text{ or } x = 13$$

$x + 1 = 13 + 1 = 14$ . so, the two consecutive positive integers will be 13 and 14.

6. Is it possible to design a rectangular park of perimeter 80 and area 400 sq.m.? If so find its length and breadth.

**Ans:** Let the length and breadth of the park be  $L$  and  $B$ .

$$\text{Perimeter of the rectangular park} = 2(L + B) = 80$$

$$\Rightarrow \text{Area of the rectangular park} = L \times B \Rightarrow L^2 - 40L + 400 = 0,$$

on solving the equations we get  $L = 20\text{m}$  and  $B = 20\text{m}$ .

7. If  $x = 3$  is one root of the quadratic equation  $x^2 - 2kx - 6 = 0$ , then find the value of  $k$ .

**Ans:** Given that  $x = 3$  is one root of the quadratic equation  $x^2 - 2kx - 6 = 0$

$$\Rightarrow (3)^2 - 2k(3) - 6 = 0$$

$$\Rightarrow k = \frac{1}{2}$$

8. Find the quadratic polynomial if its zeroes are  $0, \sqrt{5}$ .

**Ans.** A quadratic polynomial can be written using the sum and product of its zeroes as:

$$x^2 - (\alpha + \beta)x + \alpha\beta, \text{ where } \alpha \text{ and } \beta \text{ are the roots of the polynomial. Here, } \alpha = 0 \text{ and } \beta = \sqrt{5},$$

$$\Rightarrow x^2 - (0 + \sqrt{5})x + 0(\sqrt{5}) \Rightarrow x^2 - \sqrt{5}x.$$

9. Find the value of “ $x$ ” in the polynomial  $2a^2 + 2xa + 5a + 10$  if  $(a + x)$  is one of its factors.

**Ans.** Let  $f(a) = 2a^2 + 2xa + 5a + 10$ , Since,  $(a + x)$  is a factor of  $2a^2 + 2xa + 5a + 10$ ,  $f(-x) = 0$

$$\text{So, } f(-x) = 2x^2 - 2x^2 - 5x + 10 = 0 \text{ Therefore, } x = 2.$$

10. How many zeros does the polynomial  $(x - 3)^2 - 4$  have? Also, find its zeroes.

**Ans.** On expanding the given expression, we find  $x^2 - 6x + 5$ . As the polynomial has a degree of 2, the number of zeroes will be 2. On solving  $x^2 - 6x + 5 = 0$  we get the roots  $x = 1, x = 5$ .

### SHORT ANSWER TYPE QUESTIONS (3 MARKS QUESTIONS)

1. Find the discriminant of the equation  $3x^2 - 2x + \frac{1}{3} = 0$  and hence find the nature of its roots. Find them, if they are real.

**Ans.**  $3x^2 - 2x + \frac{1}{3} = 0$ , Since, Discriminant =  $b^2 - 4ac \Rightarrow (-2)^2 - 4 \times 3 \times \frac{1}{3} \Rightarrow 0$

Hence, the given quadratic equation has two equal real roots. The roots are  $\frac{-b}{2a}$  and  $\frac{-b}{2a}$ .

on solving the roots are  $\frac{1}{3}, \frac{1}{3}$

2. Find the value of  $p$ , for which one root of the quadratic equation  $px^2 - 14x + 8 = 0$  is 6 times the other.

**Ans.**  $px^2 - 14x + 8 = 0$ , Let  $\alpha$  and  $6\alpha$  be the roots of the given quadratic equation.

$$\text{Sum of the roots} = -\text{coefficient of } x / \text{coefficient of } x^2 \Rightarrow \alpha + 6\alpha = -(-14)/p \Rightarrow \alpha = 2/p \dots (i)$$

Product of roots = constant term/coefficient of  $x^2 \Rightarrow (\alpha)(6\alpha) = \frac{8}{p}$  on substituting  $\alpha = \frac{2}{p}$

from (i), we get  $p = 3$ .

3. Solve for  $x$ :  $\sqrt{2x+9} + x = 13$ .

**Ans.**  $\sqrt{2x+9} + x = 13$ , on squaring both the sides,  $x^2 - 28x + 160 = 0 \Rightarrow x = 8$  or  $x = 20$

4. Solve for  $x$ :  $4x^2 - 4ax + (a^2 - b^2) = 0$

**Ans.**  $4x^2 - 4ax + (a^2 - b^2) = 0$

$\Rightarrow [4x^2 - 4ax + a^2] - b^2 = 0 \Rightarrow (2x - a)^2 - (b)^2 = 0 \Rightarrow (2x - a + b)(2x - a - b) = 0$

$\Rightarrow 2x - a + b = 0$  or  $2x - a - b = 0 \Rightarrow 2x = a - b$  or  $2x = a + b \therefore x = \frac{(a-b)}{2}$  or  $x = \frac{(a+b)}{2}$

5. Find that value of  $p$  for which the quadratic equation  $(p+1)x^2 - 6(p+1)x + 3(p+9) = 0$ ,  $p \neq -1$  had equal roots.

**Ans.** For the given quadratic equation to have equal roots,  $D = 0$

Here  $a = (p+1)$ ,  $b = -6(p+1)$ ,  $c = 3(p+9)$

$D = b^2 - 4ac$

$\Rightarrow [-6(p+1)]^2 - 4(p+1).3(p+9) = 0 \Rightarrow 36(p+1)^2 - 12(p+1)(p+9) = 0$

$\Rightarrow p+1 = 0$  or  $p-3 = 0 \Rightarrow p = -1$  (rejected) or  $p = 3 \therefore p = 3$ .

6.  $\alpha$  and  $\beta$  are zeroes of the quadratic polynomial  $x^2 - 6x + y$ . Find the value of 'y' if  $3\alpha + 2\beta = 20$ .

**Ans.** Let,  $f(x) = x^2 - 6x + y$  from the given  $3\alpha + 2\beta = 20$ —(i),  $\alpha + \beta = 6$ —(ii) and,  $\alpha\beta = y$ —(iii) on solving  $\alpha = 8$ ,  $\beta = -2$ .  $y = \alpha\beta = (8)(-2) = -16$ .

7. Find two numbers whose sum is 27 and product is 182.

**Ans.** Let us say the first number is  $x$ , and the second number is  $27 - x$ . As per question:

$x(27 - x) = 182 \Rightarrow x^2 - 27x - 182 = 0$ , on solving  $x = 13$  or  $x = 14$  the numbers are 13 and 14

8. The sum of the reciprocals of Rehman's age (in years) 3 years ago and 5 years from now is  $\frac{1}{3}$ . Find his present age.

**Ans.** Let the present age of Rahman is  $x$  years. Three years ago, Rehman's age was  $(x - 3)$  years. Five years after, his age will be  $(x + 5)$  years. As per the condition given

$\therefore \frac{1}{x-3} + \frac{1}{x+5} = \frac{1}{3}$  after simplification we get:  $x^2 - 4x - 21 = 0 \Rightarrow x = 7, -3$

As we know, age cannot be negative. Therefore, Rahman's present age is 7 years

9. In a class test, the sum of Shefali's marks in Mathematics and English is 30. Had she got 2 marks more in Mathematics and 3 marks less in English, the product of their marks would have been 210. Find her marks in the two subjects.

**Ans.** Let us say the marks of Shefali in Math be  $x$ . Then, the marks in English will be  $30 - x$ .

As per the given question,  $(x + 2)(30 - x - 3) = 210$ , on solving the QE we get  $x = 12, 13$

Therefore, if the marks in Math are 12, then marks in English will be  $30 - 12 = 18$ , and if the marks in Math are 13, then marks in English will be  $30 - 13 = 17$ .

10. Sum of the areas of two squares is  $468 \text{ m}^2$ . If the difference between their perimeters is 24 m, find the sides of the two squares.

**Ans.** Let the sides of the two squares be  $x$  m and  $y$  m. Therefore, their perimeter will be  $4x$  and  $4y$ , respectively and the area of the squares will be  $x^2$  and  $y^2$  respectively.

As per question  $4x - 4y = 24$ , Also,  $x^2 + y^2 = 468$ .

By these two equations we obtain QE:  $y^2 + 6y - 216 = 0$ . After simplification we get  $y = -18, 12$ .

As we know, the side of a square cannot be negative.

Hence, the sides of the squares are 12 m and  $(12 + 6) = 18$  m.

### **LONG ANSWER TYPE QUESTIONS (5 MARKS QUESTIONS)**

1. In a flight of 600 km, an aircraft was slowed due to bad weather. Its average speed for the trip was reduced by 200 km/hr and the time of flight increased by 30 minutes. Find the original duration of the flight.

**Ans.** Let the speed of the flight be  $x$  km/hrs. According to the given,  $\frac{600}{x-200} - \frac{600}{x} = \frac{1}{2}$

After simplification we get  $x^2 - 200x - 2400 = 0$ , on solving this QE we obtain

$x = -400$ ,  $x = 600$ , Time cannot be negative. Therefore,  $x = 600$  km/hrs.

Hence, the original duration of the flight is 1 hr.

2. The altitude of a right triangle is 7 cm less than its base. If the hypotenuse is 13 cm, find the other two sides.

**Ans.** Let the base of the right triangle is  $x$  cm, the altitude of right triangle =  $(x - 7)$  cm

By Pythagoras' theorem,  $x^2 + (x - 7)^2 = 13^2$  on solving we get  $x = 12$  or  $x = -5$

Since sides cannot be negative,  $x$  can only be 12. Therefore, the base of the given triangle is 12 cm, and the altitude of this triangle will be  $(12 - 7)$  cm = 5 cm.

3. A cottage industry produces a certain number of pottery articles in a day. It was observed on a particular day that the cost of production of each article (in rupees) was 3 more than twice the number of articles produced on that day. If the total cost of production on that day was Rs.90, find the number of articles produced and the cost of each article.

**Ans.** Let the number of articles produced is  $x$ .

Therefore, cost of production of each article = Rs  $(2x + 3)$ . Given the total cost of production is Rs.90

$\therefore x(2x + 3) = 90$  on solving QE we get  $x = -15/2$  or  $x = 6$ . As the number of articles produced can only be a positive integer,  $x$  can only be 6. Hence, the number of articles produced = 6 so the Cost of each article =  $2 \times 6 + 3 =$  Rs 15.

4. An express train takes 1 hour less than a passenger train to travel 132 km between Mysore and Bangalore (without taking into consideration the time they stop at intermediate stations). If the average speed of the express train is 11 km/h more than that of the passenger train, find the average speed of the two trains.

**Ans.** Let us say the average speed of the passenger train =  $x$  km/h.

Average speed of express train =  $(x + 11)$  km/h. As per question:  $\frac{132}{x} - \frac{132}{x+11} = 1$

On solving Q E  $x^2 + 11x - 1452 = 0 \Rightarrow x = -44, 33$ . As we know, speed cannot be negative.

Therefore, the speed of the passenger train will be 33 km/h and thus, the speed of the express train will be  $33 + 11 = 44$  km/h.

5. The numerator of a fraction is 3 less than its denominator. If 1 is added to the denominator, the fraction is decreased by  $1/15$ . Find the fraction.

**Ans.** Let the denominator be  $x$  and the numerator be  $x - 3$ .  $\therefore$  Fraction =  $\frac{x-3}{x}$

New denominator =  $x + 1$

According to the Question,

$$\Rightarrow \frac{x-3}{x+1} = \frac{x-3}{x} - \frac{1}{15}$$

$$\Rightarrow \frac{x-3}{x+1} = \frac{15x-45-x}{15x}$$

$$\Rightarrow \frac{x-3}{x+1} = \frac{14x-45}{15x}$$

after simplification we get  $\Rightarrow x^2 - 14x + 45 = 0 \Rightarrow x = 5$  or  $x = 9$

When  $x = 5$ , fraction =  $\frac{2}{5}$  When  $x = 9$ , fraction =  $\frac{2}{3}$ .  $\therefore$  Fraction =  $\frac{2}{5}$  or  $\frac{2}{3}$

### **CASE BASED QUESTIOS (4 MARKS QUESTIONS)**

1. Raj and Ajay are very close friends. Both the families decide to go to Ranikhet by their own cars. Raj's car travels at a speed of  $x$  km/h while Ajay's car travels 5 km/h faster than Raj's car. Raj took 4 hours more than Ajay to complete the journey of 400 km.



- (i) What will be the distance covered by Ajay's car in two hours?
- (ii) Write a quadratic equation which describe the speed of Raj's car?
- (iii) What is the speed of Raj's car?
- (iv) How much time took Ajay to travel 400 km?

**Ans.** (I)  $2(x + 5)$ km, (ii)  $x^2 + 5x - 500 = 0$ , (iii) 20km/h, (iv) 16 hours

2. The speed of a motor boat is 20 km/hr. For covering the distance of 15 km the boat took 1 hour more for upstream than downstream.

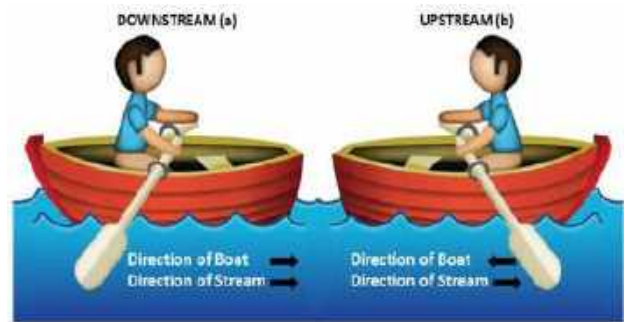

- (i) Let speed of the stream be  $x$  km/hr. then what will be the speed of the motorboat in upstream.
- (ii) Write the correct quadratic equation for the speed of the current?
- (iii) How much time boat took in downstream?
- (iv) What is the speed of the current?

**Ans.** (i)  $(20-x)$  km/h, (ii)  $x^2 + 30x - 400 = 0$ , (iii) 45 minutes, (iv) 10km/h

3. An aero plane travelled a distance of 400km at an average speed of  $x$  km/hr. On the return journey, the speed was increased by 40km/hr.



- (i) Write an expression for times taken for the onward journey.
- (ii) Write an expression for time taken for the return journey.
- (iii) If the return journey took 30 minutes less than the onward journey, then the what is the equation formed in  $x$ .
- (iv) Find the value of equation obtained in question (iii)

**Ans.** (i)  $\frac{400}{x}$  (ii)  $\frac{400}{x+40}$  (iii)  $x^2 + 40x - 32000 = 0$ , (iv) 160

4. Digital images consist of pixels. A pixel can be considered as the smallest unit on a display screen in a mobile or a computer. The number of pixels, their size and colours depend on the display screen and its graphic card. Display screens are rectangular in shape and their size is defined as the length of the diagonal. Amit is designing a web page for a display on a screen whose size is 1000 pixels. The width of the screen is 800 pixels.



- (i) Write a quadratic equation which is used to calculate the height (h) of the screen?  
 (ii) The size of a screen display can be measured in inches also. Is it possible to have a screen of size 13 inches where the width is 7 inches more than height? Give an example to justify.  
 (iii) The size of a screen display can be measured in inches also. Is it possible to have a screen of size 13 inches where the width is 7 inches more than height? Give an example to justify.  
**Ans:** (i)  $h^2 - 200 \times 1800 = 0$ , (ii) Yes, uses Pythagoras' theorem (iii)  $w^2 - 430w + 15,600$
5. Two students Preet and Vihar were solving a particular problem. The problem is as follows. Some students (say 'x') of Kendriya Vidyalaya, planned a picnic during autumn break. The budget for food was Rs. 480. But eight of these failed to go, thus, the cost of food for each member increased by Rs. 10.



Based on the above information answer the following.

- (i) If all students are going to the picnic, then, what is the cost of food for each student?  
 (ii) If 8 students to fail to go then, what is the cost of food per student?  
 (iii) Write the equation to find the value of 'x'.  
 (iv) Solve the equation:  $x^2 - 8x - 384 = 0$

**Ans.** (i)  $\frac{480}{x}$  (ii)  $\frac{480}{x-8}$  (iii)  $x^2 - 8x - 384 = 0$  (iv)  $x = 24$  and  $x = -16$ .

### HIGHER ORDER THINKING SKILL QUESTIONS

1. Two pipes running together can fill a cistern in  $3\frac{1}{13}$  minutes. If one pipe takes 3 minutes more than the other to fill it, find the time in which each pipe would fill the cistern.

**Ans.** Let one pipe fills the cistern in x mins. Therefore, the other pipe will fill the cistern in (x+3) mins. Time taken by both, running together, to fill the cistern =  $3\frac{1}{13}$  mins =  $\frac{40}{13}$  mins

Part filled by one pipe in 1 min =  $\frac{1}{x}$  Part filled by the other pipe in 1 min =  $\frac{1}{x+3}$

Part filled by both pipes, running together, in 1 min =  $\frac{1}{x} + \frac{1}{x+3} = \frac{13}{40}$ .

after simplification we get  $13x^2 - 41x - 120 = 0$

On solving above QE we get  $x = 5$  or  $\frac{-24}{13}$ . Thus, one pipe will take 5 mins and other will take  $\{(5+3)=8\}$  mins to fill the cistern.

2. Solve for x:  $9x^2 - 9(a+b)x + (2a^2 + 5ab + 2b^2) = 0$

**Ans.**  $9x^2 - 9(a+b)x + (2a^2 + 5ab + 2b^2) = 0$ .

The above equation can be rewritten as  $9x^2 - 9(a+b)x + (a+2b)(2a+b) = 0$ .

On solving the above equation, we obtain  $x = \frac{a+2b}{3}$  or  $\frac{2a+b}{3}$ .

3. A lotus is 2m above the water in a pond due to wind the lotus slides on the side and only the stem completely submerges in the water at a distance of 10m from the original position find the depth of the water in the pond.

**Ans.** Let the depth of the pond be x m. According to question  $(x+2)^2 = x^2 + 10^2$ .

On solving the above QE we get  $x = 24$  m. Depth of the pond is 24 m.

4. A teacher on attempting to arrange the students for mass drill in the form of a solid square found that 24 students were leftover. When he increased the size of the square by 1 student he found he was short of 25 students. Find the number of students.

**Ans.** Let the side of the square be x m. No. of students =  $x^2 + 24$ , New side =  $x + 1$ ,

so the number of students =  $(x+1)^2 - 25$ .

ATQ  $x^2 + 24 = (x+1)^2 - 25$ .

On solving we get  $x = 24$ . Number of students =  $576 + 24 = 600$ .

5. X and Y are the centers of circles of radius 9 cm and 2 cm and  $XY = 17$  cm. Z is the center of a circle of radius 4 cm which touches the above circle externally. Given that  $\angle XZY = 90^\circ$  write an equation in r and solve it for r.

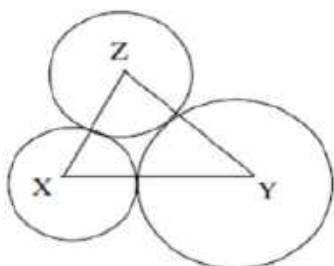

**Ans.** Let r be the radius of third circle.  $XY = 17$  cm

$\Rightarrow XZ = 9 + r$ ,  $YZ = r + 2$ .

ATQ  $(r+9)^2 + (r+2)^2 = 17^2$ .

After simplification we get  $r^2 + 11r - 102 = 0$ , on solving  $r = 6$  cm or  $r = -17$  (not possible), so radius = 6 cm.

# CHAPTER-5 ARITHMETIC PROGRESSIONS

## MIND MAPPING:

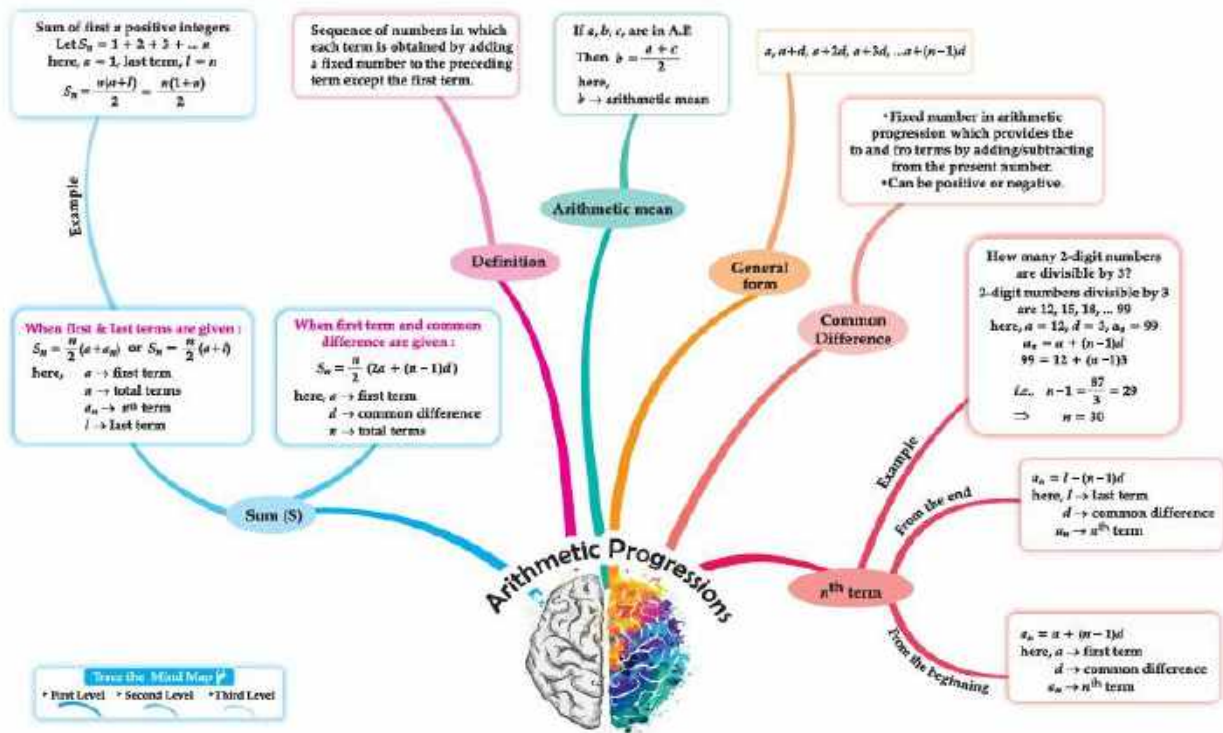

### GIST OF THE CHAPTER

- Introduction
- Arithmetic Progressions
- nth Term of an AP
- Sum of First n Terms of an AP

### DEFINITIONS

1. An arithmetic progression (AP) is a list of numbers in which each term is obtained by adding a fixed number  $d$  to the preceding term, except the first term. The fixed number  $d$  is called the common difference.

The general form of an AP is  $a, a + d, a + 2d, a + 3d, \dots$

2. A given list of numbers  $a_1, a_2, a_3, \dots$  is an AP, if the differences  $a_2 - a_1, a_3 - a_2, a_4 - a_3, \dots$ , give the same value, i.e., if  $a_{k+1} - a_k$  is the same for different values of  $k$ .

3. In an AP with first term  $a$  and common difference  $d$ , the  $n$ th term (or the general term) is given by  $a_n = a + (n - 1)d$ .

4. The sum of the first  $n$  terms of an AP is given by:

$$S = \frac{n}{2} [2a + (n-1)d]$$

5. If  $l$  is the last term of the finite AP, say the  $n$ th term, then the sum of all terms of the AP is given by:

$$S = \frac{n}{2} [a+l]$$

### FORMULAE

- Arithmetic Sequence in general form:  $a, a + d, a + 2d, a + 3d, \dots$
- AP Formula to find common difference:  $d = a_2 - a_1$
- Arithmetic progression formula for  $n$ th term:  $a_n = a + (n - 1)d$ , where 'a' depicts the constant term, 'n' is the number of terms and 'd' is the common difference of the AP.
- The sum of first 'n' terms of arithmetic progression when the  $n$ th term is NOT known is:  

$$S = \frac{n}{2} [2a + (n-1)d]$$

- The sum of first  $n$  terms of an arithmetic progression when the  $n$ th term,  $a_n$  is known: is  $S_n = \frac{n}{2} [a_1 + a_n]$
- The  $n$ th term from the last in an Arithmetic Progression (AP),  $a_n = l - (n - 1)d$  where 'l' is the last term of the AP, 'n' is the term number from the last, and 'd' is the common difference.
- The formula for finding the  $n$ th term ( $a_n$ ) of an arithmetic progression (AP) when the sum of the first  $n$  terms ( $S_n$ ) is given, is:  $a_n = S_n - S_{n-1}$ .  
This formula essentially states that the  $n$ th term is equal to the difference between the sum of the first  $n$  terms and the sum of the first  $(n-1)$  terms.
- If the terms are represented as  $a$ ,  $b$ , and  $c$ , then the relationship is  $2b = a + c$ . In simpler terms, the middle term is the average of the first and third terms.
- If the sum of three terms of an arithmetic progression (AP) is given, then the terms are  $a - d$ ,  $a$ , and  $a + d$ , where 'a' is the first term and 'd' is the common difference.
- If the sum of four terms of an arithmetic progression (AP) is given, then the terms are  $a - 3d$ ,  $a - d$ ,  $a + d$ , and  $a + 3d$ , where 'a' is the first term and 'd' is the common difference.

### MULTIPLE CHOICE QUESTIONS (1 MARK QUESTIONS)

- The  $n^{\text{th}}$  term of an A.P. is given by  $a_n = 3 + 4n$ . The common difference is  
(a) 7 (b) 3 (c) 4 (d) 1  
**Ans:** (c) 4 [  $d = a_2 - a_1, 11 - 7 = 4$  ]
- If  $p$ ,  $q$ ,  $r$  and  $s$  are in A.P. then  $r - q$  is  
(a)  $s - p$  (b)  $s - q$  (c)  $s - r$  (d) none of these  
**Ans:** (c)  $s - r$
- If the sum of three numbers in an A.P. is 9 and their product is 24, then numbers are  
(a) 2, 4, 6 (b) 1, 5, 3 (c) 2, 8, 4 (d) 2, 3, 4  
**Ans:** (d) 2, 3, 4 [ By using three terms  $a-d, a, a+d$  ]
- The  $(n - 1)^{\text{th}}$  term of an A.P. given by 7, 12, 17, 22, ... is  
(a)  $5n + 2$  (b)  $5n + 3$  (c)  $5n - 5$  (d)  $5n - 3$   
**Ans:** (d)  $5n - 3$  [  $a_{n-1} = a + [(n - 1) - 1]d = 7 + [(n - 1) - 1](5) = 7 + (n - 2)5 = 7 + 5n - 10 = 5n - 3$  ]
- The 10<sup>th</sup> term from the end of the A.P. -5, -10, -15, ..., -1000 is  
(a) -955 (b) -945 (c) -950 (d) -965  
**Ans:** (a) -955 [ 10<sup>th</sup> term from the end =  $l - (n - 1)d = -1000 - (10 - 1)(-5) = -1000 + 45 = -955$  ]
- Find the sum of 12 terms of an A.P. whose  $n$ th term is given by  $a_n = 3n + 4$   
(a) 262 (b) 272 (c) 282 (d) 292  
**Ans:** (c) 282 [  $a_1 = 7, a_2 = 10, a_3 = 13, d = 3$ , putting the value in the formula of  $S_n$  we get  
 $S_{12} = \frac{12}{2} [2 \times 7 + (12 - 1) \times 3] = 6[14 + 33] = 6 \times 47 = 282$  ]
- The sum of all two-digit odd numbers is  
(a) 2575 (b) 2475 (c) 2524 (d) 2425  
**Ans:** (b) 2475 [ All two-digit odd numbers are 11, 13, 15, ..., 99, which are in A.P.  
 $\therefore \text{Sum} = \frac{45}{2} [11 + 99] = 452 \times 110 = 45 \times 55 = 2475$  ]
- If  $(p + q)^{\text{th}}$  term of an A.P. is  $m$  and  $(p - q)^{\text{th}}$  term is  $n$ , then  $p$ th term is  
(a)  $mn$  (b)  $\sqrt{mn}$  (c)  $\frac{(m-n)}{2}$  (d)  $\frac{(m+n)}{2}$   
**Ans:** (d)  $\frac{(m+n)}{2}$  [  $a_{p+q} = m, a_{p-q} = n \Rightarrow a + (p + q - 1)d = m \dots (i) \Rightarrow a + (p - q - 1)d = n \dots (ii)$   
On adding (i) and (ii), we get  $2a + (2p - 2)d = m + n \Rightarrow a_n = \frac{(m+n)}{2}$  ]
- The number of multiples lie between  $n$  and  $n^2$  which are divisible by  $n$  is  
(a)  $n + 1$  (b)  $n$  (c)  $n - 1$  (d)  $n - 2$   
**Ans:** (d)  $n - 2$  [ Multiples of  $n$  from 1 to  $n^2$  are  $n \times 1, n \times 2, n \times 3, \dots, n \times n$   
There are  $n$  numbers. Thus, the number of multiples of  $n$  which lie between  $n$  and  $n^2$  is  $(n - 2)$  leaving first and last in the given list: Total numbers are  $(n - 2)$  ]

10. If a, b, c, d, e are in A.P., then the value of  $a - 4b + 6c - 4d + e$  is  
 (a) 0 (b) 1 (c) -1 (d) 2

**Ans:** (a) 0

[ Let common difference of A.P. be  $x$ :  $b = a + x$ ,  $c = a + 2x$ ,  $d = a + 3x$  and  $e = a + 4x$

Given equation  $a - 4b + 6c - 4d + e = a - 4(a + x) + 6(a + 2x) - 4(a + 3x) + (a + 4x)$

$= a - 4a - 4x + 6a + 12x - 4a - 12x + a + 4x = 8a - 8a + 16x - 16x = 0$ ]

### ASSERTION AND REASONING QUESTIONS

**Directions:** In the questions below, a statement of Assertion(A) is followed by a statement of Reason(R). Choose the correct option.

- (a) Both Assertion and Reason are true and Reason is the correct explanation of Assertion.  
 (b) Both Assertion and Reason are true, but Reason is not the correct explanation of Assertion.  
 (c) Assertion is true but Reason is false.  
 (d) Assertion is false but Reason is true.
- Assertion(A):** Let the positive numbers a, b, c be in A.P., then  $\frac{1}{bc}, \frac{1}{ac}, \frac{1}{ab}$  are also in A.P.  
**Reason (R):** If each term of an A.P. is divided by abc, then the resulting sequence is also in A.P.  
**Ans:** (a)
  - Assertion(A):** If  $S_n$  is the sum of the first n terms of an AP, then its nth term  $a_n$  is given by  $a_n = S_n - S_{n-1}$  **Reason (R):** The 10th term of the A.P. 5, 8, 11, 14, ..... is 35.  
**Ans:** (c)
  - Assertion(A):** The sum of the series with the nth term,  $a_n = (9 - 5n)$  is (465), when  $n = 15$ .  
**Reason (R):** Given series is in A.P. and sum of n terms of an A.P. is  $S_n = \frac{n}{2} [2a + (n - 1)d]$   
**Ans:** (d)
  - Assertion (A):** The value of n is 18, if  $a = 10$ ,  $d = 5$ ,  $a_n = 95$   
**Reason (R):** The formula of general term  $a_n$  is  $a_n = a + (n-1)d$ .  
**Ans:** (a)
  - Assertion (A):** The 11th term of an AP 7,9,11, 13,, .....is 67  
**Reason (R):** if  $S_n$  is the sum of first n terms of an AP then its nth term  $a_n$  is given by  $a_n = S_n - S_{n-1}$   
**Ans:** (d)
  - Assertion (A):** The first term of an AP is m and the common difference is p then the 13<sup>th</sup> term is  $a + 10p$   
**Reason (R) :** In an AP,  $a_n = S_n - S_{n-1}$   
**Ans:** (d)
  - Assertion (A):** In an AP,  $S_n = n^2 + n$  then  $a_{20} = 40$   
**Reason (R):** In an AP  $d = a_n - a_{n-1}$   
**Ans:** (b)
  - Assertion (A):** If the nth term of an AP is  $2n^2 - 1$ , then the sum of the first n terms is  $n^3$   
**Reason (R):** If a, l and n are first, last and number of terms of an AP respectively, then  $S_n = \frac{n}{2} (a + l)$   
**Ans:** (d)
  - Assertion (A):** The value of n, if  $a = 10$ ,  $d = 5$ ,  $a_n = 95$ .  
**Reason (R):** The formula of general term  $a_n$  is  $a_n = a + (n-1)d$ .  
**Ans:** (a)
  - Assertion (A):** The nth term of an arithmetic progression is given by  $a_n = a + (n-1)d$ .  
**Reason (R):** In an AP, the difference between any two consecutive terms is constant.  
**Ans:** (a)

### VERY SHORT ANSWER TYPE QUESTIONS (2 MARKS QUESTIONS)

- Find the common difference of the AP  $\frac{1}{p}, \frac{1-p}{p}, \frac{1-2p}{p}, \dots$   
**Ans:** The common difference = -1 [Using  $d = a - a_1$  ]
- Find the 9th term from the end (towards the first term) of the A.P. 5, 9,13, ..., 185.  
**Ans:** n<sup>th</sup> term from the end =  $l - (n - 1)d$ , 9<sup>th</sup> term from the end =  $185 - (9 - 1)4 = 153$

3. Find whether -150 is a term of the A.P. 17, 12, 7, 2, ... ?  
**Ans:** -150 is not the term of given AP. [ using formula of  $a_n$ , we get  $n = \frac{172}{5}$
4. Which term of the progression 20, 192, 183, 17 ... is the first negative term?  
**Ans:** For first negative term,  $a_n < 0$ ,  $n > 27.5$ ∴ Its negative term is 28th term.
5. Find how many two-digit numbers are divisible by 6?  
**Ans:** AP is 12, 18, 24, ...,96 [using the formula,  $a + (n - 1)d = a_n \Rightarrow n = 15$ .]
6. Find the middle term of the A.P. 6, 13, 20, ..., 216?  
**Ans:** using the formula  $a_n = a + (n - 1)d$ , we get  $n=31$ , Middle term =  $(\frac{n+1}{2})^{\text{th}}$  term. 16<sup>th</sup> term,  $a_{16} = 111$
7. How many terms of the A.P. 27, 24, 21, ... should be taken so that their sum is zero?  
**Ans:** Put the value in  $S_n=0$ , we get  $n=19$
8. Find the sum of the first 25 terms of an A.P. whose  $n^{\text{th}}$  term is given by  $a_n = 2 - 3n$ .  
**Ans:** For  $n = 1$ ,  $a_1 = -1$  and for  $n = 25$ ,  $a_{25} = -73$ , using the formula  $S_n = \frac{n}{2}[a_1 + a_n]$ , we get  $S_{25} = -925$ .
9. The first and the last terms of an AP are 8 and 65 respectively. If the sum of all its terms is 730, find its common difference.  
**Ans:** Using  $S_n = 730$ , we get  $n=20$ , using the formula of  $a_n$ , we get  $d=3$
10. A man receives Rs. 60 for the first week and Rs. 3 more each week than the preceding week. How much does he earn by the 20th week?  
**Ans:** AP is 60,63, 66, ..., using the formula  $S_n = \frac{20}{2}[120 + 57] = 1770$ .

### SHORT ANSWER TYPE QUESTIONS (3 MARKS QUESTIONS)

1. The angles of a triangle are in A.P., the least being half the greatest. Find the angles.  
**Ans:** Let the angles be  $a - d$ ,  $a$ ,  $a + d$ ;  $a > 0$ ,  $d > 0$ ,  $a - d + a + a + d = 180^\circ$ ,  
 On solving we get  $a=60^\circ$ ,  $d= 20^\circ$ , the angles are  $40^\circ$ ,  $60^\circ$  and  $80^\circ$ .
2. The 4<sup>th</sup> term of an A.P. is zero. Prove that the 25th term of the A.P. is three times its 11<sup>th</sup> term.  
**Ans:** If  $a_4 = 0$  then  $a + 3d = 0 \Rightarrow a = -3d$ . To prove:  $a_{25} = 3 \times a_{11}$   
 LHS  $= a + 24d = -3d + 24d \Rightarrow 21d$  and RHS  $= 3(a + 10d) \Rightarrow 3(-3d + 10d) \Rightarrow 21d$   
 From above,  $a_{25} = 3(a_{11})$
3. The 7<sup>th</sup> term of an A.P. is 20 and its 13<sup>th</sup> term is 32. Find the A.P.  
**Ans:** On solving two equations which were framed as per the condition given, we get  $a=8$  and  $d=2$ ,  
 so the AP is 8,10,12, ...
4. In an AP, if  $S_5 + S_7 = 167$  and  $S_{10} = 235$ , then find the AP, where  $s$ , denotes the sum of its first  $n$  terms.  
**Ans:** On putting the values in  $S_5 + S_7 = 167$ , we get  $12a + 31d = 167$  and on solving  $S_{10} = 235$  we get  $10a + 45d = 235$ , after simplification we get  $a=1$ ,  $d=5$ .so the A.P. is 1, 6, 11...
5. Which term of the A.P. 3, 14, 25, 36, ... will be 99 more than its 25th term?  
**Ans:** According to the Question,  $a_n = 99 + a_{25} \Rightarrow a + (n - 1) d = 99 + a + 24d$   
 after simplification we get  $n=34$ .
6. The 14<sup>th</sup> term of an AP is twice its 8<sup>th</sup> term. If its 6<sup>th</sup> term is -8, then find the sum of its first 20 terms.  
**Ans:**  $a_{14} = 2a_8$  and  $a_6 = -8$  [Given], after simplification we get  $a=1$  and  $d=-1$ . Now  $S_{20} = -340$
7. If the sum of first 7 terms of an A.P is 49 and that of its first 17 terms is 289, find the sum of first  $n$  terms of the A.P.  
**Ans:** Given:  $S_7 = 49$ ,  $S_{17} = 289$ , on putting the values we get  $2a+6d=14$  and  $2a+16d=34$ ,  
 after simplification we get  $a=1$  and  $d=2$  so  $S_n = n^2$ .
8. The first term of an A.P. is 5, the last term is 45 and the sum of all its terms is 400. Find the number of terms and the common difference of the A.P.  
**Ans:**  $S_n = 400$ , using the formula  $S_n = \frac{n}{2}[a_1 + a_n]$ , we get  $n=16$ , Now,  $a_n = 45$ , on simplification  $d = \frac{8}{3}$

9. Two AP's have the same common difference. The first term for one of these is  $-1$ , and that for the other is  $-8$ . Find the difference for their 4th term.

**Ans:** 1<sup>st</sup> A.P. with the first term  $-1$  as well as the common difference  $d$  is  $-1, -1+d, -1+2d, \dots$

2<sup>nd</sup> A.P. with the first term  $-8$  as well as the common difference  $d$  is  $-8, -8+d, -8+2d, \dots$

The 4th term of first A.P. is:  $a_4 = -1+3d$ ,

The 4th term of second AP is:  $A_4 = -8+3d$

Difference  $a_4 - A_4 = (-1+3d) - (-8+3d) \Rightarrow 7$ .

The difference between their 4th term is 7.

10. An A.P. contains 37 terms. The sum of the three middle most terms is 225 and the sum of the last three is 429. Find out the A.P.

**Ans:** As,  $n = 37$  (odd), Middle term will be  $\frac{n+1}{2}$  th term = 19th term

So, the three middle most terms will be, 18th, 19th and 20th terms.

As per the question,  $a_{18} + a_{19} + a_{20} = 225. \Rightarrow a = 75 - 18d..$  (1),

the last three terms will be 35th, 36th and 37th terms.  $a_{35} + a_{36} + a_{37} = 429$

$a + 35d = 143..$  (2),

On solving  $d=4$  &  $a=3$ , so the AP is 3, 7, 11, ...

### LONG ANSWER TYPE QUESTIONS (5 MARKS QUESTIONS)

1. A contract on construction job specifies a penalty for delay of completion beyond a certain date as follows: Rs. 200 for the first day, Rs. 250 for the second day, Rs. 300 for the third day, etc., the penalty for each succeeding day being Rs. 50 more than for the preceding day. How much money the contractor has to pay as penalty, if he has delayed the work by 30 days.

**Ans:** We can see, that the given penalties are in the form of A.P. having  $a = 200$  and  $d = 50$

Penalty that has to be paid if contractor has delayed the work by 30 days =  $S_{30}$

By the formula of sum of nth term,  $S_{30} = \frac{30}{2} [2(200) + (30 - 1)50] = 27750$

Therefore, the contractor has to pay Rs 27750 as penalty.

2. A sum of Rs 700 is to be used to give seven cash prizes to students of a school for their overall academic performance. If each prize is Rs 20 less than its preceding prize, find the value of each of the prizes.

**Ans:** Let the cost of 1<sup>st</sup> prize be Rs.  $P$ , 2<sup>nd</sup> prize = Rs.  $P - 20$  and cost of 3<sup>rd</sup> prize = Rs.  $P - 40$

We can see that the cost of these prizes are in the form of A.P., having common difference as  $-20$  and first term as  $P$ . Thus,  $a = P$  and  $d = -20$ . Given that,  $S_7 = 700$

By the formula of sum of nth term,  $\frac{7}{2} [2a + (7 - 1)d] = 700$ . On solving  $a = 160$

Therefore, the value of each of the prizes was Rs 160, Rs 140, Rs 120, Rs 100, Rs 80, Rs 60, and Rs 40.

3. In a school, students thought of planting trees in and around the school to reduce air pollution. It was decided that the number of trees, that each section of each class will plant, will be the same as the class, in which they are studying, e.g., a section of class I will plant 1 tree, a section of class II will plant 2 trees and so on till class XII. There are three sections of each class. How many trees will be planted by the students?

**Ans:** It can be observed that the number of trees planted by the students is in an AP.

1, 2, 3, 4, 5, ..... 12 with  $a = 1$  and  $d = 2 - 1 = 1$ ,

by using the formula of  $S_n$ ,  $S_{12} = \frac{12}{2} [2(1) + (12-1)(1)] = 78$

Therefore, number of trees planted by 1 section of the classes = 78, Number of trees planted by 3 sections of the classes =  $3 \times 78 = 234$ . so, 234 trees will be planted.

4. A spiral is made up of successive semicircles, with centres alternately at A and B, starting with centre at A of radii 0.5, 1.0 cm, 1.5 cm, 2.0 cm, ..... as shown in figure. What is the total length of such a spiral made up of thirteen consecutive semicircles? (Take  $\pi = \frac{22}{7}$ )

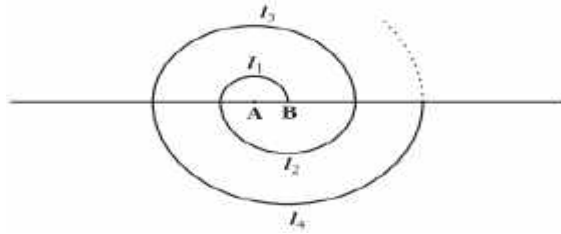

**ANS** Perimeter of a semi-circle =  $\pi r$ . Therefore,  $p_1 = \frac{\pi}{2}$  cm,  $p_2 = \pi$  cm,  $p_3 = \frac{3\pi}{2}$  cm

where,  $p_1, p_2, p_3$  are the lengths of the semi-circles. So the AP is  $\frac{\pi}{2}, \pi, \frac{3\pi}{2}, 2\pi, \dots$

With  $a = \frac{\pi}{2}, d = \frac{\pi}{2}$ , By the sum of n term formula, Sum of the length of 13 consecutive circles is;

$$S_{13} = \frac{13}{2} \left[ 2\left(\frac{\pi}{2}\right) + (13 - 1) \frac{\pi}{2} \right] = 143 \text{ cm}$$

5. 200 logs are stacked in the following manner: 20 logs in the bottom row, 19 in the next row, 18 in the row next to it and so on. In how many rows are the 200 logs placed and how many logs are in the top row?



**Ans:** We can see that the numbers of logs in rows are in the form of an A.P. 20, 19, 18... with  $a = 20$  and

$d = -1$ . Let a total of 200 logs be placed in  $n$  rows. Thus,  $S_n = 200$ . By the sum of nth term formula,  $S_n = \frac{n}{2} [2(20) + (n - 1)(-1)] \Rightarrow n^2 - 41n + 400 = 0$  on solving we get  $n = 16$  or  $n = 25$ .

By the nth term formula, we get  $a_{16} = 5$  and  $a_{25} = -4$ . It can be seen, the number of logs in 16<sup>th</sup> row is 5, as

the numbers cannot be negative.

Therefore, 200 logs can be placed in 16 rows and the number of logs in the 16<sup>th</sup> row is 5.

### **CASE BASED QUESTIONS (4 MARKS QUESTIONS)**

1. India is competitive manufacturing location due to the low cost of manpower and strong technical and engineering capabilities contributing to higher quality production runs. The production of TV sets in a factory increases uniformly by a fixed number every year. It produced 16000 sets in 6th year and 22600 in 9th year.



**Based on the above information, Answer the following questions:**

- (i) Find the production during first year.
- (ii) Find the production during 8th year.
- (iii) Find the production during first 3 years.
- (iv) In which year, the production is Rs 29,200.
- (v) Find the difference of the production during 7th year and 4th year.

**Ans:** (i).Rs 5000,

(ii). Production during 8th year is  $(a+7d) = 5000 + 7(2200) = 20400$

(iii). Production during first 3 year =  $5000 + 7200 + 9400 = 21600$

(iv).  $n = 125$

(v) Difference =  $18200 - 11600 = 6600$ .

2. Anuj gets pocket money from his father everyday. Out of the pocket money, he saves Rs 2.75 on first day, Rs 3 on second day, Rs 3.25 on third day and so on.



On the basis of above information, answer the following questions.

(i) What is the amount saved by Anuj on 14<sup>th</sup> day?

(ii) What is the total amount saved by Anuj in 8 days?

(iii) What is the amount saved by Anuj on 30<sup>th</sup> day?

(iv) What is the total amount saved by him in the month of June, if he starts savings from 1<sup>st</sup> June?

**Ans:** (i) Rs.6

(ii) Rs.29

(iii)Rs.10

(iv)Rs.191.25

3. Your friend Veer wants to participate in a 200m race. He can currently run that distance in 51 seconds and with each day of practice it takes him 2 seconds less. He wants to do in 31 seconds.

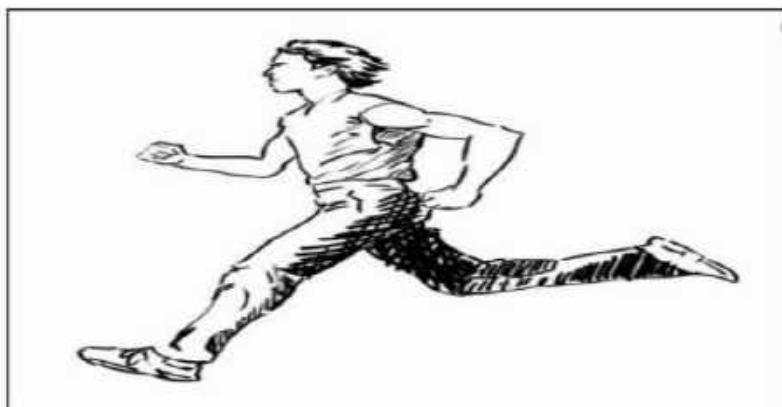

On the basis of the above answer the following questions

(i) Write an AP for the given situation.

(ii)What is the minimum number of days he needs to practice till his goal is achieved.

(iii) If nth term of an AP is given by  $a_n = 2n + 3$  then find the common difference of an AP.

(iv) Find the value of x, for which  $2x, x+ 10, 3x + 2$  are three consecutive terms of an AP.

**Ans:** (i) 51, 49, 47.... ,

(ii) 11,

(iii) 2,

(iv) 6

4. Your elder brother wants to buy a car and plans to take loan from a bank for his car. He repays his total loan of Rs 1,18,000 by paying every month starting with the first instalment of Rs 1000. If he increases the instalment by Rs 100 every month, Answer the following:



- (i) Find the amount paid by him in 30th installment.  
 (ii) Find the amount paid by him in the 30 installments.  
 (iii) What amount does he still have to pay after 30th installment?  
 (iv) If total installments are 40 then find amount paid in the last installment.

**Ans:** (i) 3900, (ii) 73500, (iii) 44500, (iv) 4900

5. Garba is a form of dance which originates from the state of Gujarat in India. The name is derived from the Sanskrit term Garbha. Many traditional garbas are performed around a centrally lit lamp or a picture or statue of the Goddess Shakti. Traditionally, it is performed in circles around this lamp during the nine-day Indian festival Navarātrī.



In the garba ground in a colony, it was decided to fix the participants to 1500. The dancers were to perform in concentric rings in such a way that each succeeding (outer) ring had 10 more participants than the previous (inner) ring.

- (i) If the first ring had place for 30 participants, how many dancers will be there in the 10<sup>th</sup> row?  
 (ii) In how many circles will 1500 dancers dance as per this arrangement?  
 (iii) How many dancers will be left out after 12<sup>th</sup> row?

(iv) Suppose there are 13 circles of dancers, how many dancers are there in the middle ring?

**Ans:** (i)  $a_{10} = 30 + 9 \times 10 = 120$

(ii)  $n = 15,$

(iii) No of dancers left out after 12<sup>th</sup> row =  $1500 - 1020 = 480,$

(iv)  $a_7 = 100$

### HIGHER ORDER THINKING SKILLS

1. Find the '6th' term of the A.P.:  $\frac{2m+1}{m}, \frac{2m-1}{m}, \frac{2m-3}{m}$

**Ans:**  $a = \frac{2m+1}{m}$   $d = \frac{-2}{m}$ ,  $a_6 = \frac{2m+1}{m} + 5 \cdot \frac{-2}{m} \Rightarrow \frac{2m-9}{m}$

2. If  $\frac{a^{n+1}+b^{n+1}}{a^n+b^n}$  is the arithmetic mean between 'a' and 'b', then, find the value of 'n'.

**Ans:** As per given condition

$$\frac{a+b}{2} = \frac{a^{n+1}+b^{n+1}}{a^n+b^n}$$

$$(a^n + b^n)(a + b) = 2(a^{n+1} + b^{n+1}) \Rightarrow a^{n+1} + a^n b + b^n a + b^{n+1} = 2a^{n+1} + 2b^{n+1}$$

$$\Rightarrow a^{n+1} + b^{n+1} = a^n b + b^n a \Rightarrow (a^{n+1} - a^n b) - (b^n a - b^{n+1}) = 0 \Rightarrow a^n (a - b) - b^n (a - b) = 0 \Rightarrow (a^n - b^n) (a - b) = 0$$

$\Rightarrow$  Either  $(a^n - b^n) = 0$  or  $(a - b) = 0$  But  $a \neq b \Rightarrow a - b \neq 0$

$$(a^n - b^n) = 0 \Rightarrow a^n = b^n \Rightarrow \left(\frac{a}{b}\right)^n = 1 \Rightarrow \left(\frac{a}{b}\right)^n = \left(\frac{a}{b}\right)^0 \Rightarrow n = 0.$$

3. If  $p^{\text{th}}$  term of an A.P. is  $\frac{1}{q}$  and  $q^{\text{th}}$  term is  $\frac{1}{p}$ . then prove that the sum of the first 'pq' terms is  $\frac{1}{2}(pq+1)$ .

**Ans:**  $p^{\text{th}}$  term =  $a_n = a + (n - 1) d = \frac{1}{q}$  ....(1)  $q^{\text{th}}$  term =  $a_n = a + (n - 1) d = \frac{1}{p}$  ....(2)

Subtracting (2) from (1), we obtain  $\Rightarrow d = \frac{1}{pq}$ ,  $\Rightarrow a = \frac{1}{pq}$ . By applying the formula

$$S_{pq} = \frac{pq}{2} [2a + (pq - 1) d]$$

$$S_{pq} = \frac{pq}{2} \left[ \frac{2}{pq} + (pq - 1) \frac{1}{pq} \right] = \frac{1}{2} (pq + 1)$$

Thus, the sum of the first pq terms of the A.P is  $\frac{1}{2} (pq + 1)$

4. Solve the equation:  $1 + 4 + 7 + 10 + \dots + x = 287$

**Ans:** Given, the sum of the terms up to x is 287. Here  $a=1$ ,  $d=3$ , using the formula of  $S_n$  we get  $3n^2 - n - 574 = 0$ .

On solving the QE we get  $n=14$  and  $-\frac{41}{3}$

Since a negative term is not possible,  $n = -\frac{41}{3}$  is neglected.

Now we use the formula  $a_n = a + (n - 1)d$ ,

So,  $x = 1 + (14 - 1)(3) \Rightarrow x = 40$ .

5. Find three numbers in A.P. whose sum is 21 and their product is 231.

**Ans:** Let the three consecutive terms be  $a - d$ ,  $a$ ,  $a + d$ ,

as per the condition:  $a - d + a + a + d = 21 \Rightarrow 3a = 21 \Rightarrow a = 7$

Given;  $(7 - d)(7)(7 + d) = 231 \Rightarrow (7 - d)(7 + d) = 33$

$$\Rightarrow 49 - d^2 = 33 \Rightarrow d^2 = 16 \Rightarrow d = -4, 4.$$

The AP is 11, 7, 3 or 3, 7, 11.

# CHAPTER- 6 TRIANGLES MIND MAPPING

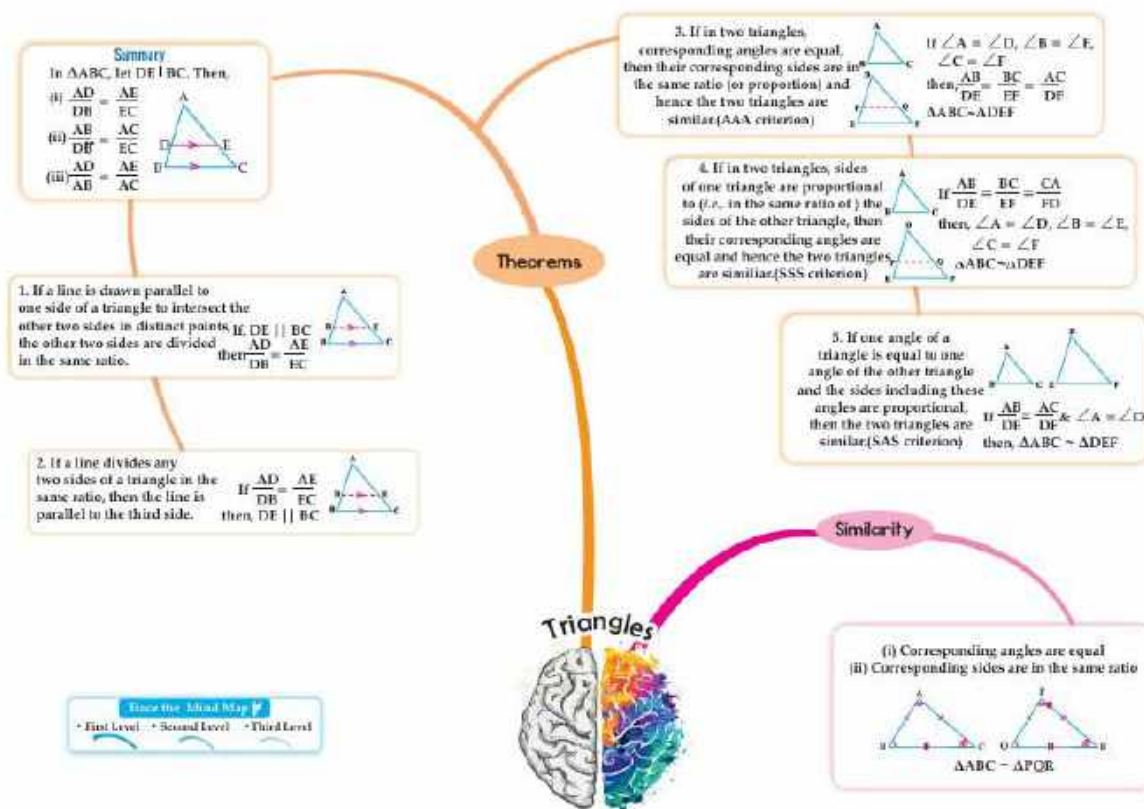

## Concepts:

### I. Criteria for similarity of Triangles

- If in two triangles, corresponding angles are equal, then their corresponding sides are in the same ratio (or proportion) and hence the two triangles are similar. (AAA criterion)
- If in two triangles, sides of one triangle are proportional to (in the same ratio of) the i.e., sides of the other triangle, then their corresponding angles are equal and hence the two triangles are similar. (SSS criterion)
- If one angle of a triangle is equal to one angle of the other triangle and the sides including these angles are proportional, then the two triangles are similar. (SAS criterion)

### II. Theorems:

Basic Proportionality Theorem (BPT) (Thales Theorem)

Proof :

Video link: <https://youtu.be/qdC3hs4hBsQ?si=eBS4sgLeL8MF5otp>

Converse of BPT (Proof is not required)



If a line divides any two sides of a triangle in the same ratio, then the line is parallel to the third side.

### MULTIPLE CHOICE QUESTIONS (1 MARK QUESTIONS)

1. If in  $\triangle ABC$  and  $\triangle PQR$ , we have  $\frac{AB}{QR} = \frac{BC}{PR} = \frac{CA}{PQ}$  then:

(a)  $\triangle PQR \sim \triangle CAB$

(b)  $\triangle PQR \sim \triangle ABC$

(c)  $\triangle CBA \sim \triangle PQR$

(d)  $\triangle BCA \sim \triangle PQR$

**Ans.** (a)  $\triangle PQR \sim \triangle CAB$

2. Which of the following is NOT a similarity criterion?

(a) AA

(b) SAS

(c) AAA

(d) RHS

**Ans.** (d) RHS

3. In  $\Delta ABC$ ,  $DE \parallel AB$ . If  $AB = a$ ,  $DE = x$ ,  $BE = b$  and  $EC = c$ , then  $x$  in terms of  $a, b$  and  $c$ .

- (a)  $\frac{ac}{b}$  (b)  $\frac{ac}{b+c}$  (c)  $\frac{ab}{c}$  (d)  $\frac{ab}{b+c}$

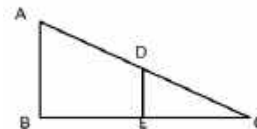

Ans. (b)  $\frac{ac}{b+c}$

4. In the given figure, if  $AB \parallel QR$ , the value of  $x =$

- (a) 3 cm (b) 4 cm (c) 5 cm (d) 6 cm

Ans. (c) 5 cm

Here,  $\Delta PAB \sim \Delta PQR$ ,  $\frac{QR}{AB} = \frac{PQ}{PA}$ ,  $\frac{x}{2} = \frac{3.6+2.4}{2.4}$ ,  $\frac{x}{2} = \frac{6}{2.4}$ ,  $x = \frac{6 \times 2}{2.4} = 5$  cm.

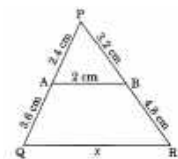

5. In trapezium ABCD,  $AB \parallel CD$ ,  $AB = 3$  cm. The diagonals AC and BD intersect at O such that  $\frac{AO}{CO} = \frac{BO}{DO} = \frac{1}{2}$ , then,  $CD =$  \_\_\_\_\_ cm.

- (a) 3 (b) 4 (c) 5 (d) 6

Ans. (d) 6

Given :  $\frac{AO}{CO} = \frac{BO}{DO} = \frac{1}{2}$ , by SAS rule,  $\Delta AOB \sim \Delta COD$ . So,  $\frac{AB}{DC} = \frac{1}{2}$ ,  $\frac{3}{DC} = \frac{1}{2}$ ,  $DC = 6$  cm.

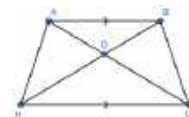

6. The perimeters of two similar triangles are 25cm and 15 cm respectively. One side of the first triangle is 10 cm. The length of the corresponding side of the second triangle is

- (a) 4 cm (b) 5 cm (c) 6 cm (d) 10 cm

Ans. (c) 6 cm

The ratio of the perimeters of similar triangles are same as the ratio of the corresponding sides.

So,  $25:15 = 10$ : corresponding side of the second triangle  $\therefore$  side = 6 cm.

7. In the given figure, if  $\Delta ABP \sim \Delta DCP$ ,

the value of  $\angle B =$

- (a)  $30^\circ$  (b)  $50^\circ$  (c)  $80^\circ$  (d) 10

Ans. (d)  $100^\circ$   $\angle APB = \angle DPC = 50^\circ$

Here  $\Delta ABP \sim \Delta DCP$ ,  $\angle B = \angle C = 180^\circ - (\angle DPC + \angle D) = 180^\circ - (30^\circ + 50^\circ) = 100^\circ$ .

8. In the given figure  $DE \parallel BC$ , if  $AD = 5.6$ cm,  $DB = 4$ cm and  $AE = 7$ cm then, what will be the value of  $AC$ ?

- (a) 2.8cm (b) 5.6cm (c) 5 cm. (d) 12 cm.

Ans. (d) 12 cm

Here  $\frac{AD}{DB} = \frac{AE}{EC}$ ,  $\frac{5.6}{4} = \frac{7}{EC}$ ,  $EC = \frac{4 \times 7}{5.6} = \frac{28}{5.6} = 5$  cm. So,  $AC = AE + EC = 7 + 5 = 12$ cm.

9. In the given figure if  $DE \parallel BC$ ,  $AD=3$  cm,  $BD = 4$ cm and  $BC = 14$ cm, then  $DE$  equals to

- (a) 7cm (b) 6cm (c) 4cm (d) 3cm

Ans: (b) 6cm  $\Delta ADE \sim \Delta ABC$  (by AA similarity)

$\therefore \frac{DE}{BC} = \frac{AD}{AB}$ ,  $\frac{DE}{14} = \frac{3}{3+4}$ ,  $DE = \frac{3 \times 14}{3+4} = \frac{42}{7} = 6$  cm.

10. In  $\Delta ABC$ , if  $DE \parallel BC$ , then the value of  $x$  is \_\_\_\_\_

- (a) 1 (b) 2 (c) 3 (d) 4

Ans: (c) 3

$\frac{AD}{DB} = \frac{AE}{EC}$ ,  $\frac{x}{x+1} = \frac{x+3}{x+5}$ ,  $x^2 + 4x + 3 = x^2 + 5x$ ,  $x = 3$

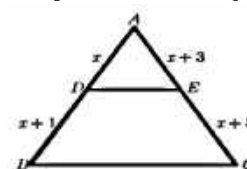
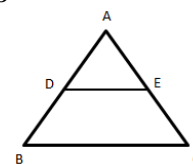
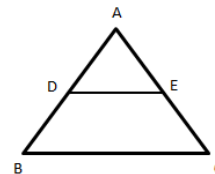
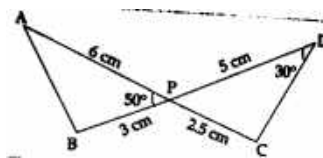

### ASSERTION AND REASONING BASED QUESTIONS

**Directions:** In the questions below, a statement of Assertion(A) is followed by a statement of Reason(R). Choose the correct option.

- (a) Both Assertion and Reason are true and Reason is the correct explanation of Assertion.  
 (b) Both Assertion and Reason are true, but Reason is not the correct explanation of Assertion.  
 (c) Assertion is true but Reason is false.  
 (d) Assertion is false but Reason is true.

**1. Assertion (A):** If two angles of one triangle are respectively equal to two angles of another triangle, then the triangles are similar.

**Reason (R):** If two angles of one triangle are equal to two angles of another triangle, then the third angle is also equal.

**Ans:** (a)

**2. Assertion (A):** Two right triangles are similar if the hypotenuse and one side of one triangle are proportional to the hypotenuse and one side of another triangle.

**Reason (R):** AAA is the only criterion for similarity in right triangles.

**Ans:** (c)

**3. Assertion (A):** If a line is drawn parallel to one side of a triangle to intersect the other two sides, it divides the sides in the same ratio.

**Reason (R):** In any triangle, the line drawn from the midpoint of one side to the midpoint of another side is parallel to the third side.

**Ans :** (b)

**4. Assertion (A):** All congruent triangles are similar.

**Reason (R):** Congruent triangles have equal corresponding sides and equal corresponding angles.

**Ans:** (a)

**5. Assertion (A):** Two triangles are similar if their corresponding sides are in the same ratio.

**Reason (R):** This condition is known as the SSS criterion of similarity.

**Ans:**(a).

**6. Assertion (A):** In triangle ABC, if D and E are points on AB and AC respectively such that  $DE \parallel BC$ , then  $\triangle ADE \sim \triangle ABC$ .

**Reason (R):** A line parallel to one side of a triangle divides the other two sides proportionally and corresponding angles are equal.

**Ans:** (a)

**7. Assertion (A):** The SSS criterion is sufficient to prove the similarity of two triangles.

**Reason (R):** All corresponding angles will be equal if the sides are proportional.

**Ans:** (a)

**8. Assertion (A):** If in triangles ABC and PQR,  $\angle A = \angle P$ ,  $\angle B = \angle Q$  and  $\angle C = \angle R$ , then the triangles are similar.

**Reason (R):** If all angles of one triangle are equal to all angles of another triangle, the corresponding sides are also equal.

**Ans:** (c)

**9. Assertion (A):** Two triangles having equal corresponding angles are always congruent.

**Reason (R):** All congruent triangles are similar.

**Ans:** (d)

**10. Assertion (A):** In and, if  $PQ/XY = QR/YZ = RP/ZX$ , then  $\triangle PQR \sim \triangle XYZ$

**Reason (R):** The SSS similarity criterion uses the equality of angles.

**Ans:** (c)

### VERY SHORT ANSWER TYPE QUESTIONS (2 MARKS QUESTIONS)

1. In the given figure  $AB \parallel DE$ ,  $BD \parallel EF$ . Prove that  $DC^2 = CF \times AC$ .

Ans. In  $\triangle CAB$ ,  $DE \parallel AB$ ,  $\therefore \frac{DC}{AC} = \frac{CE}{BC}$  (By BPT)----(i)

In  $\triangle CDB$ ,  $EF \parallel BD$ ,  $\therefore \frac{CF}{DC} = \frac{CE}{BC}$  (By BPT)----(ii)

From (i) and (ii)  $\frac{DC}{AC} = \frac{CF}{DC} \therefore DC^2 = CF \times AC$ .

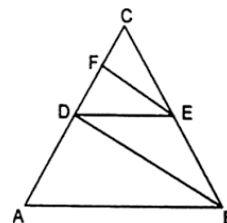

2. In the given figure,  $\frac{EA}{EC} = \frac{EB}{ED}$ , prove that  $\triangle EAB \sim \triangle ECD$

Ans. Given,  $\frac{EA}{EC} = \frac{EB}{ED}$

$\angle AEB = \angle CED$  (Vertically opposite angles)

$\therefore \triangle EAB \sim \triangle ECD$  (SAS similarity Criteria)

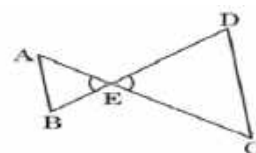

3. X is a point on the side BC of  $\triangle ABC$ . XM and XN are drawn parallel to AB and AC respectively meeting AB in N and AC in M. MN produced meets CB produced at T. Prove that  $TX^2 = TB \times TC$ .

Ans. In  $\triangle TXM$ ,  $XM \parallel BN \therefore \frac{TB}{TX} = \frac{TN}{TM}$  .....(1)

In  $\triangle TMC$ ,  $\frac{TX}{TC} = \frac{TN}{TM}$  .....(2)

From 1 and 2, we have  $\frac{TB}{TX} = \frac{TX}{TC} \therefore TX^2 = TB \times TC$ .

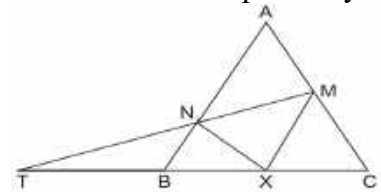

4. In the given figure,  $AP = 3$  cm,  $AR = 4.5$  cm,  $AQ = 6$  cm,  $AB = 5$  cm,  $AC = 10$  cm. Find the length of AD

Ans: In  $\triangle ABC$ ,

$$\frac{AP}{AB} = \frac{3}{5} \quad \dots\dots (i)$$

$$\frac{AQ}{AC} = \frac{6}{10} = \frac{3}{5} \quad \dots\dots (ii)$$

From (i) and (ii), we get  $\frac{AP}{AB} = \frac{AQ}{AC} \Rightarrow PQ \parallel BC$

$$\text{In } \triangle ABD, PR \parallel BD \Rightarrow \frac{AP}{AB} = \frac{AR}{AD} \Rightarrow \frac{3}{5} = \frac{4.5}{AD} \Rightarrow AD = 7.5 \text{ cm}$$

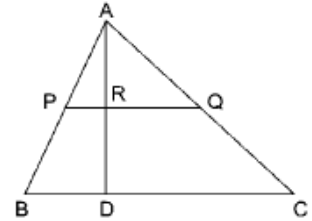

5. In Figure, PQ is parallel to MN. If  $\frac{KP}{PM} = \frac{4}{13}$  and  $KN = 20.4$  cm. Find KQ.

Ans: In  $\triangle KMN$ , we have  $PQ \parallel MN$

$$\therefore \frac{KP}{PM} = \frac{KQ}{QN} \quad \text{[Basic proportionality Theorem]}$$

$$\Rightarrow \frac{KP}{PM} = \frac{KQ}{KN - KQ} \Rightarrow \frac{4}{13} = \frac{KQ}{20.4 - KQ}$$

$$\Rightarrow 4(20.4 - KQ) = 13KQ$$

$$\Rightarrow 81.6 - 4KQ = 13KQ$$

$$\Rightarrow 17KQ = 81.6$$

$$KQ = \frac{81.6}{17} = 4.8 \text{ cm}$$

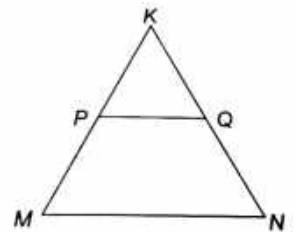

6. In the below figure, if  $ST \parallel QR$ . Find PS.

Ans. By Basic proportionality theorem,

$$\frac{PS}{QS} = \frac{PT}{RT}$$

$$\Rightarrow \frac{PS}{3} = \frac{3}{2} \Rightarrow PS = \frac{9}{2} \text{ cm}$$

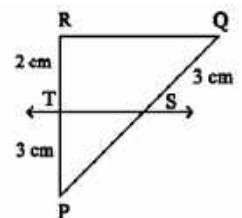

7. In the given figure, if ABCD is a trapezium in which  $AB \parallel DC \parallel EF$ , then prove that  $\frac{AE}{ED} = \frac{BF}{FC}$

Ans. Given  $AB \parallel DC \parallel EF$

Join BD intersecting EF at G.

In  $\triangle DAB$ ,  $EG \parallel AB$

$$\frac{AE}{DE} = \frac{BG}{DG} \quad \text{(BPT)} \quad \dots\dots(i)$$

In  $\triangle DBC$ ,  $GF \parallel DC$

$$\frac{BG}{GD} = \frac{BF}{FC} \quad \text{(BPT)} \quad \dots\dots(ii)$$

From (i) & (ii)

$$\frac{AE}{DE} = \frac{BF}{FC}$$

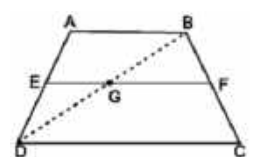
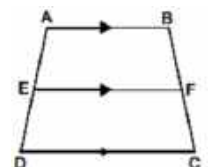

8. In the figure  $\frac{QR}{QS} = \frac{QT}{PR}$  and  $\angle 1 = \angle 2$ . Show that  $\Delta PQS \sim \Delta TQR$ .

ANS. In  $\Delta PQR$ ,  $\angle PQR = \angle PRQ$

$\therefore PQ = PR$  (i)

Given,  $\frac{QR}{QS} = \frac{QT}{PR} \therefore \frac{QR}{QS} = \frac{QT}{QP}$

In  $\Delta PQS$  and  $\Delta TQR$ ,  $\frac{QR}{QS} = \frac{QT}{QP}$  and  $\angle Q = \angle Q$

$\therefore \Delta PQS \sim \Delta TQR$  [SAS similarity criterion]

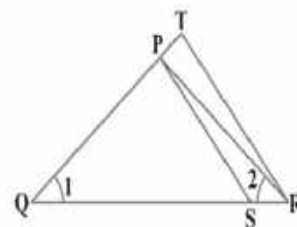

9. In the given figure, ABC and AMP are two right triangles, right angled at B and M respectively, prove that: (i)  $\Delta ABC \sim \Delta AMP$

(ii)  $\frac{CA}{PA} = \frac{BC}{MP}$

Ans. In  $\Delta ABC$  and  $\Delta AMP$ ,

$\angle ABC = \angle AMP$  (Each  $90^\circ$ )  $\angle A = \angle A$  (Common)

$\therefore \Delta ABC \sim \Delta AMP$  (By AA similarity criterion)

$\therefore \frac{CA}{PA} = \frac{BC}{MP}$  (Corresponding sides of similar triangles)

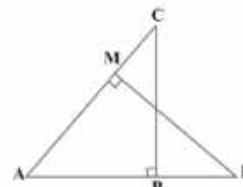

10. S and T are point on sides PR and QR of  $\Delta PQR$  such that  $\angle P = \angle RTS$ .

Show that  $\Delta RPQ \sim \Delta RTS$ .

Ans. In  $\Delta RPQ$  and  $\Delta RTS$ ,  $\angle RTS = \angle QPS$  (Given)

$\angle R = \angle R$  (Common angle)

$\therefore \Delta RPQ \sim \Delta RTS$  (By AA similarity criterion)

**SHORT ANSWER TYPE QUESTIONS (3 MARKS QUESTIONS)**

1. In  $\Delta ABC$ , D, E and F are midpoints of BC, CA and AB respectively. Prove that  $\Delta FBD \sim \Delta DEF$  and  $\Delta DEF \sim \Delta ABC$

Ans.  $\because$  D, E, F are the mid points of BC, CA, AB respectively,  $EF \parallel BC$ ,  $DF \parallel AC$ ,  $DE \parallel AB$

So, BDEF is a parallelogram,  $\angle DBF = \angle FED$ ,  $\angle BDF = \angle EFD \therefore \Delta FBD \sim \Delta DEF$

and also, DCEF is parallelogram,  $\therefore \Delta DEF \sim \Delta ABC$

2. Sides AB and AC and median AD of a triangle ABC are respectively proportional to sides PQ and PR and median PM of another triangle PQR. Show that  $\Delta ABC \sim \Delta PQR$

Ans. Given that,  $\frac{AB}{PQ} = \frac{BC}{QR} = \frac{AD}{PM} \therefore \frac{AB}{PQ} = \frac{2BD}{2QM} = \frac{AD}{PM} \therefore \frac{AB}{PQ} = \frac{BD}{QM} = \frac{AD}{PM} \dots (1)$

$\therefore \Delta ABD \sim \Delta PQM \therefore \angle B = \angle Q$

Now in  $\Delta s$  ABC and PQR,  $\frac{AB}{PQ} = \frac{BC}{QR}$  and  $\angle B = \angle Q$

$\therefore \Delta ABC \sim \Delta PQR$

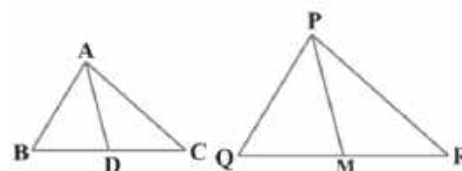

3. A vertical pole of a length 6 m casts a shadow 4m long on the ground and at the same time a tower casts a shadow 28 m long. Find the height of the tower.

Ans. Let AB and CD be a tower and a pole respectively. Let the shadow of BE and DF be the shadow of AB and CD respectively. At the same time, the light rays from the sun will fall on the tower and the pole at the same angle.

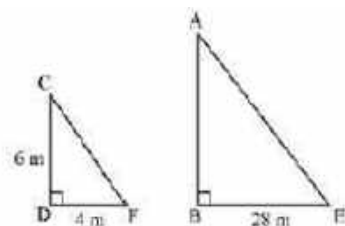

Therefore,  $\angle DCF = \angle BAE$  And,  $\angle CDF = \angle ABE$  (Tower and pole are vertical to the ground)

$\therefore \Delta ABE \sim \Delta CDF$  (AAA similarity criterion)

$\frac{AB}{CD} = \frac{BE}{DF}$ ,  $\frac{AB}{6} = \frac{28}{4} \therefore AB = 42\text{m}$ .

4. In the given figure, ABCD is a quadrilateral.

Diagonal BD bisects both  $\angle B$  and  $\angle D$ . Show that:

(i)  $\triangle ABD \sim \triangle CBD$  (ii)  $AB=BC$

Ans. (i) BD bisects  $\angle B$  and  $\angle D$ , so:  $\angle ABD = \angle CBD$  and  $\angle ADB = \angle CDB$

BD is common in both triangles.

Therefore,  $\triangle ABD \sim \triangle CBD$  by ASA (Angle-Side-Angle)

5. E is a point on the side AD produced of a parallelogram ABCD and BE intersects CD at F. Show that  $\triangle ABE \sim \triangle CFB$ .

Ans.  $AB \parallel DC$  and  $AB = DC$  (opposite sides of a parallelogram)

$AD \parallel BC$  and  $AD = BC$

$\angle ABE = \angle CFB$  (alternate interior angles)

$\angle AEB = \angle CBF$  (VOA)  $\angle ABE = \angle CFB$   $\angle AEB = \angle CBF$

Therefore,  $\triangle ABE \sim \triangle CFB$  by AA similarity

6. In  $\triangle ABC$ ,  $\angle ACB = 90^\circ$  and  $CD \perp AB$ , Prove that  $\frac{BC^2}{AC^2} = \frac{BD}{AD}$ .

Ans.  $\triangle ABC \sim \triangle CBD \therefore BC^2 = AB \cdot BD$  ---(1)

$\triangle ABC \sim \triangle ACD \therefore AC^2 = AB \cdot AD$  ---(2)

Dividing (1) by (2) we get  $\frac{BC^2}{AC^2} = \frac{BD}{AD}$ .

7. If three parallel lines are intersected by two transversals, then prove that the intercepts made by them on the transversals are proportional.

Ans. Let  $l_1 \parallel l_2 \parallel l_3$ , Join BE.

In  $\triangle ABE$ ,  $\frac{AC}{CE} = \frac{BX}{XE}$ , In  $\triangle BEF$ ,  $\frac{BX}{XE} = \frac{BD}{DF} \therefore \frac{AC}{CE} = \frac{BD}{DF}$ .

8. A street light bulb is fixed on a pole 6 m above the level of the street. If a woman of height 1.5 m casts a shadow of 3 m, find how far she is away from the base of the pole.

Ans. Let AB be the pole and CD the woman.

$\triangle ABC \sim \triangle CDE \therefore \frac{AB}{CD} = \frac{BE}{EE} \therefore \frac{6}{1.5} = \frac{3+BD}{3} \therefore BD = 9$  m.

9. In the following figure, A, B and C are points on OP, OQ and OR respectively such that  $AB \parallel PQ$  and  $AC \parallel PR$ . Show that  $BC \parallel QR$ .

Ans. In  $\triangle POQ$ ,  $AB \parallel PQ \therefore \frac{OA}{AP} = \frac{OB}{BQ}$  (Basic proportionality theorem) --- (i)

In  $\triangle POR$ ,  $AC \parallel PR \therefore \frac{OA}{AP} = \frac{OC}{CR}$  (Basic proportionality theorem) ---(ii)

From (i) and (ii), we obtain  $\frac{OB}{BQ} = \frac{OC}{CR}$

$\therefore BC \parallel QR$  (By the converse of basic proportionality theorem)

10. In the following figure,  $DE \parallel OQ$  and  $DF \parallel OR$ , show that  $EF \parallel QR$ .

Ans. In  $\triangle POQ$ ,  $DE \parallel OQ \therefore \frac{PE}{EQ} = \frac{PD}{DO}$  (basic proportionality theorem) (i)

In  $\triangle POR$ ,  $DF \parallel OR \therefore \frac{PF}{FR} = \frac{PD}{DO}$  (basic proportionality theorem) (ii)

From (i) and (ii), we obtain  $\frac{PE}{EQ} = \frac{PF}{FR}$

$\therefore EF \parallel QR$ .

### LONG ANSWER TYPE QUESTIONS (5 MARKS QUESTIONS)

1. D is a point on the side BC of a triangle ABC such that  $\angle ADC = \angle BAC$ , prove that  $CA^2 = CB \cdot CD$

Ans. In  $\triangle ABC$ , D is a point on side BC such that  $\angle ADC = \angle BAC$

In  $\triangle CBA$  and  $\triangle CDA$

$\angle C = \angle C$  (common)

$\angle BAC = \angle ADC$  (given)

$\therefore \triangle CBA \sim \triangle CAD$  (By AA similarity)

$\therefore$  their corresponding sides are proportional

$\therefore \frac{CB}{CA} = \frac{CA}{CD} \therefore CA^2 = CB \cdot CD$

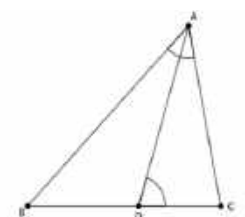
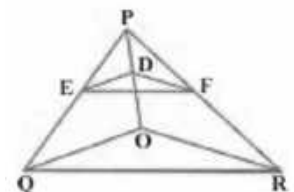
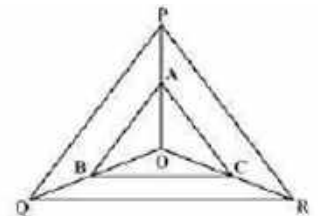
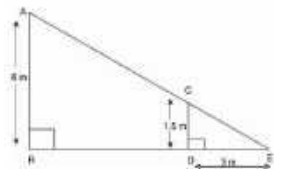
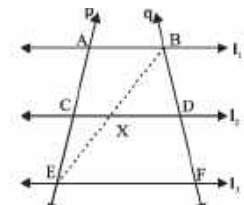
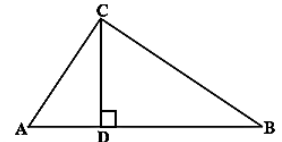
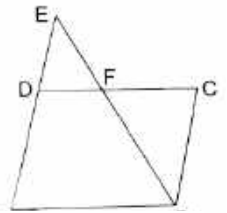
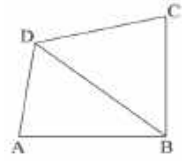

2.State and Prove Thales theorem.

Ans:



3. (i) Prove that if a line is drawn parallel to one side of a triangle to intersect the other two sides in distinct points, the other two sides are divided in the same ratio.

(ii) Using the above theorem, prove that if ABCD is a trapezium in which AB || DC and its diagonals intersect each other at the point E  $\frac{AE}{BE} = \frac{CE}{DE}$ .

Ans. (i) BPT---- same as the answer of question 2.

(ii) ABCD is a trapezium with AB || DC. diagonals intersect each other at point E.

Draw EO || AB

Draw EO || AB

In  $\Delta ABD$  EO || AB, hence  $\frac{AO}{DO} = \frac{BE}{DE}$  (BPT).....(i)

In  $\Delta ACD$  EO || DC, Hence  $\frac{AO}{DO} = \frac{AE}{CE}$  (BPT).....(ii)

From (i) and (ii)  $\frac{AE}{BE} = \frac{CE}{DE}$ .

4. Sides AB and AC and median AD of a triangle ABC are respectively proportional to sides PQ and PR and median PM of another triangle PQR. Show that  $\Delta ABC \sim \Delta PQR$ .

Ans:



5. If AD and PM are medians of triangles ABC and PQR, respectively where  $\Delta ABC \sim \Delta PQR$  Prove that  $\frac{AB}{PQ} = \frac{AD}{PM}$ .

Ans.  $\Delta ABC \sim \Delta PQR$ .  $\therefore \frac{AB}{PQ} = \frac{BC}{QR} = \frac{AC}{PR} \dots (1)$

Also,  $\angle A = \angle P, \angle B = \angle Q, \angle C = \angle R \dots (2)$

Since AD and PM are medians,  $BD = \frac{BC}{2}$  and  $QM = \frac{QR}{2} \dots (3)$

From (1) and (3),  $\frac{AB}{PQ} = \frac{BD}{QM}$ .

In  $\Delta ABD$  and  $\Delta PQM$ ,  $\angle B = \angle Q$  AND  $\frac{AB}{PQ} = \frac{BD}{QM} \dots$

$\therefore \Delta ABD \sim \Delta PQM$  (By SAS similarity criterion  $\therefore \frac{AB}{PQ} = \frac{BD}{QM} = \frac{AD}{PM}$ .)

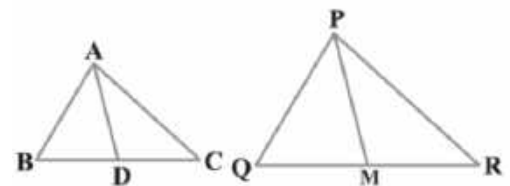

### CASE BASED QUESTIONS(4 MARKS QUESTIONS)

1. Sharon went to a park with her father. From a point A where Sharon was standing, her father and tip of a tree come in a straight line as shown in the figure. She remembers lesson on similar triangles. She asked her father to stay in that place and tried to estimate the height of the tree. Based on this information, answer the following questions.

(i) By what criterion are the triangles  $\Delta ABC$  and  $\Delta ADE$  similar?

(ii) Write the ratios of corresponding sides of the triangles in the above question.

(iii)(a) Find the height of the tree.

(OR)

(iii)(b) If a 6 feet flag staff forms a shadow of 15 feet on the ground, find the height of the tree which forms a shadow of 60 feet at the same time.

A. i) AA similarity criterion ( as  $\angle A = \angle A$  &  $\angle ABC = \angle ADE$ )

(ii)  $\frac{AB}{AD} = \frac{BC}{DE} = \frac{AC}{AE}$

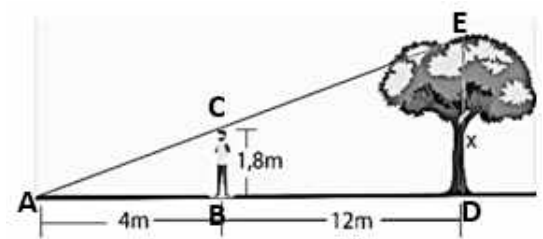

(iii) (a)  $\frac{AB}{AD} = \frac{BC}{DE} \therefore \frac{AB}{AB+BD} = \frac{BC}{DE} \therefore \frac{4}{16} = \frac{1.8}{DE} \therefore DE = 4 \times 1.8 = 7.2\text{m}.$

(iii) (b)  $\frac{\text{Height of flag}}{\text{Shadow length}} = \frac{\text{Height of tree}}{\text{Shadow length}}, \frac{6}{15} = \frac{\text{Height of tree}}{60}$   
 $\therefore \text{Height of tree} = \frac{360}{15} = 24\text{ m}$

2.

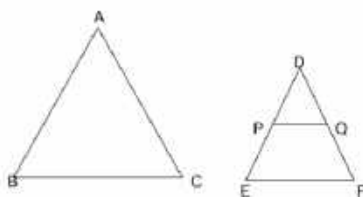

Triangle is a very popular shape used in interior designing. The picture given above shows a cabinet designed by a famous interior designer.

Here the largest triangle is represented by  $\triangle ABC$  and smallest one with shelf is represented by  $\triangle DEF$ .  $PQ$  is parallel to  $EF$ .

(i) Show that  $\triangle DPQ \sim \triangle DEF$ .

(ii) If  $DP = 50$  cm and  $PE = 70$  cm then find  $\frac{PQ}{EF}$ .

(iii) (a) If  $2AB = 5DE$  and  $\triangle ABC \sim \triangle DEF$  then show that the ratio of perimeters of  $\triangle ABC$  to that of  $\triangle DEF$  is 1:1.

(iii) (b) If  $AM$  and  $DN$  are medians of triangles  $ABC$  and  $DEF$  respectively then prove that  $\triangle ABM \sim \triangle DEN$ .

Ans. (i)  $\angle DPQ = \angle DEF$   $\angle PDQ = \angle EDF$  Therefore  $\triangle DPQ \sim \triangle DEF$

(ii)  $DE = 50 + 70 = 120$  cm

$$\frac{DP}{DE} = \frac{PQ}{EF} \Rightarrow \frac{50}{120} = \frac{PQ}{120}$$

(iii) (a)  $\frac{AB}{DE} = \frac{5}{2} = \frac{BC}{EF} = \frac{AC}{DF} \rightarrow AB = \frac{5}{2}DE$

$$\frac{\text{Perimeter of } \triangle ABC}{\text{Perimeter of } \triangle DEF} = \frac{5(DE + EF + FD)}{2(DE + EF + FD)} = \frac{5}{2}$$

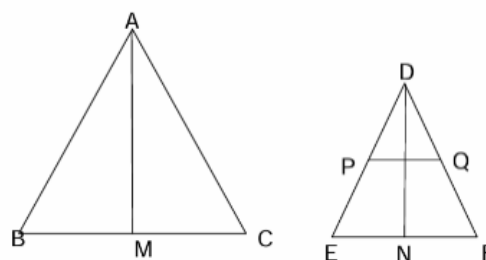

(iii) (b)  $\frac{AB}{DE} = \frac{BC}{EF} = \frac{\frac{1}{2}BC}{\frac{1}{2}EF} = \frac{BM}{EN}$

Also  $\angle B = \angle E$  Therefore  $\triangle ABM \sim \triangle DEN$ .

3. A student sees a flagpole and wants to find its height. He uses a 1-meter stick placed vertically on the ground. At a certain time of day, the stick casts a shadow of 0.4 meters and the flagpole casts a shadow of 2.8 meters.

(i) What is the ratio of the height of the stick to its shadow?

(ii) Which triangles are considered similar here?

iii(a). What is the height of the flagpole?

(OR)

iii(b). If the stick's shadow was 0.5 m and the pole's shadow was 3.5 m, what would be the new height of the flagpole?

Ans : (i) 1 : 0.4

(ii) Triangle formed by the stick and its shadow, and the triangle formed by the flagpole and its shadow.

(iii) (a) Using similar triangles:

$$\frac{1}{0.4} = \frac{h}{2.8} \Rightarrow h = \frac{1 \times 2.8}{0.4} = 7 \text{ meters}$$

(OR)

(iii) b.  $\frac{1}{0.5} = \frac{h}{3.5} \Rightarrow h = \frac{1 \times 3.5}{0.5} = 7 \text{ meters}.$



# CHAPTER – 7 COORDINATE GEOMETRY MIND MAPPING

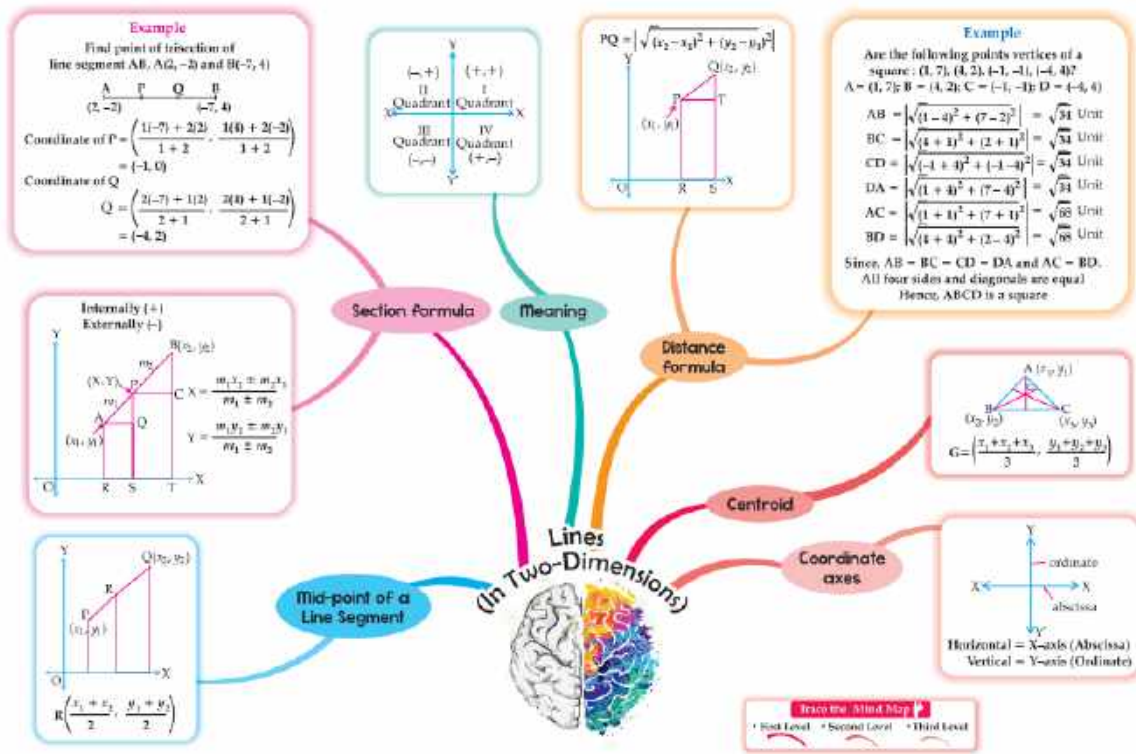

## GIST OF THE CHAPTER

1. Cartesian Coordinate system: two axes x axis (horizontal) and y axis (vertical)  
Intersection point is called as origin (0, 0)
2. Quadrants: Coordinate plane is divided into four quadrants.
3. Distance formula
4. Section formula and mid-point formula.

## DEFINITION

1. Coordinate Geometry: The study of geometry using the coordinate system.
2. Cartesian System: A plane divided into four quadrants by x axis and y axis.
3. Origin: The point where x axis and y axis intersect (0, 0)
4. Abscissa: The x-coordinate of a point.
5. Ordinate: The y-coordinate of a point.
6. Quadrant: The four regions of Cartesian plane. Quadrants: I (+,+), II (-, +), III (-, -), IV (+, -)

## FORMULA

1. Distance formula: To find the distance between two points A (x<sub>1</sub>, y<sub>1</sub>) and B(x<sub>2</sub>, y<sub>2</sub>):  
Distance (AB) =  $\sqrt{(x_2 - x_1)^2 + (y_2 - y_1)^2}$
2. Section formula: To find the coordinate of point P(x,y) that divides the line joining A (x<sub>1</sub>,y<sub>1</sub>) and B(x<sub>2</sub>,y<sub>2</sub>) in the ratio m<sub>1</sub>:m<sub>2</sub>  
$$P(x,y) = \left(\frac{m_1x_2 + m_2x_1}{m_1 + m_2}, \frac{m_1y_2 + m_2y_1}{m_1 + m_2}\right)$$
3. Midpoint formula: When m<sub>1</sub> = m<sub>2</sub>, The point divides the segment equally  
Midpoint:  $\left(\frac{x_1 + x_2}{2}, \frac{y_1 + y_2}{2}\right)$

## MULTIPLE CHOICE QUESTIONS (1 MARK QUESTIONS)

1. Coordinates of origin are:  
(a) (1, 0)                      (b) (0, 1)                      (c) (0, 0)                      (d) (1, 1)

**Ans.** (c) (0, 0)

2. Which point lies on the y-axis?

- (a) (0, 3)            (b) (3, 0)            (c) (1, 1)            (d) (-2, -2)

**Ans.** (a) (0, 3)

3. Which point lies in the fourth quadrant?

- (a) (3,4)            (b) (-3, -4)            (c) (3, -4)            (d) (-3, 4)

**Ans.** (c) (3, -4)

4. Mid point of line joining (2, 4) and (6, 8) is:

- (a) (4,6)            (b) (3,6)            (c) (5,7)            (d) (6, 8)

**Ans.** (a) (4,6)

5. The distance between the points P (0, 2) and Q (6, 0) is

- (a)  $4\sqrt{10}$             (b)  $2\sqrt{10}$             (c)  $\sqrt{10}$             (d) 20

**Ans.** (b)  $2\sqrt{10}$

6. What is y-coordinate of the mid-point (3,7) and (5,9)?

- (a) 7            (b) 8            (c) 6            (d) 9

**Ans.** (b) 8

7. Find the length of the diagonal of a rectangle with vertices A (1, 2) B (1,5) C(6,5) D (6,2):

- (a)  $\sqrt{34}$             (b) 5            (c)  $\sqrt{52}$             (d) 50

**Ans.** (a)  $\sqrt{34}$

8. Which of the following points lies on x-axis?

- (a) (2,0)            (b) (0,2)            (c) (3,4)            (d) (-1, -1)

**Ans.** (a) (2,0)

9. Which point lies in the first quadrant?

- (a) (-3,4)            (b) (3, -4)            (c) (3,4)            (d) (-3,-4)

**Ans.** (c) (3,4)

10. Distance between points (1,2) and (4, 6) is:

- (a) 8            (b)  $\sqrt{13}$             (c)  $\sqrt{25}$             (d) 7

**Ans.** (c)  $\sqrt{25}$

### **ASSERTION -REASONING BASED QUESTIONS**

**Directions:** In the questions below, a statement of Assertion(A) is followed by a statement of Reason®. Choose the correct option.

- (a) Both Assertion and Reason are true and Reason is the correct explanation of Assertion.  
(b) Both Assertion and Reason are true but Reason (R) is not the correct explanation of Assertion.  
(c) Assertion is true but Reason is false.  
(d) Assertion is false but Reason is true.

1. **Assertion(A):** The point (0,4) lies on y axis.

**Reason( R):** The x-coordinate on the point on y-axis is zero.

**Ans.** (a)

2. **Assertion(A):** The value of y is 6, for which the distance between the points P(2,-3) and Q(10,y) is 10.

**Reason(R):** Distance between two given points A( $x_1, y_1$ ) and B( $x_2, y_2$ ) is given by

$$AB = \sqrt{(x_2 - x_1)^2 + (y_2 - y_1)^2}$$

**Ans.** (d)

3. **Assertion(A):** Mid -point of a line segment divides line in the ratio 1:1.

**Reason( R):** The ratio in which the point (-3,k) divides the line segment joining the points (-5,4) and (-2,3) is 1:2.

**Ans.** (c)

4. **Assertion(A):** The point which divides the line joining the points A(1,2) and B(-1,1) internally in the ratio 1:2 is  $(\frac{1}{3}, \frac{5}{3})$

**Reason(R):** The coordinates of the point P(x,y) which divides the line segment joining the points A(x<sub>1</sub>,y<sub>1</sub>) and B(x<sub>2</sub>,y<sub>2</sub>) in the ratio m<sub>1</sub>:m<sub>2</sub> is  $(\frac{m_1x_2 + m_2x_1}{m_1+m_2}, \frac{m_1y_2 + m_2y_1}{m_1+m_2})$

**Ans.** (a)

**5.Assertion(A) :** The point on the X-axis which is equidistant from the points A(-2,3) and B(5,4) is (2,0)

**Reason(R) :** The coordinates of the point P(x,y) which divides the line segment joining the points A(x<sub>1</sub>,y<sub>1</sub>) and B(x<sub>2</sub>,y<sub>2</sub>) in the ratio m<sub>1</sub>:m<sub>2</sub> is  $(\frac{m_1x_2 + m_2x_1}{m_1+m_2}, \frac{m_1y_2 + m_2y_1}{m_1+m_2})$

**Ans.** (b)

**6. Assertion(A) :** Ratio in which the line 3x + 4y = 7 divides the line segment joining the points (1,2) and (-2,1) is 3:5

**Reason(R) :** The coordinates of the point P(x,y) which divides the line segment joining the points A(x<sub>1</sub>,y<sub>1</sub>) and B(x<sub>2</sub>,y<sub>2</sub>) in the ratio m<sub>1</sub>:m<sub>2</sub> is  $(\frac{m_1x_2 + m_2x_1}{m_1+m_2}, \frac{m_1y_2 + m_2y_1}{m_1+m_2})$

**Ans.** (d)

**7. Assertion(A) :** C is the mid point of PQ, if P is (4,x), C is (y,-1) and Q is (-2,4), then x and y respectively are -6 and 1.

**Reason(R) :** The mid point of the line segment joining the points P(x<sub>1</sub>,y<sub>1</sub>) and Q(x<sub>2</sub>,y<sub>2</sub>) is  $(\frac{x_1+x_2}{2}, \frac{y_1+y_2}{2})$

**Ans.** (a)

**8. Assertion(A) :** The point (-1,6) divides the line segment joining the points (-3,10) and (6,-8) in the ratio 2:7 internally.

**Reason (R) :** Three points A,B and C are collinear if AB + BC = AC

**Ans.** (b)

**9. Assertion(A):** The possible value of x for which the distance between the points A(x,-1) and B(5,3) is 5 units are 2 and 8.

**Reason(R) :** Distance between two given points A(x<sub>1</sub>,y<sub>1</sub>) and B(x<sub>2</sub>,y<sub>2</sub>) is given by

$$AB = \sqrt{(x_2 - x_1)^2 + (y_2 - y_1)^2}$$

**Ans.** (a)

**10. Assertion(A) :** If the points A(4,3) and B(x,5) lies on a circle with center O(2,3) then value of x is 2.

**Reason(R) :** The mid point of the line segment joining the points P(x<sub>1</sub>,y<sub>1</sub>) and Q(x<sub>2</sub>,y<sub>2</sub>) is  $(\frac{x_1+x_2}{2}, \frac{y_1+y_2}{2})$

**Ans.** (b)

### **VERY SHORT ANSWER TYPE QUESTIONS (2 MARKS QUESTIONS)**

1. Find the distance of the point A(0,1) and B(6,-1)

**Ans.** Distance formula,  $AB = \sqrt{(x_2 - x_1)^2 + (y_2 - y_1)^2}$

$$d = \sqrt{[(6 - 0)^2 + (-1 - 1)^2]} = \sqrt{[36 + 4]} = \sqrt{40} = 2\sqrt{10} \text{ units.}$$

2. Find the point on y axis which is equidistant from the point (5,-2) and (-3,2).

**Ans.** PA=PB, PA<sup>2</sup>=PB<sup>2</sup>

$$(5-0)^2 + (-2-b)^2 = (-3-0)^2 + (2-b)^2 = 29+4b+b^2 = 13 + b^2 - 4b$$

$$b = -2 \quad \text{Required point } (0,-2)$$

3. Find a relation between x and y such that the point (x, y) is equidistant from the points (7,1) and (3,5).

**Ans.** Let P(x, y) be equidistant from the points A(7, 1) and B(3, 5).

AP = BP, AP<sup>2</sup> = BP<sup>2</sup>, Using distance formula, Distance (AB) =  $\sqrt{(x_2 - x_1)^2 + (y_2 - y_1)^2}$

$$(x - 7)^2 + (y - 1)^2 = (x - 3)^2 + (y - 5)^2 = x^2 - 6x + 9 + y^2 - 10y + 2$$

$$x - y = 2$$

4. Find the ratio in which the line segment joining the points (-3,10) and (6,-8) is divided by (-1,6).

**Ans.** Let the ratio be k : 1 by section formula,  $P(x,y) = (\frac{Kx_2 + x_1}{K+1}, \frac{Ky_2 + y_1}{K+1})$

$$-1 = \frac{6k-3}{k+1}, 7k = 2, k = \frac{2}{7}$$

hence, ratio is 2:7

5. Find the coordinates of point A, where AB is the diameter of a circle whose center is (2,-3) and B is (1,4).

**Ans.** Let the coordinates of point A be (x, y). , Mid-point of AB is (2, - 3), Coordinate of B = (1, 4)  
 $(2, -3) = \left(\frac{x+1}{2}, \frac{y+4}{2}\right)$

$$x + 1 = 4 \text{ and } y + 4 = -6, x = 3 \text{ and } y = -10$$

6. Find the distance of the point P (2, 3) from the x-axis.

**Ans.** (x, y) = (2, 3) is a point on the Cartesian plane in the first quadrant.

x = Perpendicular distance from y-axis, y = Perpendicular distance from x-axis

Therefore, the distance from x-axis y = 3 units

7. Find the value of k, if the point P(2, 4) is equidistant from the points A(5, k) and B(k, 7).

**Ans.** PA=PB,  $PA^2 = PB^2$  ... [Squaring both sides

$$(5 - 2)^2 + (k - 4)^2 = (k - 2)^2 + (7 - 4)^2$$

$$(k - 4 + k - 2)(k - 4 - k + 2) = 0, 2k - 6 = 0, k = 3$$

8. Find the distance of the point A(5,1) and B(9,-1)

**Ans.** using distance formula, Distance (AB) =  $\sqrt{(x_2 - x_1)^2 + (y_2 - y_1)^2}$

$$d = \sqrt{[(9 - 5)^2 + (-1 - 1)^2]} = \sqrt{[16 + 4]} = \sqrt{20} = 2\sqrt{5} \text{ units.}$$

9. Find the point on y axis which is equidistant from the point (6,-2) and (-6, 2).

**Ans.** Let the required point on y-axis be P(0,b), PA=PB,  $PA^2 = PB^2$

$$(6-0)^2 + (-2-b)^2 = (-6-0)^2 + (2-b)^2, b = 0, \text{ Required point is } (0,0)$$

10. Find the distance of the point P(-6,8) from the origin is

**Ans.** using distance formula, Distance (AB) =  $\sqrt{(x_2 - x_1)^2 + (y_2 - y_1)^2}$

$$d = \sqrt{[(-6-0)^2 + (8-0)^2]} = \sqrt{[36 + 64]} = \sqrt{100} = 10 \text{ Units.}$$

Hence, Distance of OP is 10 units.

### SHORT ANSWER TYPE QUESTIONS (3 MARKS QUESTIONS)

1. Find the ratio in which y axis divides the line segment joining the points A(5,-6) and B(-1,-4).

**Ans.** By using section formula,  $P(x,y) = \left(\frac{kx_2+x_1}{k+1}, \frac{ky_2+y_1}{k+1}\right)$ , Coordinates of P is  $\left(\frac{-k+5}{k+1}, \frac{-4k-6}{k+1}\right)$ ,

P lies on y-axis  $\therefore \frac{-k+5}{k+1} = 0$  i.e. k=5

$\therefore$  y-axis divide AB in ratio 5:1

2. If the point C(-1, 2) divides internally the line segment joining A (2, 5) and B (x, y) in the ratio 3:4, find the coordinates of B.

**Ans.** Using section formula,  $C(-1, 2) = \left[\frac{m_1x_2 + m_2x_1}{m_1+m_2}, \frac{m_1y_2 + m_2y_1}{m_1+m_2}\right] = \left[\frac{3x + 8}{3+4}, \frac{3y+20}{3+4}\right]$

By equating,  $\frac{3x+8}{7} = -1, 3x = -15, x = -5, \frac{3y+20}{7} = 2, 3y = -6, y = -2$

coordinates of B (x, y) = (-5, -2).

3. Find the point P on x-axis equidistant from the points A(-1,0) and B(5,0) is

**Ans.** Let P(x, 0) be equidistant PA=PB

$$\sqrt{(x + 1)^2 + (0 - 0)^2} = \sqrt{(x - 5)^2 + (0 - 0)^2} \Rightarrow x^2 + 1 + 2x = x^2 + 25 - 10x$$

$$12x = 24, x = 2 \therefore \text{Point P}(2,0)$$

4. If the distances of P(x,y) from A (5,1) and B (-1,5) are equal, then prove that 3x=2y.

**Ans.** Using distance formula, Distance (AB) =  $\sqrt{(x_2 - x_1)^2 + (y_2 - y_1)^2}$

$$PA=PB \Rightarrow PA^2 = PB^2 \Rightarrow (x-5)^2 + (y-1)^2 = (x+1)^2 + (y-5)^2$$

$$12x = 8y \Rightarrow 3x = 2y$$

5. Find the distance of the point A(5,9) and B(5,-7)

**Ans.** Using distance formula, Distance (AB) =  $\sqrt{(x_2 - x_1)^2 + (y_2 - y_1)^2}$

$$d = \sqrt{[(5 - 5)^2 + (-7 - 9)^2]} = \sqrt{256} = 16 \text{ units.}$$

6. Find the coordinates of point, which divides line joining of (-2,2) and (2,8) in ratio 1:3

**Ans.** By using section formula,  $P(x,y) = \left(\frac{m_1x_2+m_2x_1}{m_1+m_2}, \frac{m_1y_2+m_2y_1}{m_1+m_2}\right)$

Thus coordinates are  $(-1, \frac{7}{2})$

7. What is ratio in which the line segment joining (2,-3) and (3,4) is divided by x-axis?

**Ans.** Let ratio be k:1 using section formula we get ratio 1:2.

8. If the distance between the points (2,-2) and (-1,x) is 5, then one of the values of x is

**Ans.** using distance formula, Distance =  $\sqrt{(x_2 - x_1)^2 + (y_2 - y_1)^2}$

$$\sqrt{(2+1)^2 + (-2-x)^2} = 5$$

$$x = 2, -6$$

9. Find a relation between x and y such that the point (x, y) is equidistant from the points (5, 1) and (6,5)

**Ans:** Let P(x, y) be equidistant from the points A(5, 1) and B(6, 5).

AP = BP  $\Rightarrow AP^2 = BP^2$ , Using distance formula, Distance (AB) =  $\sqrt{(x_2 - x_1)^2 + (y_2 - y_1)^2}$

$$(x-5)^2 + (y-1)^2 = (x-6)^2 + (y-5)^2 \Rightarrow \text{relation } 2x+8y=35$$

10. Find the distance of the point P(-7,4) from the origin is

**Ans :** using distance formula, Distance (OP) =  $\sqrt{(x_2 - x_1)^2 + (y_2 - y_1)^2}$

$$d = \sqrt{[(-7-0)^2 + (4-0)^2]} = \sqrt{[49 + 16]} = \sqrt{65} \text{ units.}$$

### LONG ANSWER TYPE QUESTIONS (5 MARK QUESTIONS)

1. Find the ratio in which y-axis divides the line segment joining the points A (5, -6), and B(-1, -4). Also find the coordinates of the point of division.

**Ans.** Using the formula we get ratio 5:1 and the co-ordinates of the point is  $(0, -\frac{13}{3})$ .

2. If A(4, 3), B(-1, y) and C(3, 4) are the vertices of a right triangle ABC, right-angled at A, then find the value of y.

**Ans.** By using Pythagoras theorem and distance formula we get  $y = -2$ .

3. An equilateral triangle has one vertex at (3, 4) and another at (-2, 3). Find the co-ordinates of the third vertex.

**Ans.** Using distance formula the coordinates of the third vertex of an equilateral triangle is  $(\frac{1+\sqrt{3}}{2}, \frac{7-5\sqrt{3}}{2})$  or  $(\frac{1-\sqrt{3}}{2}, \frac{7+5\sqrt{3}}{2})$

4. The three vertices of a parallelogram ABCD are A (3, -4), B (-1, -3) and C (-6, 2). Find the coordinates of vertex D.

**Ans.** The coordinates of vertex D is (-2,1).

5. The base QR of an equilateral triangle PQR lies on x-axis. The co-ordinates of point Q are (-4, 0) and the origin is the mid-point of the base. Find the co-ordinates of the point P and R.

**Ans.** The coordinates of point P is  $(0, 4\sqrt{3})$  or  $(0, -4\sqrt{3})$  and R is (4,0)

### CASE BASED QUESTIONS(4 MARK QUESTIONS)

1. In a classroom four friends are seated at point A, B, C and D as shown in figure Champa and Chameli Walk into the class and after observing for a few minutes Champa asks some questions to Chameli,

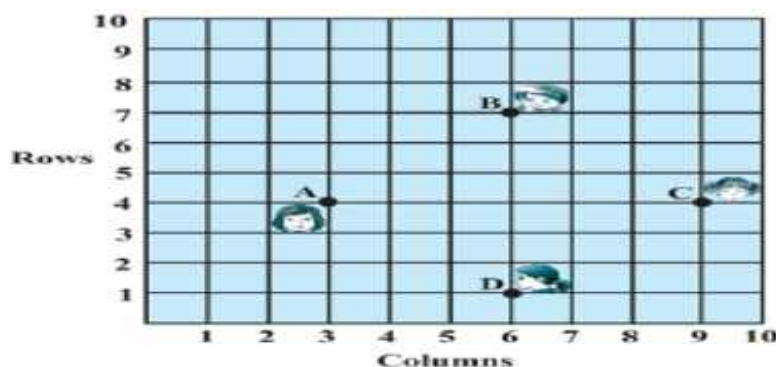

(i) Find the distance between the point A and B.

**Ans.**  $AB = \sqrt{(6 - 3)^2 + (7 - 4)^2} = \sqrt{9 + 9} = 3\sqrt{2}$

(ii) Find. Diagonal AC

**Ans.** Diagonal AC =  $\sqrt{(3 - 9)^2 + (4 - 4)^2} = \sqrt{36} = 6$

(iii) Are both the diagonals are equal?

**Ans.** Yes

(i)“Do you think ABCD is a square?”

**Ans.** Yes

2.The class X students of a school in Rajinder Nagar have been allotted a rectangular plot of land for their gardening activity. Sapling of mango are planted on the boundary at the distance of 1m from each other. There is a triangular grassy lawn in the plot as shown in figure.

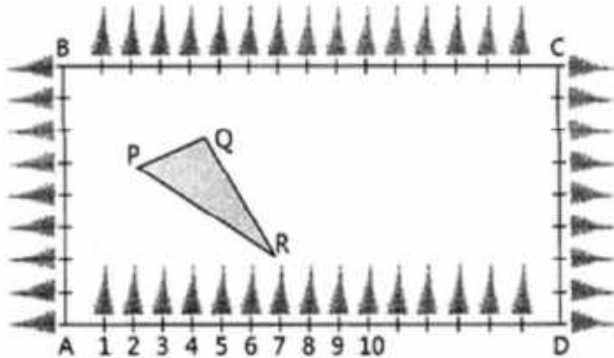

Based on the above figure, answer the following questions

(i). Taking A as origin, find the coordinates of vertices of the triangle.

**Ans.** (1,5) (4,6) (7,2)

(ii). Find the perimeter of triangle PQR?

**Ans.**  $15 + 3\sqrt{5}$  units

3.Find the Coordinates of the point M on PR such that PM:MR = 2:1

**Ans.** (5,3)

4. What will be the coordinates of the vertices of triangle PQR if C is origin?

**Ans.** (15,3) (12,2) (9,6)

3.A student of class X located points A, B, C, D, E, F, and G on a graph sheet with given coordinates.

Observe his work and answer the questions:

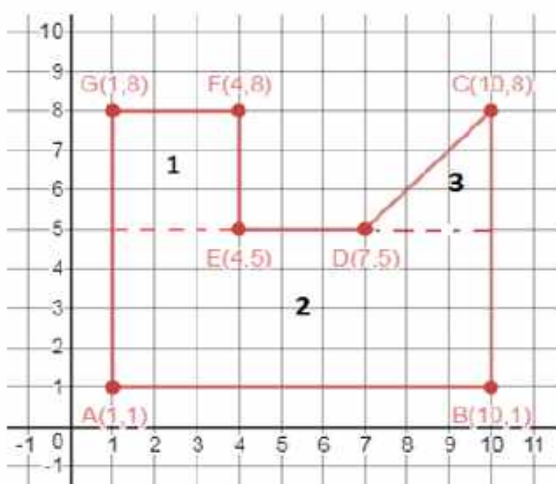

(i) Find the length of line segment CD.

**Ans.**  $CD = \sqrt{3^2 + 3^2} = 3\sqrt{2}$

(ii) Find the midpoint of line segment AC

**Ans.** Mid-point of AC =  $(\frac{1+10}{2}, \frac{1+8}{2}) = (5.5, 4.5)$

(iii) The point on y-axis which is equidistance from C and E.

**Ans.** Applying distance formula we get point on Y axis as (0,20.5)

(iv) Find the coordinates of the point which divides the line segment GE in the ratio 1:2

**Ans.** Using section formula we get point as (2,7)

4. The following graph shows the number of persons in family in a locality. Observe the graph and answer the question given

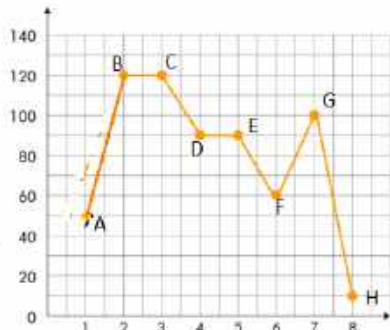

(i)The length of line segment CD is

(ii)The midpoint of the line segment joining F(6,60) and G(7,100)

(iii)Find the coordinates of the point which divides joining of G and H in the ratio 2:3

(iv)Find the point on x-axis which is equidistance from D and E.

**Ans.** (i)  $\sqrt{901}$ , (ii).(6.5,80) (iii).(7.4,64), (iv). (4.5,0)

5.Observe the following diagram drawn on a graph sheet and answer the question given.

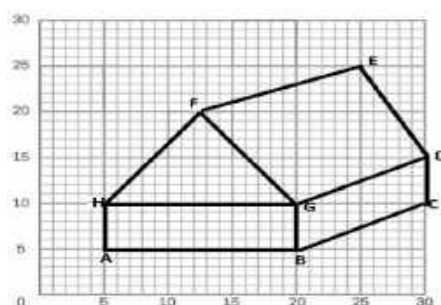

(i)Find the length of side BC of the quadrilateral BCDG. The coordinates B(20,5) and C(30,10).

(ii)Find the midpoint of diagonal BD of the quadrilateral BCDG.

(iii)Find the coordinate of the point on y-axis equidistant from B and D

(iv)Find the coordinates of the point which divides line segment GE in the ratio 2:3

**Ans.** (i)  $5\sqrt{5}$  (ii)(25,10) (iii)(0,35) (iv)(22,16)

### HIGHER ORDER THINKING SKILLS

1. If A (-2, 4), B (0, 0) and C (4, 2) are the vertices of triangle ABC, then find the length of the median through the vertex A.

**Ans.** Using mid-point formula we get mid-point (2,1). The length of the median through vertex A is 5 units.

# CHAPTER 8

## INTRODUCTION TO TRIGONOMETRY

### MIND MAP

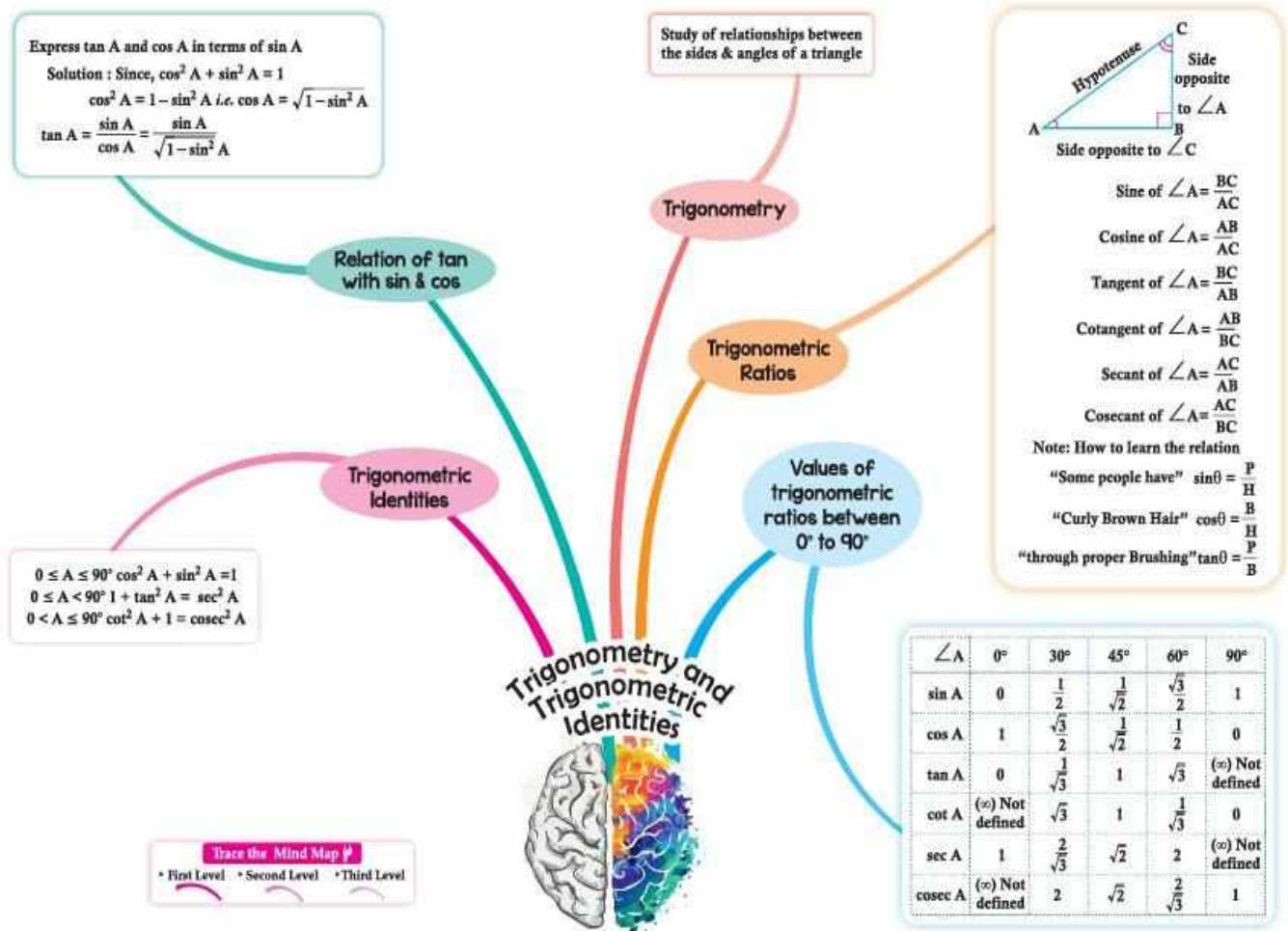

### GIST OF THE CHAPTER

1. TRIGONOMETRY is the branch of mathematics that deals with the relationship between the angles and sides of a right angled triangle.
2. Trigonometric ratios-Sine(Sin),Cosine(Cos),Tangent(Tan),Co-secant(Cosec),Secant(Sec), Co-tangent (Cot)
3. Trigonometric ratios of specific angles 0°, 30°, 45°, 60°, 90°
4. Trigonometric identities

### FORMULA

$$\sin \theta = \frac{\text{opposite side}}{\text{hypotenuse}}$$

$$\cos \theta = \frac{\text{adjacent side}}{\text{hypotenuse}}$$

$$\tan \theta = \frac{\text{opposite side}}{\text{adjacent side}}$$

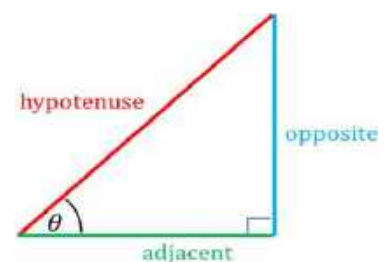

$$\operatorname{Cosec} \theta = \frac{\text{hypotenuse}}{\text{opposite side}} = \frac{1}{\sin \theta}$$

$$\operatorname{Sec} \theta = \frac{\text{hypotenuse}}{\text{adjacent side}} = \frac{1}{\cos \theta}$$

$$\operatorname{Cot} \theta = \frac{\text{adjacent side}}{\text{opposite side}} = \frac{\cos \theta}{\sin \theta}$$

### TRIGONOMETRIC RATIOS

angle $\theta$ ratio	$0^\circ$	$30^\circ$	$45^\circ$	$60^\circ$	$90^\circ$
$\sin \theta$	0	$\frac{1}{2}$	$\frac{\sqrt{2}}{2}$	$\frac{\sqrt{3}}{2}$	1
$\cos \theta$	1	$\frac{\sqrt{3}}{2}$	$\frac{\sqrt{2}}{2}$	$\frac{1}{2}$	0
$\tan \theta$	0	$\frac{\sqrt{3}}{3}$	1	$\sqrt{3}$	undefined
$\operatorname{cosec} \theta$	undefined	2	$\sqrt{2}$	$\frac{2\sqrt{3}}{3}$	1
$\operatorname{sec} \theta$	1	$\frac{2\sqrt{3}}{3}$	$\sqrt{2}$	2	undefined
$\operatorname{cot} \theta$	undefined	$\sqrt{3}$	1	$\frac{\sqrt{3}}{3}$	0

### TRIGONOMETRIC IDENTITIES

- $\sin^2 A + \cos^2 A = 1$
- $\sec^2 A = 1 + \tan^2 A$
- $\operatorname{cosec}^2 A = 1 + \cot^2 A$

### MULTIPLE CHOICE QUESTIONS (1 MARK QUESTIONS)

1. In a right triangle ABC, the right angle is at B. What is the length of the missing side in the figure?

- (a) 25 cm (b) 12cm  
(c) 7cm (d) 5cm

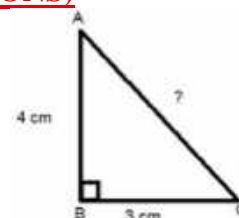

**Ans:** (d)5cm

1. Given that  $\sin \alpha = \frac{1}{2}$  and  $\cos \beta = \frac{1}{2}$ , then the value of  $(\alpha + \beta)$  is

- (a)  $0^\circ$  (b)  $30^\circ$  (c)  $60^\circ$  (d)  $90^\circ$

**Ans** (d)  $90^\circ$

2. If  $\sqrt{2} \sin (60^\circ - \alpha) = 1$  then  $\alpha$  is

- (a)  $45^\circ$  (b)  $15^\circ$  (c)  $60^\circ$  (d)  $30^\circ$

**Ans** : (b)  $15^\circ$

3. If  $\cos (40^\circ + A) = \sin 30^\circ$ , then value of A is

- (a)  $30^\circ$  (b)  $40^\circ$  (c)  $60^\circ$  (d)  $20^\circ$

**Ans** (d)  $20^\circ$

4. If  $\operatorname{cosec} \theta - \cot \theta = \frac{1}{3}$ , the value of  $(\operatorname{cosec} \theta + \cot \theta)$  is

- (a) 1 (b) 2 (c) 3 (d) 4

**Ans** : (c)3

5.  $\frac{1+\tan^2 A}{1+\cot^2 A}$  is equal to

- (a)  $\sec^2 A$  (b) -1 (c)  $\cot^2 A$  (d)  $\tan^2 A$

**Ans** (d)  $\tan^2 A$

6. If  $\cos A + \cos^2 A = 1$ , then  $\sin^2 A + \sin^4 A$  is equal to

- (a) -1 (b) 0 (c) 1 (d) None of these

Ans (c) 1

7. If  $\sin 2A = \frac{1}{2} \tan^2 45^\circ$  where A is an acute angle, then the value of A is

- (a)  $60^\circ$                       (b)  $45^\circ$                       (c)  $30^\circ$                       (d)  $15^\circ$

Ans (d)  $15^\circ$

8. If  $A + B = 90^\circ$ ,  $\cot B = \frac{3}{4}$  then  $\tan A$  is equal to:

- (a)  $\frac{5}{3}$                       (b)  $\frac{1}{3}$                       (c)  $\frac{3}{4}$                       (d)  $\frac{1}{4}$

Ans (c)  $\frac{3}{4}$

9. The maximum value of  $\frac{1}{\operatorname{cosec} \alpha}$  is

- (a) 0                      (b) 1                      (c)  $\frac{\sqrt{3}}{2}$                       (d)  $\frac{1}{\sqrt{2}}$

Ans (b) 1

### ASSERTION REASON BASED QUESTIONS

**DIRECTION:** In the following questions, a statement of **Assertion (A)** is followed by a statement of **Reason (R)**. Choose the correct option

(a) Both assertion (A) and reason (R) are true and reason (R) is the correct explanation of assertion (A)

(b) Both assertion (A) and reason (R) are true and reason (R) is not the correct explanation of assertion (A)

(c) Assertion (A) is true but reason (R) is false.

(d) Assertion (A) is false but reason (R) is true.

1. **Assertion (A):** In a right-angled triangle, if  $\tan A = 1$ , then  $2 \sin A \cdot \cos A = 1$ .

**Reason (R):**  $\tan 45^\circ = 1$  and  $\sin 45^\circ = \cos 45^\circ = \frac{1}{\sqrt{2}}$

Ans:(a)

2. **Assertion (A):**  $\sin(A + B) = \sin A + \sin B$ .

**Reason (R):** For any angle  $\theta$ ,  $1 + \tan^2 \theta = \sec^2 \theta$ .

Ans: (d)

3. **Assertion (A):** In a right-angled triangle, if  $\tan A = \frac{12}{5}$ , then  $\sec A = \frac{13}{5}$

**Reason (R):**  $\cot A$  is the product of cotangent and angle A.

Answer: (c)

4. **Assertion (A):**  $\sin^2 A + \cos^2 A = 1$

**Reason (R):**  $(\sin A + \cos A)^2 = 1$  for any angle A.

Ans: (c)

5. **Assertion (A):** The value of  $\sin \theta = \frac{4}{3}$  is not possible.

**Reason (R):** 3, 4, 5 form a Pythagorean triplet.

Ans: (b)

6. **Assertion (A):** In a right-angled triangle, if  $\tan A = 1$ , then  $2 \sin A \cdot \cos A = 1$ .

**Reason (R):**  $\sec A$  is the abbreviation used for cosecant of an angle A.

Ans: (c)

7. **Assertion (A):** The value of each trigonometric ratio of an angle does not vary with the lengths of the sides of the triangle if the angle remains the same.

**Reason (R):** In a right-angled triangle ABC,  $\sin \theta = \frac{BC}{AC} < 1$  and  $\cos \theta = \frac{AB}{AC} < 1$  as the hypotenuse is the longest side.

Ans: (c)

8. **Assertion (A):**  $\cos^4 A - \sin^4 A = 2 \cos^2 A - 1$ .

**Reason (R):** The value of  $\cos \theta$  decreases as  $\theta$  increases for  $0^\circ \leq \theta \leq 90^\circ$ .

Ans: (b)

9. **Assertion (A):** If  $x \sin^3 \theta + y \cos^3 \theta = \sin \theta \cos \theta$  and  $x \sin \theta = y \cos \theta$ , then  $x^2 + y^2 = 1$ .

**Reason (R):** For any angle  $\theta$ ,  $\sin^2 \theta + \cos^2 \theta = 1$ .

Ans: (a)

10. **Assertion (A):** In a right-angled triangle, if  $\tan A = \frac{12}{5}$ , then  $\sec A = \frac{13}{5}$ .

**Reason (R):**  $\cot A$  is the product of cotangent and angle  $A$ .

Ans: (c)

### VERY SHORT ANSWER TYPE QUESTIONS (2 MARK QUESTIONS)

1. If  $\tan \theta + \cot \theta = 5$ , find the value of  $\tan^2 \theta + \cot^2 \theta$ .

Solution:  $\tan \theta + \cot \theta = 5 \dots$  [Given]

$$\tan^2 \theta + \cot^2 \theta + 2 \tan \theta \cot \theta = 25 \dots \text{ [Squaring both sides]}$$

$$\tan^2 \theta + \cot^2 \theta + 2 = 25$$

$$\therefore \tan^2 \theta + \cot^2 \theta = 23$$

2. If  $\tan \alpha = \sqrt{3}$  and  $\tan \beta = \frac{1}{\sqrt{3}}$ ,  $0 < \alpha, \beta < 90^\circ$ , find the value of  $\cot(\alpha + \beta)$ .

Solution:  $\tan \alpha = \sqrt{3} = \tan 60^\circ \dots$  (i)

$$\tan \beta = \frac{1}{\sqrt{3}} = \tan 30^\circ \dots$$
 (ii)

Solving (i) & (ii),  $\alpha = 60^\circ$  and  $\beta = 30^\circ$

$$\therefore \cot(\alpha + \beta) = \cot(60^\circ + 30^\circ) = \cot 90^\circ = 0$$

3. If  $\operatorname{cosec} \theta = \frac{5}{4}$ , find the value of  $\cot \theta$ .

Solution: We know that,  $\cot^2 \theta = \operatorname{cosec}^2 \theta - 1$

$$= \left[\frac{5}{4}\right]^2 - 1 \Rightarrow \frac{25}{16} - 1 \Rightarrow \frac{25-16}{16}$$

$$\cot^2 \theta = \frac{9}{16}$$

$$\therefore \cot \theta = \frac{3}{4}$$

4. If  $\theta = 45^\circ$ , then what is the value of  $2 \sec^2 \theta + 3 \operatorname{cosec}^2 \theta$ ?

$$\begin{aligned} \text{Solution: } 2 \sec^2 \theta + 3 \operatorname{cosec}^2 \theta &= 2 \sec^2 45^\circ + 3 \operatorname{cosec}^2 45^\circ \\ &= 2(\sqrt{2})^2 + 3(\sqrt{2})^2 = 4 + 6 = 10 \end{aligned}$$

5. If in a right angled  $\triangle ABC$ ,  $\tan B = \frac{12}{5}$ , then find  $\sin B$ .

Solution:  $\tan B = \frac{12}{5}$ , So  $\cot B = \frac{5}{12}$

$$\operatorname{cosec}^2 B = 1 + \cot^2 B$$

$$= 1 + \left(\frac{5}{12}\right)^2$$

$$= 1 + \frac{25}{144} = \frac{169}{144}$$

$$\operatorname{cosec} B = \frac{13}{12} \therefore \sin B = \frac{12}{13}$$

6. If  $\triangle ABC$  is right angled at  $B$ , What is the value of  $\sin(A + C)$ ?

Solution:  $\angle B = 90^\circ \dots$  [Given  $\angle A + \angle C + 90^\circ = 180^\circ$ ]

$$\angle A + \angle C = 90^\circ$$

$$\therefore \sin(A + C) = \sin 90^\circ = 1$$

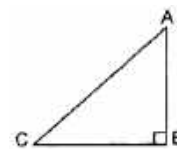

7. If  $x = a \cos \theta - b \sin \theta$  and  $y = a \sin \theta + b \cos \theta$ , then prove that  $a^2 + b^2 = x^2 + y^2$ .

Solution:

$$\text{R.H.S.} = x^2 + y^2$$

$$= (a \cos \theta - b \sin \theta)^2 + (a \sin \theta + b \cos \theta)^2$$

$$= a^2 \cos^2 \theta + b^2 \sin^2 \theta - 2ab \cos \theta \sin \theta + a^2 \sin^2 \theta + b^2 \cos^2 \theta + 2ab \sin \theta \cos \theta$$

$$= a^2(\cos^2 \theta + \sin^2 \theta) + b^2(\sin^2 \theta + \cos^2 \theta)$$

$$= a^2 + b^2 = \text{L.H.S}$$

8. Given  $2\cos 3\theta = \sqrt{3}$ , find the value of  $\theta$ .

Solution:  $2\cos 3\theta = \sqrt{3} \dots$  [Given]  
 $\cos 3\theta = \frac{\sqrt{3}}{2} \Rightarrow \cos 3\theta = \cos 30^\circ$   
 $3\theta = 30^\circ \therefore \theta = 10^\circ$

9. If  $\tan \theta + \cot \theta = 5$ , find the value of  $\tan^2\theta + \cot^2\theta$ .

Solution:  $\tan \theta + \cot \theta = 5 \dots$  [Given]  
 $\tan^2\theta + \cot^2\theta + 2 \tan \theta \cot \theta = 25 \dots$  (Squaring both sides)  
 $\tan^2\theta + \cot^2\theta + 2 = 25$   
 $\therefore \tan^2\theta + \cot^2\theta = 23$

10. If  $\sqrt{3} \sin \theta = \cos \theta$ , find the value of  $\frac{3\cos^2 \theta + 2\cos \theta}{3\cos \theta + 2}$ .

Solution:  $\sqrt{3} \sin \theta = \cos \theta \dots$  [Given]  
 $\Rightarrow \frac{\sin \theta}{\cos \theta} = \frac{1}{\sqrt{3}}$   
 $\Rightarrow \tan \theta = \tan 30^\circ \Rightarrow \theta = 30^\circ$

Now,  $\frac{3\cos^2 \theta + 2\cos \theta}{3\cos \theta + 2} = \frac{\cos \theta (3\cos \theta + 2)}{3\cos \theta + 2} = \cos \theta$

$\therefore \cos 30^\circ = \frac{\sqrt{3}}{2}$

### SHORT ANSWER TYPE QUESTIONS (3 MARKS QUESTIONS)

1. If  $x = p \sec \theta + q \tan \theta$  and  $y = p \tan \theta + q \sec \theta$ , then prove that  $x^2 - y^2 = p^2 - q^2$ .

Solution:

L.H.S. =  $x^2 - y^2$   
 $= (p \sec \theta + q \tan \theta)^2 - (p \tan \theta + q \sec \theta)^2$   
 $= p^2 \sec^2 \theta + q^2 \tan^2 \theta + 2pq \sec^2 \theta \tan^2 \theta - (p^2 \tan^2 \theta + q^2 \sec^2 \theta + 2pq \sec \theta \tan \theta)$   
 $= p^2 \sec^2 \theta + 2 \tan^2 \theta + 2pq \sec \theta \tan \theta - p^2 \tan^2 \theta - q^2 \sec^2 \theta - 2pq \sec \theta \tan \theta$   
 $= p^2(\sec^2 \theta - \tan^2 \theta) - q^2(\sec^2 \theta - \tan^2 \theta) =$   
 $= p^2 - q^2 \dots [\sec^2 \theta - \tan^2 \theta = 1 = \text{R.H.S}]$

2. Prove the identity following:

$$\frac{\sin^3 \theta + \cos^3 \theta}{\sin \theta + \cos \theta} = 1 - \sin \theta \cos \theta$$

Solution:

LHS =  $\frac{\sin^3 \theta + \cos^3 \theta}{\sin \theta + \cos \theta}$   
 $= \frac{(\sin \theta + \cos \theta)(\sin^2 \theta + \cos^2 \theta - \sin \theta \cos \theta)}{\sin \theta + \cos \theta} \dots [\because a^3 + b^3 = (a+b)(a^2 + b^2 - ab)]$   
 $= 1 - \sin \theta \cos \theta = \text{RHS} \dots [\because \sin^2 \theta + \cos^2 \theta = 1]$

3. If  $5 \sin \theta = 4$ , prove that  $\frac{1}{\cos \theta} + \frac{1}{\cot \theta} = 3$

Solution: Given  $5 \sin \theta = 4$

$$\therefore \sin \theta = \frac{4}{5}$$

In rt  $\Delta ABC$ , Let  $BC = 4K$ ,  $AC = 5K$  and we know that  $AB^2 + BC^2 = AC^2$

$AB^2 + (4K)^2 = (5K)^2$   
 $AB^2 + 16K^2 = 25K^2$   
 $AB^2 = 25K^2 - 16K^2 = 9K^2$   
 $\therefore AB = 3K$

$$\cos \theta = \frac{3K}{5K} = \frac{3}{5}, \cot \theta = \frac{3}{4}$$

$$\text{LHS} = \frac{1}{\cos \theta} + \frac{1}{\cot \theta} = \frac{5}{3} + \frac{4}{3} = \frac{9}{3} = 3 = \text{RHS}$$

4. In figure,  $\Delta PQR$  right angled at  $Q$ ,  $PQ = 6$  cm and  $PR = 12$  cm. Determine  $\angle QPR$  and  $\angle PRQ$ .

Solution:

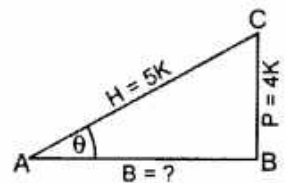

In rt.  $\Delta PQR$ ,  $PQ^2 + QR^2 = PR^2 \dots$  [By Pythagoras' theorem]

$$(6)^2 + QR^2 = (12)^2$$

$$QR^2 = 144 - 36$$

$$QR^2 = 108 \Rightarrow QR = \sqrt{36 \times 3} = 6\sqrt{3} \text{ cm}$$

$$\tan R = \frac{PQ}{QR} = \frac{6}{6\sqrt{3}} = \frac{1}{\sqrt{3}}$$

$$\tan R = \tan 30^\circ$$

$$R = 30^\circ$$

$$\therefore \angle PRQ = 30^\circ$$

$$\tan P = \frac{QR}{PQ} = \frac{6\sqrt{3}}{6} = \sqrt{3}$$

$$\tan P = \tan 60^\circ$$

$$P = 60^\circ$$

$$\therefore \angle QPR = 60^\circ$$

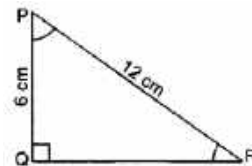

4. Simplify:  $\frac{1+\tan^2 A}{1+\cot^2 A}$

$$\text{Solution: } \frac{1+\tan^2 A}{1+\cot^2 A} = \frac{\sec^2 A}{\operatorname{cosec}^2 A} = \frac{\frac{1}{\cos^2 A}}{\frac{1}{\sin^2 A}} = \frac{1}{\cos^2 A} \times \frac{\sin^2 A}{1} = \tan^2 A$$

6. Prove that:  $\frac{\sin \theta - 2\sin^3 \theta}{2\cos^3 \theta - \cos \theta} = \tan \theta$

$$\text{Solution: LHS} = \frac{\sin \theta - 2\sin^3 \theta}{2\cos^3 \theta - \cos \theta} = \frac{\sin \theta (1 - 2\sin^2 \theta)}{\cos \theta (2\cos^2 \theta - 1)} \quad (\because \cos^2 \theta = 1 - \sin^2 \theta)$$

$$= \frac{\sin \theta (1 - 2\sin^2 \theta)}{\cos \theta [2(1 - \sin^2 \theta) - 1]} = \frac{\tan \theta (1 - 2\sin^2 \theta)}{(1 - 2\sin^2 \theta)} = \tan \theta = \text{RHS}$$

7. Prove that:  $\frac{\sin \theta - \cos \theta}{\sin \theta + \cos \theta} + \frac{\sin \theta + \cos \theta}{\sin \theta - \cos \theta} = \frac{2}{2\sin^2 \theta - 1}$

Solution :

$$\begin{aligned} \text{LHS} &= \frac{\sin \theta - \cos \theta}{\sin \theta + \cos \theta} + \frac{\sin \theta + \cos \theta}{\sin \theta - \cos \theta} \\ &= \frac{\sin \theta - \cos \theta}{\sin \theta + \cos \theta} + \frac{\sin \theta + \cos \theta}{\sin \theta - \cos \theta} \\ &= \frac{(\sin \theta - \cos \theta)^2 + (\sin \theta + \cos \theta)^2}{(\sin \theta + \cos \theta)(\sin \theta - \cos \theta)} = \frac{\sin^2 \theta + \cos^2 \theta - 2\sin \theta \cos \theta + \sin^2 \theta + \cos^2 \theta + 2\sin \theta \cos \theta}{\sin^2 \theta - \cos^2 \theta} \\ &= \frac{1+1}{2\sin^2 \theta - 1} = \frac{2}{2\sin^2 \theta - 1} = \text{RHS} \end{aligned}$$

8. If  $\tan \theta = \frac{a}{x}$ , find the value of  $\cos \theta$ .

$$\text{Solution: } \tan \theta = \frac{a}{x} \Rightarrow \frac{P}{B} = \frac{a}{x}$$

$$\therefore P = ak, B = xk$$

In rt  $\Delta ABC$ ,  $H^2 = P^2 + B^2$

$$= a^2 k^2 + x^2 k^2 = k^2 (a^2 + x^2)$$

$$\Rightarrow H = k (\sqrt{a^2 + x^2})$$

$$\therefore \cos \theta = \frac{B}{H} = \frac{xk}{k\sqrt{a^2 + x^2}} = \frac{x}{\sqrt{a^2 + x^2}}$$

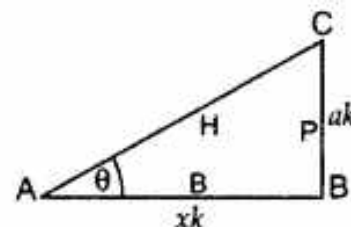

9. If  $\sin \theta = \frac{1}{2}$ , then show that  $3\cos \theta - 4 \cos^3 \theta = 0$ .

Solution:

$$\sin \theta = \frac{1}{2}, \sin \theta = \sin 30^\circ \Rightarrow \theta = 30^\circ$$

$$\text{L.H.S} = 3 \cos \theta - 4 \cos^3 \theta = 3 \cos 30^\circ - 4 \cos^3(30^\circ)$$

$$= 3 \frac{\sqrt{3}}{2} - 4 \left(\frac{\sqrt{3}}{2}\right)^3$$

$$= 3 \frac{\sqrt{3}}{2} - 4 \left(\frac{3\sqrt{3}}{8}\right) = 3 \frac{\sqrt{3}}{2} - 3 \frac{\sqrt{3}}{2} = 0 = \text{RHS}$$

10. If  $\tan \theta = \frac{a}{b}$ , prove that  $\frac{a \sin \theta - b \cos \theta}{a \sin \theta + b \cos \theta} = \frac{a^2 - b^2}{a^2 + b^2}$

Solution:

$$\begin{aligned} \text{LHS} &= \frac{a \sin \theta - b \cos \theta}{a \sin \theta + b \cos \theta} \\ &= \frac{\frac{a \sin \theta}{\cos \theta} - \frac{b \cos \theta}{\cos \theta}}{\frac{a \sin \theta}{\cos \theta} + \frac{b \cos \theta}{\cos \theta}} = \frac{a \tan \theta - b}{a \tan \theta + b} \end{aligned}$$

.....[Dividing numerator and denominator by  $\cos \theta$ ]

$$= \frac{a \left(\frac{a}{b}\right) - b}{a \left(\frac{a}{b}\right) + b} = \frac{\frac{a^2 - b^2}{b}}{\frac{a^2 + b^2}{b}} = \frac{a^2 - b^2}{a^2 + b^2} = \text{RHS}$$

### LONG ANSWER TYPE QUESTIONS (5 MARKS QUESTIONS)

1. Prove that:  $\frac{(\tan \theta + \sec \theta - 1)}{(\tan \theta - \sec \theta + 1)} = \frac{1 + \sin \theta}{\cos \theta}$

Solution :

$$\begin{aligned} \text{LHS} &= \frac{\tan \theta + \sec \theta - 1}{(\tan \theta - \sec \theta + 1)} = \frac{\tan \theta + \sec \theta - (\sec^2 \theta - \tan^2 \theta)}{(\tan \theta - \sec \theta + 1)} \\ &= \frac{\tan \theta + \sec \theta - [(\sec \theta + \tan \theta)(\sec \theta - \tan \theta)]}{(\tan \theta - \sec \theta + 1)} = \frac{(\tan \theta + \sec \theta)[1 - (\sec \theta - \tan \theta)]}{(\tan \theta - \sec \theta + 1)} \\ &= \frac{(\tan \theta + \sec \theta)(1 - \sec \theta + \tan \theta)}{(\tan \theta - \sec \theta + 1)} = \tan \theta + \sec \theta = \frac{\sin \theta}{\cos \theta} + \frac{1}{\cos \theta} = \frac{\sin \theta + 1}{\cos \theta} = \text{RHS} \end{aligned}$$

2. In an acute angled triangle ABC, if  $\sin (A + B - C) = \frac{1}{2}$  and  $\cos (B + C - A) = \frac{1}{\sqrt{2}}$ , find  $\angle A$ ,  $\angle B$  and  $\angle C$ .

Solution:  $\sin (A + B - C) = \frac{1}{2}$  ... ( $\because \sin 30^\circ = \frac{1}{2}$ )

$$A + B - C = 30^\circ \quad \dots \text{(i)}$$

$$A + B + C = 180^\circ \quad \dots \text{(ii)} \text{ (sum of all angles of a triangle = } 180^\circ \text{)}$$

$$\cos (B + C - A) = \frac{1}{\sqrt{2}} \quad \dots \text{(} \cos 45^\circ = \frac{1}{\sqrt{2}} \text{)}$$

$$B + C - A = 45^\circ \quad \dots \text{(iii)}$$

solving (i) and (ii),  $C = 75^\circ$

solving (iii) and (ii),  $A = 67.5^\circ$

Putting the values of A and C in (ii), we get

$$67.5^\circ + B + 75^\circ = 180^\circ$$

$$B = 180^\circ - 67.5^\circ - 75^\circ = 37.5^\circ$$

$\therefore \angle A = 67.5^\circ$ ,  $\angle B = 37.5^\circ$  and  $\angle C = 75^\circ$

3. If  $\tan (A + B) = \sqrt{3}$  and  $\tan (A - B) = \frac{1}{\sqrt{3}}$  where  $0 < A + B < 90^\circ$ ,  $A > B$ , find A and B.

Also calculate:  $\tan A \cdot \sin (A + B) + \cos A \cdot \tan (A - B)$ .

Solution: If  $\tan (A + B) = \sqrt{3}$  and  $\tan (A - B) = \frac{1}{\sqrt{3}}$

$$\tan(A + B) = \tan 60^\circ, \tan(A - B) = \tan 30^\circ$$

$$\therefore A + B = 60 \quad \dots \text{(i)}, \quad A - B = 30^\circ \quad \dots \text{(ii)}$$

Solving (i) and (ii),  $A = 45^\circ$ ,  $B = 15^\circ$

$$\therefore \tan A \cdot \sin(A + B) + \cos A \cdot \tan(A - B)$$

$$= \tan 45^\circ \cdot \sin(45^\circ + 15^\circ) + \cos 45^\circ \cdot \tan(45^\circ - 15^\circ)$$

$$= \tan 45^\circ \cdot \sin 60^\circ + \cos 45^\circ \cdot \tan 30^\circ = 1 \times \frac{\sqrt{3}}{2} + \frac{1}{\sqrt{2}} \times \frac{1}{\sqrt{3}} = \frac{\sqrt{3}}{2} + \frac{1 \times \sqrt{6}}{\sqrt{6} \times \sqrt{6}} = \frac{\sqrt{3}}{2} + \frac{\sqrt{6}}{6} = \frac{3\sqrt{3}}{6} + \frac{\sqrt{6}}{6} = \frac{3\sqrt{3} + \sqrt{6}}{6}$$

4. Find the value of  $\cos 60^\circ$  geometrically. Hence find  $\operatorname{cosec} 60^\circ$ .

Solution: Let  $\triangle ABC$  be an equilateral triangle.

Let each side of triangle be  $2a$ .

Since each angle in an equilateral  $\triangle$  is  $60^\circ$

$$\therefore \angle A = \angle B = \angle C = 60^\circ$$

Draw  $AD \perp BC$

In  $\triangle ADB$  and  $\triangle ADC$ ,

$$AB = AC \dots [\text{Each} = 2a]$$

$$AD = AD \dots [\text{Common}]$$

$$\angle 1 = \angle 2 \dots [\text{Each } 90^\circ]$$

$\therefore \triangle ADB \cong \triangle ADC \dots [\text{RHS congruency rule}]$

$$BD = DC = \frac{2a}{2} = a$$

$$\text{In rt. } \triangle ADB, \cos 60^\circ = \frac{BD}{AB} = \frac{a}{2a} = \frac{1}{2}$$

$$\therefore \operatorname{cosec} 60^\circ = \frac{1}{\sin 60^\circ} = \frac{1}{\sqrt{1 - \cos^2 60^\circ}} = \frac{1}{\sqrt{1 - \frac{1}{4}}} = \frac{1}{\sqrt{\frac{4-1}{4}}} = \frac{2}{\sqrt{3}} \times \frac{\sqrt{3}}{\sqrt{3}} = \frac{2\sqrt{3}}{3}$$

5. If  $a \cos \theta - b \sin \theta = c$ , prove that  $(a \sin \theta + b \cos \theta) = \sqrt{a^2 + b^2 - c^2}$

Solution: Given,  $a \cos \theta - b \sin \theta = c \dots (i)$

$$\text{Now, } a^2 + b^2 - c^2 = a^2 + b^2 - (a \cos \theta - b \sin \theta)^2$$

$$= a^2 + b^2 - (a^2 \cos^2 \theta + b^2 \sin^2 \theta - 2ab \cos \theta \sin \theta)$$

$$= a^2 + b^2 - [a^2(1 - \sin^2 \theta) + b^2(1 - \cos^2 \theta) - 2ab \cos \theta \sin \theta]$$

$$= a^2 + b^2 - (a^2 - a^2 \sin^2 \theta + b^2 - b^2 \cos^2 \theta - 2ab \cos \theta \sin \theta)$$

$$= a^2 + b^2 - a^2 + a^2 \sin^2 \theta - b^2 + b^2 \cos^2 \theta + 2ab \cos \theta \sin \theta$$

$$= a^2 \sin^2 \theta + b^2 \cos^2 \theta + 2ab \cos \theta \sin \theta$$

$$a^2 + b^2 - c^2 = (a \sin \theta + b \cos \theta)^2$$

$$\sqrt{a^2 + b^2 - c^2} = a \sin \theta + b \cos \theta, \text{ Hence proved}$$

### CASE BASED STUDY QUESTIONS ( 4 MARKS QUESTIONS)

- Soorya and her father go to meet her friend Avni for a party. When they reached to Avni's place, Soorya saw the roof of the house, which is triangular in shape. If she imagined the dimensions of the roof as given in the figure, then answer the following questions.

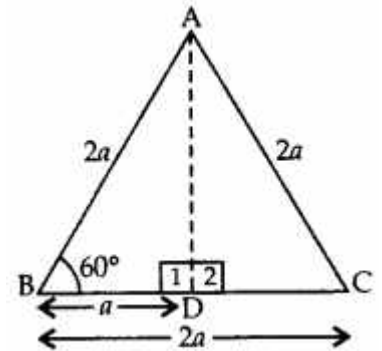
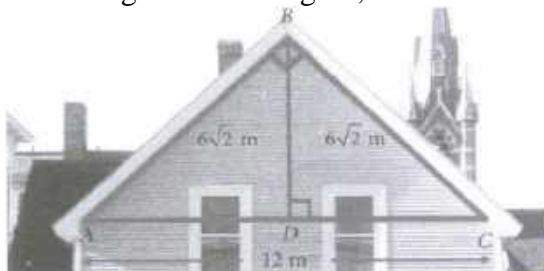

(i) If D is the midpoint of AC, then find the value of BD

Ans: 6m

(ii) Find the measure of  $\angle A$ .

Ans: 45

(iii) Find the value of  $\sin A + \cos C$ .

Ans:  $\sqrt{2}$

(OR)

Find the value of  $\tan^2 C + \tan^2 A$ .

Ans :2

2. Three friends – Anshu, Vijay, and Vishal are playing hide and seek in a park. Anshu and Vijay hide in the shrubs and Vishal have to find both of them. If the positions of the three friends are at A, B and C respectively as shown in the figure, and form a right-angled triangle such that  $AB = 9$  m,  $BC = 3\sqrt{3}$  m, and  $\angle B = 90^\circ$ , then answer the following questions.

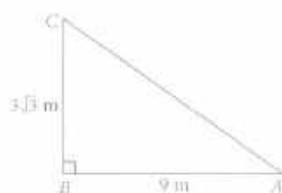

(i) Find the measure of  $\angle A$

Ans: 30

(ii) Find the measure of  $\angle C$

Ans : 60

(iii) Find the length of AC

Ans :  $6\sqrt{3}$  m

(OR)

Find the value of  $\sin A$  and  $\cos C$ . Check whether they are equal.

Ans: Yes

3. In structural design, a structure is composed of triangles that are interconnecting. A truss a series of triangle in same plane end is one of the major types of engineering structures and is especially used in the design of bridges and buildings. Trusses are designed to support loads, such as the weight of people. A truss is exclusively made of long, straight members connected by joints at the end of each member. This is a single repeating triangle in a truss system. Based on the above information, solve the following

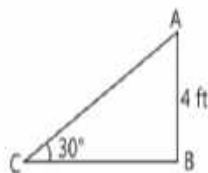

(i) In the above triangle, what is the length of AC?

Ans:  $AC = 8$  ft

(ii) In the above triangle, what is the length of BC?

Ans:  $BC = 4\sqrt{3}$  ft

(iii) If  $\sin A = \sin C$ , what will be the length of BC?

Ans: BC = 4ft

(OR)

If the length of AB doubles, what will be the length of AC?

Ans: AC = 16 ft

**HOTS (HIGH ORDER THINKING SKILLS)**

1. If  $\sqrt{3}\cot^2\theta - 4\cot\theta + \sqrt{3} = 0$ , then find the value of  $\cot^2\theta + \tan^2\theta$ .

Solution:  $\sqrt{3}\cot^2\theta - 4\cot\theta + \sqrt{3} = 0$

$$\sqrt{3}\cot^2\theta + \sqrt{3} = 0 + 4\cot\theta$$

$$\sqrt{3}(\cot^2\theta + 1) = 4\cot\theta$$

$$\frac{\cot^2\theta + 1}{\cot\theta} = \frac{4}{\sqrt{3}}$$

$$\frac{\cot^2\theta}{\cot\theta} + \frac{1}{\cot\theta} = \frac{4}{\sqrt{3}}$$

$$\cot\theta + \tan\theta = \frac{4}{\sqrt{3}}$$

$$\text{squaring both sides, } \cot^2\theta + \tan^2\theta + 2\cot\theta \cdot \tan\theta = \frac{16}{3}$$

$$\cot^2\theta + \tan^2\theta + 2 = \frac{16}{3} \quad \dots[\cot\theta \cdot \tan\theta = 1]$$

$$\cot^2\theta + \tan^2\theta = \frac{16}{3} - 2 = \frac{16-6}{3} = \frac{10}{3}$$

2. If  $\sec\theta - \tan\theta = x$ , show that  $\sec\theta + \tan\theta = \frac{1}{x}$  and hence find the values of  $\cos\theta$  and  $\sin\theta$ .

Solution  $\sec\theta - \tan\theta = x \quad \dots(i)$

$$\sec\theta + \tan\theta = \frac{1}{x} \quad \dots(ii)$$

$$\text{solving (i) and (ii) } 2\sec\theta = x + \frac{1}{x}$$

$$\sec\theta = \frac{1}{2}\left(x + \frac{1}{x}\right)$$

$$\frac{1}{\cos\theta} = \frac{1}{2} \frac{(x^2+1)}{x}$$

$$\frac{1}{\cos\theta} = \frac{(x^2+1)}{2x}$$

$$\text{Taking reciprocal, } \cos\theta = \frac{2x}{(x^2+1)}$$

$$\text{Squaring both sides } \cos^2\theta = \frac{4x^2}{(x^2+1)^2}$$

$$\text{Now } \sin^2\theta = 1 - \cos^2\theta$$

$$\sin^2\theta = 1 - \frac{4x^2}{(x^2+1)^2}$$

$$\sin^2\theta = \frac{(x^2+1)^2 - 4x^2}{(x^2+1)^2}$$

$$\sin^2\theta = \frac{x^4 + 2x^2 + 1 - 4x^2}{(x^2+1)^2}$$

$$\sin^2\theta = \frac{x^4 - 2x^2 + 1}{(x^2+1)^2}$$

$$\sin^2\theta = \frac{(x^2-1)^2}{(x^2+1)^2} \quad \because (x^2-1)^2 = x^4 - 2x^2 + 1$$

$$\therefore \sin\theta = \frac{x^2-1}{x^2+1}$$

3. If  $\tan\theta + \sin\theta = p$ ;  $\tan\theta - \sin\theta = q$ ; prove that  $p^2 - q^2 = 4\sqrt{pq}$

Solution:

$$\begin{aligned} \text{LHS} &= p^2 - q^2 \\ &= (\tan \theta + \sin \theta)^2 - (\tan \theta - \sin \theta)^2 \\ &= (\tan^2 \theta + \sin^2 \theta + 2 \tan \theta \sin \theta) - (\tan^2 \theta + \sin^2 \theta - 2 \tan \theta \sin \theta) \\ &= 2 \tan \theta \sin \theta + 2 \tan \theta \sin \theta = 4 \tan \theta \sin \theta \end{aligned}$$

$$\begin{aligned} \text{RHS} &= 4\sqrt{pq} = 4\sqrt{(\tan \theta + \sin \theta)(\tan \theta - \sin \theta)} \\ &= 4\sqrt{\tan^2 \theta - \sin^2 \theta} = 4\sqrt{\tan^2 \theta - \sin^2 \theta} = 4\sqrt{\frac{\sin^2 \theta}{\cos^2 \theta} - \sin^2 \theta} = 4\sqrt{\sin^2 \theta \left(\frac{1}{\cos^2 \theta} - 1\right)} \\ &= 4\sqrt{\sin^2 \theta \left(\frac{1 - \cos^2 \theta}{\cos^2 \theta}\right)} = 4\sqrt{\sin^2 \theta \left(\frac{\sin^2 \theta}{\cos^2 \theta}\right)} = 4\sqrt{\tan^2 \theta \sin^2 \theta} = 4 \tan \theta \cdot \sin \theta = \text{L.H.S} \end{aligned}$$

4. If  $\sin \theta + \cos \theta = m$  and  $\sec \theta + \text{cosec } \theta = n$ , then prove that  $n(m^2 - 1) = 2m$ .

$$\begin{aligned} \text{Solution: } m^2 - 1 &= (\sin \theta + \cos \theta)^2 - 1 \\ &= \sin^2 \theta + \cos^2 \theta + 2 \sin \theta \cos \theta - 1 \\ &= 1 + 2 \sin \theta \cos \theta - 1 \\ &= 2 \sin \theta \cos \theta \dots [\sin^2 \theta + \cos^2 \theta = 1] \end{aligned}$$

$$\begin{aligned} \text{L.H.S.} &= n(m^2 - 1) \\ &= (\sec \theta + \text{cosec } \theta) \times 2 \sin \theta \cos \theta \\ &= \left(\frac{1}{\cos \theta} + \frac{1}{\sin \theta}\right) \times 2 \sin \theta \cos \theta \\ &= \left(\frac{\sin \theta + \cos \theta}{\sin \theta \cos \theta}\right) \times 2 \sin \theta \cos \theta \\ &= 2(\sin \theta + \cos \theta) = 2m = \text{R.H.S} \end{aligned}$$

5. Find the value of:

$$\frac{\sin \theta}{\sec \theta + \tan \theta - 1} + \frac{\cos \theta}{\text{cosec } \theta + \cot \theta - 1}$$

Solution:

$$\begin{aligned} \frac{\sin \theta}{\sec \theta + \tan \theta - 1} + \frac{\cos \theta}{\text{cosec } \theta + \cot \theta - 1} &= \frac{\sin \theta}{\frac{1}{\cos \theta} + \frac{\sin \theta}{\cos \theta} - 1} + \frac{\cos \theta}{\frac{1}{\sin \theta} + \frac{\cos \theta}{\sin \theta} - 1} \\ &= \frac{\sin \theta}{\frac{1 + \sin \theta - \cos \theta}{\cos \theta}} + \frac{\cos \theta}{\frac{1 + \cos \theta - \sin \theta}{\sin \theta}} = \frac{\sin \theta \cos \theta}{1 + \sin \theta - \cos \theta} + \frac{\cos \theta \sin \theta}{1 + \cos \theta - \sin \theta} \\ &= \sin \theta \cos \theta \left( \frac{1}{1 + \sin \theta - \cos \theta} + \frac{1}{1 + \cos \theta - \sin \theta} \right) \\ &= \sin \theta \cos \theta \left( \frac{1 + \cos \theta - \sin \theta + 1 + \sin \theta - \cos \theta}{(1 + \sin \theta - \cos \theta)(1 + \cos \theta - \sin \theta)} \right) \\ &= \sin \theta \cos \theta \left( \frac{2}{(1 + \sin \theta - \cos \theta)(1 + \cos \theta - \sin \theta)} \right) \\ &= \sin \theta \cos \theta \left( \frac{2}{(1 + \sin \theta - \cos \theta)[1 - (\sin \theta - \cos \theta)]} \right) \\ &= \sin \theta \cos \theta \left( \frac{2}{1^2 - (\sin \theta - \cos \theta)^2} \right) \\ &= \sin \theta \cos \theta \left( \frac{2}{1 - (\sin^2 \theta + \cos^2 \theta - 2 \sin \theta \cos \theta)} \right) \\ &= \sin \theta \cos \theta \left( \frac{2}{1 - (1 - 2 \sin \theta \cos \theta)} \right) \\ &= \sin \theta \cos \theta \left( \frac{2}{1 - 1 + 2 \sin \theta \cos \theta} \right) \\ &= \sin \theta \cos \theta \left( \frac{2}{2 \sin \theta \cos \theta} \right) = 1 \end{aligned}$$

**CHAPTER 9**  
**APPLICATIONS OF TRIGONOMETRY**  
**MIND MAP**

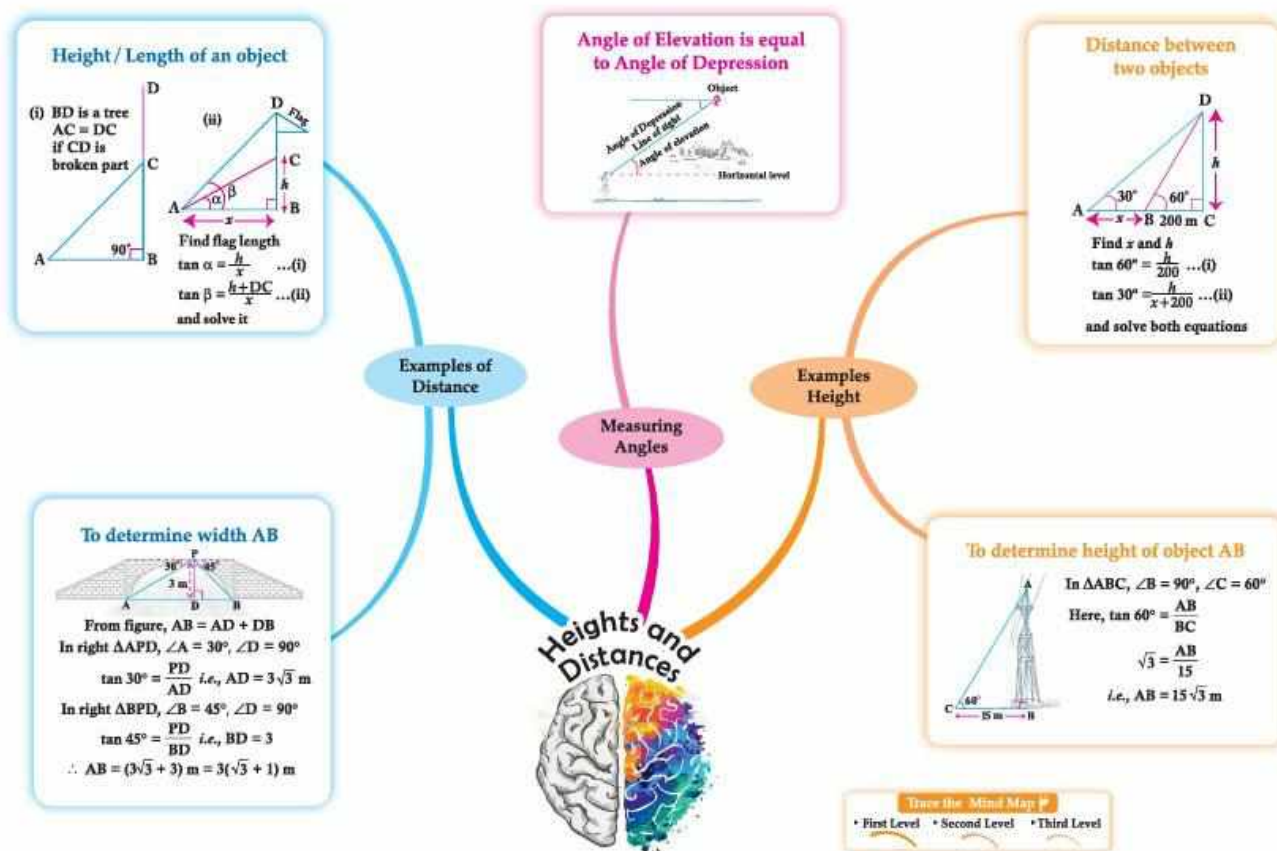

**GIST OF THE CHAPTER**

1. Line of sight
2. Angle of elevation
3. Angle of depression

**DEFINITION**

1. The line of sight is the line drawn from the eye of an observer to the point in the object viewed by the observer.
2. The angle of elevation of an object viewed, is the angle formed by the line of sight with the horizontal when it is above the horizontal level, i.e., the case when we raise our head to look at the object.
3. The angle of depression of an object viewed, is the angle formed by the line of sight with the horizontal when it is below the horizontal level, i.e., the case when we lower our head to look at the object.

**MULTIPLE CHOICE QUESTIONS(1 MARK QUESTIONS)**

1. If the length of the shadow of a tree decreases then the angle of elevation :  
 (a) Increases                      (b) Decreases                      (c) Remains the same                      (d) None of the above  
 Ans (a) Increases
2. The angle of elevation of the top of a building from a point on the ground, which is 30 m away from the foot of the building, is  $30^\circ$ . The height of the building is:  
 (a) 10 m                      (b)  $30/\sqrt{3}$  m                      (c)  $\sqrt{3}/10$  m                      (d) 30 m  
 Ans : (b)  $30/\sqrt{3}$  m

3.If the height of the building and distance from the building foot to a point is increased by 20%, then the angle of elevation on the top of the building:

- (a) Increases (b) Decreases (c) Do not change (d) None of the above

Ans : (c) Do not change

4.If a tower 6m high casts a shadow of  $2\sqrt{3}$  m long on the ground, then the sun's elevation is:

- (a)  $60^\circ$  (b)  $45^\circ$  (c)  $30^\circ$  (d)  $90^\circ$

Ans: (a)  $60^\circ$

5. The angle of elevation of the top of a building 30 m high from the foot of another building in the same plane is  $60^\circ$ , and also the angle of elevation of the top of the second tower from the foot of the first tower is  $30^\circ$ , then the distance between the two buildings is:

- (a)  $10\sqrt{3}$  m (b)  $15\sqrt{3}$  m (c)  $12\sqrt{3}$  m (d) 36 m

Ansr: (a)  $10\sqrt{3}$  m

6.The angle formed by the line of sight with the horizontal when the point is below the horizontal level is called:

- (a) Angle of elevation (b) Angle of depression  
(c) No such angle is formed (d) None of the above

Ans : (b) Angle of depression

7.From a point on the ground, which is 15 m away from the foot of the tower, the angle of elevation of the top of the tower is found to be  $60^\circ$ . The height of the tower (in m) standing straight is:

- (a)  $15\sqrt{3}$  (b)  $10\sqrt{3}$  (c)  $12\sqrt{3}$  (d)  $20\sqrt{3}$

Ans: (a)  $15\sqrt{3}$

8.The angle formed by the line of sight with the horizontal when the point being viewed is above the horizontal level is called:

- (a) Angle of elevation (b) Angle of depression  
(c) No such angle is formed (d) None

Ans: (a) Angle of elevation

9. When the shadow of a pole h metres high is  $\sqrt{3}h$  metres long, the angle of elevation of the Sun is

- (a)  $30^\circ$  (b)  $60^\circ$  (c)  $45^\circ$  (d)  $15^\circ$

Ans: (a)  $30^\circ$

10.A ladder makes an angle of  $60^\circ$  with the ground, when placed along a wall. If the foot of ladder is 8 m away from the wall, the length of ladder is

- (a) 4 m (b) 8 m (c)  $8\sqrt{3}$  m (d) 16 m

Ans: (d) 16 m

### **ASSERTION AND REASONING QUESTIONS**

**DIRECTION:** In the following questions, a statement of **Assertion (A)** is followed by a statement of **Reason (R)**. Choose the correct option

- (a) Both assertion (A) and reason (R) are true and reason (R) is the correct explanation of assertion (A)  
(b) Both assertion (A) and reason (R) are true and reason (R) is not the correct explanation of assertion (A)  
(c) Assertion (A) is true but reason (R) is false.  
(d) Assertion (A) is false but reason (R) is true.

1.**Assertion (A):** The height of a tower can be found using the angle of elevation and the horizontal distance from the base.

**Reason (R) :** The relation  $\tan \theta = \frac{\text{Height}}{\text{Base}}$  holds true in right-angled triangles.

Ans:(b)

2.**Assertion (A):** The angle of elevation of the top of a building increases as the observer approaches the building.

**Reason (R):** A larger angle of elevation implies a taller object.

Ans:(c)

3. **Assertion (A):** When the sun is lower in the sky (early morning or evening), the shadow of a vertical object is larger.

**Reason (R):** The angle of elevation of the sun is small during early morning or evening.

Ans: (a)

4. **Assertion (A):** The angle of depression from a lighthouse to a boat is equal to the angle of elevation from the boat to the lighthouse.

**Reason (R):** These angles are alternate interior angles formed by a transversal intersecting two parallel lines.

Ans: (a)

5. **Assertion (A):** The height of a tower can be calculated by observing the angle of elevation from two different points on a straight line and knowing the distance between them.

**Reason (R):** The angle of elevation of the top of a tower increases as the observer approaches the tower.

Ans: (b)

6. **Assertion (A):** If the length of the shadow of a vertical pole is equal to its height, then the angle of elevation of the sun is  $45^\circ$ .

**Reason (R):** According to Pythagoras theorem,  $(\text{hypotenuse})^2 = (\text{altitude})^2 + (\text{base})^2$ ,

Ans: (b)

7. **Assertion (A):** In the figure, if  $BC = 20$  m, then height  $AB$  is 11.56 m.

**Reason (R):**  $\tan \theta = \frac{AB}{BC} = \frac{\text{perpendicular}}{\text{base}}$ , where  $\theta$  is the angle  $\angle ACB$

Ans: (a)

8. **Assertion (A):** The value of  $\sin 90^\circ = 0$ .

**Reason (R):** The value of  $\cos 90^\circ = 0$

Ans: (d)

9. **Assertion (A):** If the shadow of a vertical pole is  $\frac{1}{\sqrt{3}}$  times its height, then the angle of elevation of the tower is  $60^\circ$

**Reason (R):** If the angle of elevation of a vertical pole is  $45^\circ$ , then the shadow of the vertical pole is same as its height.

Ans: (b)

10. **Assertion (A):**  $\sin \theta = \frac{\text{opposite side}}{\text{hypotenuse}}$

**Reason (R):**  $\tan 90^\circ = 0$

Ans: (c)

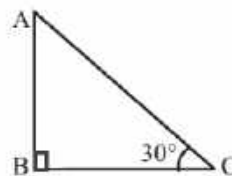

### VERY SHORT ANSWER TYPE QUESTIONS (2 MARK QUESTIONS)

1. If the height and length of a shadow of a tower are the same, then find the angle of elevation of Sun

Solution : Let  $AB$  be the tower and  $BC$  be its shadow.

$AB = BC$

In right triangle  $ABC$ ,  $\tan \theta = \frac{AB}{BC}$

$\tan \theta = \frac{AB}{AB}$  (since  $AB = BC$ )

$\tan \theta = 1 \Rightarrow \tan \theta = \tan 45^\circ \therefore \theta = 45^\circ$

2. The angle of depression of an object on the ground, from the top of a 25 m high tower is  $30^\circ$ . find the distance of the object from the base of tower  
Solution: Let  $AB$  be the tower and  $BC$  be the distance of the object (at  $C$ ) from the base of the tower.

In right triangle  $ABC$ ,

$\tan 30^\circ = \frac{AB}{BC}$

$\frac{1}{\sqrt{3}} = \frac{25}{BC} \Rightarrow BC = 25\sqrt{3}$  m

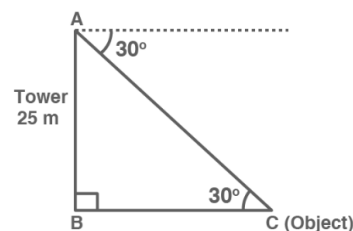
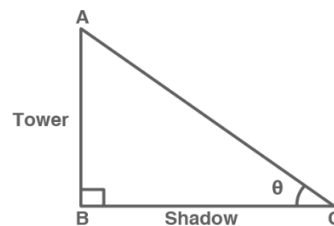

3. The shadow of a tower standing on level ground is found to be 40 m longer when the Sun's altitude is  $30^\circ$  than when it was  $60^\circ$ . Find the height of the tower.

Solution: Let AB be h m and BC be x m. From the question, DC is 40 m longer than BC.  $BD = (40 + x)$  m

$$\text{In } \triangle ABC, \tan 60^\circ = \frac{AB}{BC} \Rightarrow \sqrt{3} = \frac{h}{x} \Rightarrow x = \frac{h}{\sqrt{3}} \dots (i)$$

In  $\triangle ABD$ ,

$$\tan 30^\circ = \frac{AB}{BD} = \frac{1}{\sqrt{3}}$$

$$\frac{h}{x+40} = \frac{1}{\sqrt{3}} \Rightarrow x + 40 = \sqrt{3}h$$

$$\frac{h}{\sqrt{3}} + 40 = \sqrt{3}h \quad [\text{using (i)}]$$

$$h + 40\sqrt{3} = 3h \Rightarrow h = 20\sqrt{3}\text{m}$$

4. The ratio of the height of a tower and the length of its shadow on the ground is  $\sqrt{3} : 1$ . Find the angle of elevation of the Sun

Solution: Given,  $AB : BC = \sqrt{3} : 1$

So,  $AB = \sqrt{3}x$  and  $BC = x$

In right triangle ABC,

$$\tan \theta = \frac{AB}{BC}$$

$$\tan \theta = \frac{\sqrt{3}x}{x} \Rightarrow \tan \theta = \sqrt{3} \Rightarrow \tan \theta = \tan 60^\circ \Rightarrow \theta = 60^\circ$$

5. A tree breaks due to a storm and the broken part bends so that the top of the tree touches the ground making an angle of  $30^\circ$  with the ground. The distance between the foot of the tree to the point where the top touches the ground is 8 m. Find the height of the tree.

Solution: Let AC be the initial height of the tree. Let the bent portion of the tree be  $AB = x$  m and the remaining portion  $BC = h$  m.

So, the height of the tree  $AC = (x + h)$  m

In right  $\triangle BCD$ ,

$$\tan 30^\circ = \frac{BC}{DC} = \frac{h}{8} \Rightarrow \frac{h}{8} = \frac{1}{\sqrt{3}} \Rightarrow h = \frac{8}{\sqrt{3}}\text{m}$$

$$\text{In right } \triangle ABC, \cos 30^\circ = \frac{DC}{BD}$$

$$\frac{\sqrt{3}}{2} = \frac{8}{x} \Rightarrow x = \frac{16}{\sqrt{3}}\text{m}$$

$$\text{So, } x + h = \frac{16}{\sqrt{3}} + \frac{8}{\sqrt{3}} = 8\sqrt{3}\text{m}$$

6. The tops of two poles of height 16 m and 12 m are connected by a wire, the wire makes angle of  $30^\circ$  with the horizontal, find length of wire.

Solution: In right  $\triangle EDC$ ,  $\sin \theta = \frac{ED}{EC}$

$$\sin 30^\circ = \frac{4}{l} \Rightarrow \frac{1}{2} = \frac{4}{l} \Rightarrow l = 8\text{ m}$$

7. An observer 1.5 m tall is 28.5 m away from a tower of height 30 m. Find the angle of elevation of the top of tower from his eye.

Solution:

$$\text{In right } \triangle ABC, \tan \theta = \frac{BC}{AB}$$

$$\tan \theta = \frac{28.5}{28.5} = 1 = \tan 45^\circ \therefore \theta = 45^\circ$$

8. A ladder, leaning against a wall, makes an angle of  $60^\circ$  with the horizontal. If the foot of the ladder is 2.5 m away from the wall, find the length of the ladder.

Solution:

Let AC be the ladder and the foot C is 2.5 m away from the wall AB.

$$\cos 60^\circ = \frac{BC}{AC} = \frac{2.5}{h}$$

$$\frac{1}{2} = \frac{2.5}{h} \therefore h = 5\text{ m.}$$

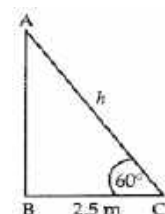
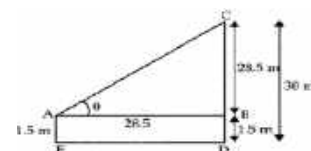
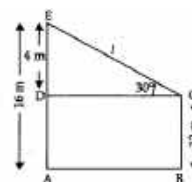
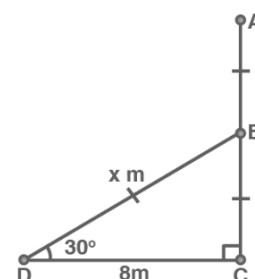
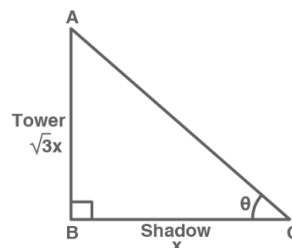
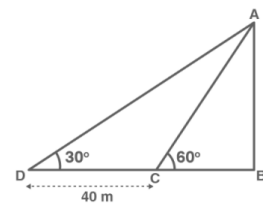

9. AB is a 6 m high pole and CD is a ladder inclined at an angle of  $60^\circ$  to the horizontal and reaches up to a point D of pole. If  $AD = 2.54$  m, find the length of the ladder. (use  $\sqrt{3} = 1.73$ )

Solution:

$$AB = AD + DB = 6 \text{ m (given)}$$

$$\Rightarrow 2.54 \text{ m} + DB = 6 \text{ m}$$

$$\Rightarrow DB = 3.46 \text{ m}$$

Now, in the right  $\Delta BCD$ .

$$\frac{BD}{CD} = \sin 60$$

$$\frac{3.46}{CD} = \frac{\sqrt{3}}{2} \quad \therefore CD = 4 \text{ m}$$

10. A moving boat is observed from the top of a 150 m high cliff moving away from the cliff. The angle of depression of the boat changes from  $60^\circ$  to  $45^\circ$  in 2 minutes. Find the speed of the boat in m/h.

Solution: Let C & D be two positions of the boat & AB be the cliff & let speed of boat be x m/min.

Let  $BC = y$

$$\therefore CD = 2x \quad (\because \text{Distance} = \text{speed} \times \text{time})$$

$$\text{In } \Delta ABC, \frac{150}{y} = \tan 60^\circ$$

$$\Rightarrow y = \frac{150}{\sqrt{3}} = 50\sqrt{3} \text{ m}$$

$$\text{In } \Delta ABD, \frac{150}{y+2x} = \tan 45^\circ \Rightarrow \frac{150}{50\sqrt{3}+2x} = 1$$

$$50\sqrt{3} + 2x = 150$$

$$\therefore x = \frac{150 - 50\sqrt{3}}{2} = 75 - 25\sqrt{3}$$

$$\Rightarrow x = 25(3 - \sqrt{3})$$

$$\therefore \text{Speed} = 25(3 - \sqrt{3}) \text{ m/min}$$

$$= 1500(3 - \sqrt{3}) \text{ m/hr.}$$

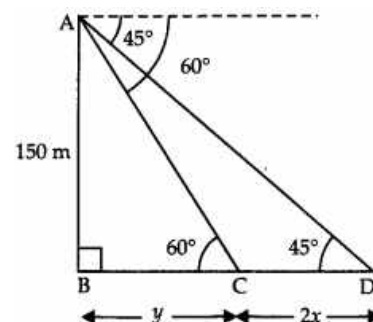
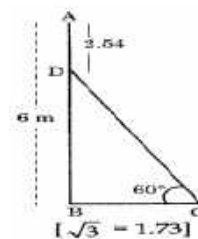

### SHORT ANSWER TYPE QUESTIONS (3 MARK QUESTIONS)

1. From a point on a bridge across a river the angle of depression of the banks on opposite sides of the river are  $30^\circ$  and  $45^\circ$  respectively. If the bridge is at the height of 30 m from the banks, find the width of the river.

Solution: Let, A and B represent the points on the bank on opposite sides of the river. And, AB is the width of the river.

$$AB = AD + DB$$

In right  $\Delta APD$

$$\text{So, } \tan 30^\circ = \frac{PD}{AD}$$

$$\frac{1}{\sqrt{3}} = \frac{PD}{AD}$$

$$AD = 30\sqrt{3} \text{ m}$$

$$\text{In right } \Delta PBD, \tan 45^\circ = \frac{PD}{BD} \Rightarrow BD = 30 \text{ m}$$

$$\text{Since } AB = AD + DB = 30\sqrt{3} + 30 = 30(\sqrt{3} + 1) \text{ m}$$

2. From the top of a 7 m high building, the angle of elevation of the top of a tower is  $60^\circ$  and the angle of depression of its foot is  $45^\circ$ . Find the height of the tower.

Solution: Let BG be building

TW be Tower, then:  $BM = x$ ,  $\angle MBT = 60^\circ$   $\angle MBW = 45^\circ$

In rt.  $\Delta BMW$

$$\tan 45^\circ = \frac{WM}{BM} \Rightarrow 1 = \frac{7}{x} \Rightarrow x = 7 \text{ m}$$

In rt.  $\Delta TMB$

$$\tan 60^\circ = \frac{TM}{BM} \Rightarrow \sqrt{3} = \frac{h}{x}$$

$$\Rightarrow h = \sqrt{3}x = 7\sqrt{3}$$

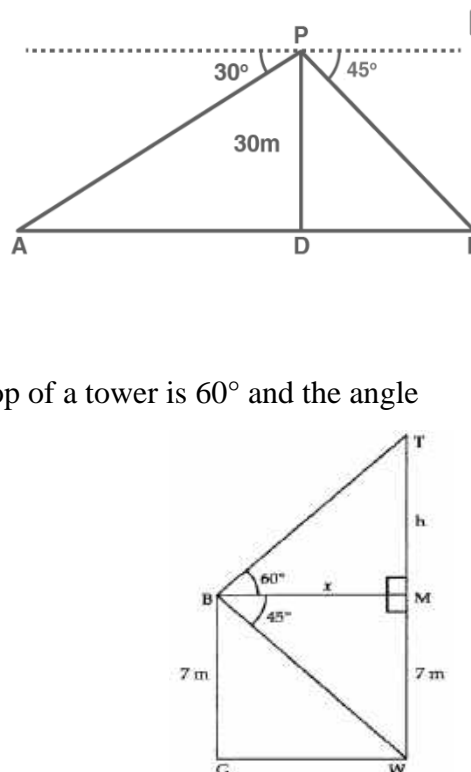

Height of Tower = TW = TM + MW

$$= (7\sqrt{3} + 7)m = 7(\sqrt{3} + 1)m$$

3. A contractor plans to install two slides for the children to play in a park. For the children below the age of 5 years, she prefers to have a slide whose top is at a height of 1.5 m, and is inclined at an angle of  $30^\circ$  to the ground, whereas for elder children, she wants to have a steep slide at a height of 3 m, and inclined at an angle of  $60^\circ$  to the ground. What should be the length of the slide in each case?

Solution: (i) In  $\triangle ABC$ ,  $\sin 30^\circ = AC / BC$

$$\frac{1}{2} = \frac{1.5}{BC}, \quad BC = 1.5 \times 2 \quad \therefore BC = 3$$

(ii) In  $\triangle PRQ$ ,  $\sin Q = \frac{PR}{QR} \Rightarrow \sin 60^\circ = \frac{3}{QR} = \frac{\sqrt{3}}{2} = \frac{3}{QR}$

$$\Rightarrow QR = \frac{6}{\sqrt{3}} = 2\sqrt{3} \text{ m}$$

Length of the slide for children below 5 years = 3 m

Length of the slide for elder children =  $2\sqrt{3}$  m

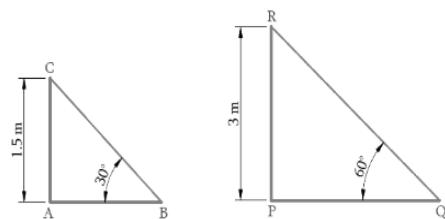

4. From the top of a 25 m high cliff, the angle of elevation of a tower is found to be equal to the angle of depression of the foot of the tower. Find height of the tower.

Solution: In right  $\triangle ABC$ ,

$$\tan \theta = \frac{BC}{AB} \Rightarrow \tan \theta = \frac{25}{x}$$

In  $\triangle CDE$ ,  $\tan \theta = \frac{DE}{CD}$

$$\Rightarrow \tan \theta = \frac{y}{x}$$

$$\frac{25}{x} = \frac{y}{x} \Rightarrow y = 25 \text{ m} \quad \therefore \text{Height of tower} = x + y = 25 + 25 = 50 \text{ m}$$

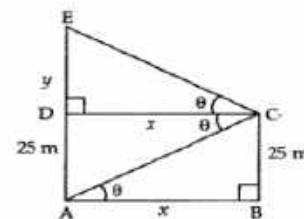

5. The tops of two poles of height 16 m and 12 m are connected by a wire, the wire makes angle of  $30^\circ$  with the horizontal, find length of wire.

Solution: In right  $\triangle EDC$ ,

$$\sin \theta = \frac{ED}{EC}$$

$$\sin 30^\circ = \frac{4}{l} \Rightarrow \frac{1}{2} = \frac{4}{l} \Rightarrow l = 8 \text{ m}$$

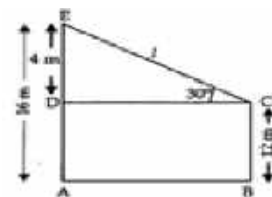

6. The angle of elevation of the top of a hill at the foot of a tower is  $60^\circ$  and the angle of elevation of the top of the tower from the foot of the hill is  $30^\circ$ . If height of the tower is 50 m, find the height of the hill.

Solution: Let HL be Hill and TW be Tower angle of elevations  $\angle WLT = 30^\circ$

$\angle LWH = 60^\circ$ , let  $WL = x$

In rt.  $\triangle LWT$

$$\Rightarrow \frac{50}{x} = \tan 30^\circ$$

$$\Rightarrow x = 50\sqrt{3} \dots\dots (i)$$

In rt.  $\triangle WLH$

$$\Rightarrow \frac{h}{x} = \tan 60^\circ \Rightarrow \frac{h}{50\sqrt{3}} = \sqrt{3} \Rightarrow h = 50\sqrt{3} \times \sqrt{3} = 150 \text{ [Using (i)]}$$

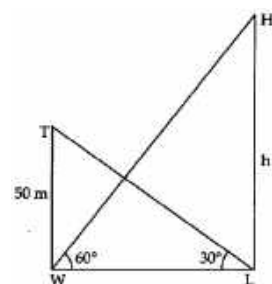

7. The angles of depression of the top and bottom of a 50 m high building from the top of a tower are  $45^\circ$  and  $60^\circ$  respectively. Find the height of the tower and the horizontal distance between the tower and the building, (use  $\sqrt{3} = 1.73$ ).

Solution: Let the height of the tower AB be h metres and the horizontal distance between the tower and the building BC be x metres.

So,  $AE = (h - 50)$  m

In  $\triangle AED$ ,  $\tan 45^\circ = \frac{AE}{ED}$

$$\Rightarrow 1 = \frac{h-50}{x}$$

$$\Rightarrow x = h - 50 \dots\dots\dots (i)$$

In  $\triangle ABC$ ,  $\tan 60^\circ = \frac{AB}{BC}$   
 $\Rightarrow \sqrt{3} = \frac{h}{x} \Rightarrow \sqrt{3}x = h \dots\dots (ii)$

Using (i) and (ii), we get

$\Rightarrow x = \sqrt{3}x - 50$   
 $\Rightarrow x(\sqrt{3} - 1) = 50$   
 $\Rightarrow x = \frac{50}{\sqrt{3} - 1}$   
 $\Rightarrow x = 68.25 \text{ m}$

Substituting the value of x in (i), we get

$68.25 = h - 50$   
 $\Rightarrow h = 68.25 + 50$   
 $\Rightarrow h = 118.25 \text{ m}$

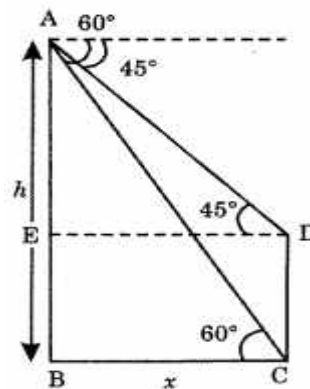

8. There are two poles, one each on either bank of a river, just opposite to each other. One pole is 60 m high. From the top of this pole, the angles of depression of the top and the foot of the other pole are  $30^\circ$  and  $60^\circ$  respectively. Find the width of the river and height of the other pole.

Solution: Let AB, CD be two poles separated by river of width CA with AB = 60 m and let CD = h m

Draw  $DE \perp AB$

$BE = AB - EA = (60 - h) \text{ m}$

In right  $\triangle BAC$

$\tan 60 = \frac{BA}{CA}$   
 $\Rightarrow \sqrt{3} = \frac{60}{CA} \Rightarrow CA = \frac{60}{\sqrt{3}} \text{ m} = 20\sqrt{3} \text{ m}$

Thus, width of river =  $20\sqrt{3} \text{ m}$

In  $\triangle BED$

$\tan 30^\circ = \frac{BE}{DE}$   
 $\Rightarrow \frac{1}{\sqrt{3}} = \frac{60-h}{20\sqrt{3}} \Rightarrow 20 = 60 - h$   
 $\Rightarrow h = 60 - 20 = 40$

Height of the other pole = 40 m.

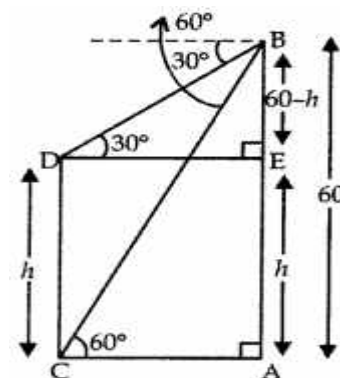

9. Two ships are there in the sea on either side of a lighthouse in such a way that the ships and the lighthouse are in the same straight line. The angles of depression of two ships as observed from the top of the lighthouse are  $60^\circ$  and  $45^\circ$ . If the height of the lighthouse is 200 m, find the distance between the two ships. [Use  $\sqrt{3} = 1.73$ ]

Solution:

In  $\triangle ABD$ ,

$\tan \theta = \frac{BD}{AB}$   
 $\tan 60 = \frac{200}{x} \Rightarrow x = \frac{200}{\sqrt{3}} = 115.4 \text{ m}$

In  $\triangle DBC$ ,

$\tan \theta = \frac{BD}{BC} \Rightarrow \tan 45 = \frac{200}{y}$   
 $\Rightarrow y = 200 \text{ m}$

Distance between two ships =  $x + y$   
 $= 115.4 + 200 = 315.4 \text{ m}$

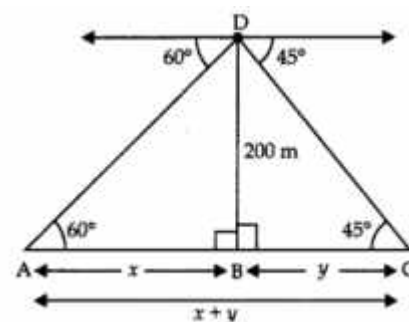

10. The angles of elevation and depression of the top and the bottom of a tower from the top of a building, 60 m high, are  $30^\circ$  and  $60^\circ$  respectively. Find the difference between the heights of the building and the tower and the distance between them.

Answer:

In  $\triangle ABE$ ,

$$\tan \theta = \frac{BE}{AB} \Rightarrow \tan 60^\circ = \frac{60}{x} \Rightarrow \sqrt{3} = \frac{60}{x}$$

$$x = \frac{60}{\sqrt{3}} = 20\sqrt{3} \text{ m}$$

In  $\triangle DCE$ ,

$$\tan \theta = \frac{EC}{CD}$$

$$\tan 30^\circ = \frac{y}{x} \Rightarrow \frac{1}{\sqrt{3}} = \frac{y}{20\sqrt{3}} \Rightarrow y = 20 \text{ m}$$

$\therefore$  Difference between heights of the building and tower =  $y = 20 \text{ m}$

Distance between tower and building =  $x = 20\sqrt{3} \text{ m}$

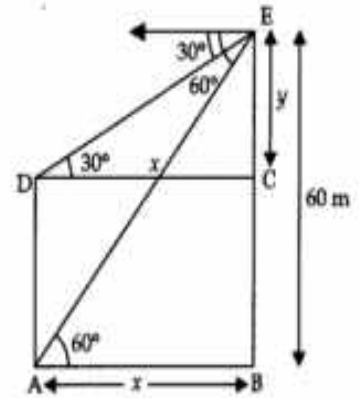

**LONG ANSWER TYPE QUESTIONS (5 MARK QUESTIONS)**

1. The angle of elevation of a cloud from a point 60 m above the surface of the water of a lake is  $30^\circ$  and the angle of depression of its shadow in water of lake is  $60^\circ$ . Find the height of the cloud from the surface of water.

Solution: Let C be cloud & B be point 60 m above the surface of water angle

of elevation of cloud =  $\angle MBC = 30^\circ$

Angle & Depression of clouds reflection

'R'  $\angle MBR = 60^\circ$

Let  $BM = x$ ,  $CM = h$ ,  $NR = 60 + h$ ,

$MR = 60 + 60 + h = 120 + h$

In rt.  $\triangle BMC$

$$\frac{h}{x} = \tan 30^\circ = \frac{1}{\sqrt{3}}$$

$$\Rightarrow x = h\sqrt{3} \dots (i)$$

In rt.  $\triangle BMR$

$$\frac{60+60+h}{x} = \tan 60^\circ$$

$$\Rightarrow \frac{120+h}{x} = \sqrt{3}$$

$$\Rightarrow 120 + h = h\sqrt{3} \times \sqrt{3} \text{ [using (i)]}$$

$$\Rightarrow h = 60$$

$\therefore$  height of cloud from surface of water =  $(60 + 60)\text{m} = 120 \text{ m}$ .

2. A man is standing on the deck of a ship, which is 8 m above water level. He observes the angle of elevation of the top of a hill as  $60^\circ$  and the angle of depression of the base of the hill as  $30^\circ$ . Calculate the distance of the hill from the ship and the height of the hill.

Solution: Let  $x \text{ m}$  be the distance between hill and man. The angles of elevation and depression are  $60^\circ$  and  $30^\circ$  respectively. Various arrangements are as shown in the figure.

In right  $\triangle DBA$ ,  $\frac{AB}{BD} = \tan 60^\circ$

$$\frac{h}{x} = \sqrt{3}$$

$$h = \sqrt{3}x \dots (i)$$

In right  $\triangle DBC$ ,  $\frac{BC}{BD} = \tan 30^\circ$

$$\frac{8}{x} = \frac{1}{\sqrt{3}}$$

$$x = 8\sqrt{3} \dots (ii)$$

From (i) and (ii), we get

$$h = \sqrt{3} \times 8\sqrt{3} = 8 \times 3 = 24 \text{ m}$$

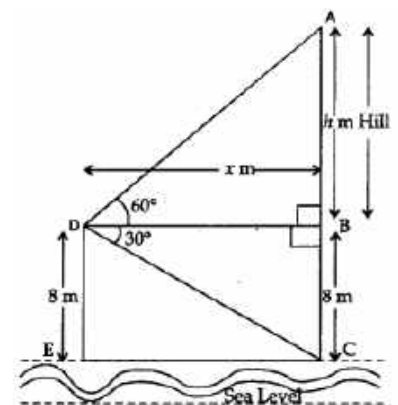

∴ Height of hill =  $(h + 8) \text{ m} = (24 + 8) \text{ m} = 32 \text{ m}$

Hence, height of hill and distance of man from hill are 32 m and  $8\sqrt{3}$  m respectively.

3. The angles of depression of the top and bottom of a building 50 metres high as observed from the top of a tower are  $30^\circ$  and  $60^\circ$ , respectively. Find the height of the tower and also the horizontal distance between the building and the tower.

Solution: In fig. Let BG be the building & TR be Tower

$\angle XTB = 30^\circ$ ,  $\angle XTG = 60^\circ$

$\angle TBP = \angle XTB = 30^\circ$  [alt. angles]

$\angle TGR = \angle XTG = 60^\circ$  [alt. angles]

In  $\Delta BTP \Rightarrow \tan 30^\circ = \frac{TP}{BP}$

$BP = TP\sqrt{3}$

In  $\Delta TGR \tan 60^\circ = \frac{TR}{GR} \Rightarrow \sqrt{3} = \frac{TR}{GR}$

Now,  $TP\sqrt{3} = \frac{TR}{\sqrt{3}}$  (as  $BP = GR$ )

$\Rightarrow 3TP = TR + PR$

$\Rightarrow 2TP = BG \Rightarrow TP = 25 \text{ m} = 25 \text{ m}$

Now,  $TR = TP + PR = (25 + 50) \text{ m}$ .

Height of tower =  $TR = 75 \text{ m}$ .

In  $\Delta TGR \tan 60^\circ = \frac{TR}{GR} \Rightarrow \sqrt{3} = \frac{TR}{GR}$

Distance between building and tower =  $GR$

$\Rightarrow GR = \frac{75}{\sqrt{3}} \text{ m} = 25\sqrt{3} \text{ m}$

4. A bird is sitting on the top of a 80 m high tree. From a point on the ground, the angle of elevation of the bird is  $45^\circ$ . The bird flies away horizontally in such a way that it remained at a constant height from the ground. After 2 seconds, the angle of elevation of the bird from the same point is  $30^\circ$ . Find the speed of flying of the bird. (Take  $\sqrt{3} = 1.732$ )

Solution: Let P and Q be the two positions of the bird, and let A be the point of observation. Let ABC be the horizontal line through A.

Given, The angles of elevations  $\angle PAB = 45^\circ$  and

$\angle QAB = 30^\circ$ , respectively.

∴  $\angle PAB = 45^\circ$  and  $\angle QAB = 30^\circ$

Also,  $PB = 80 \text{ m}$

In  $\Delta ABP$ , we have  $\tan 45^\circ = \frac{BP}{AB}$

$\Rightarrow 1 = \frac{80}{AB}$

$\Rightarrow AB = 80 \text{ m}$

In  $\Delta ACQ$ , we have  $\tan 30^\circ = \frac{CQ}{AC}$

$\Rightarrow \frac{1}{\sqrt{3}} = \frac{80}{AC}$

$\Rightarrow AC = 80\sqrt{3} \text{ m}$

∴  $PQ = BC = AC - AB$

$= 80\sqrt{3} - 80 = 80(\sqrt{3} - 1)$

So, the bird covers  $80(\sqrt{3} - 1) \text{ m}$  in 2 s.

Thus, speed of the bird

$= \frac{\text{Distance}}{\text{Time}} = \frac{80(\sqrt{3}-1)}{2} \text{ m/s}$

$= 40(\sqrt{3}-1) \times 60 \times 60 \text{ km/h}$

$= 144(1.732 - 1) \text{ km/h}$

$= 105.408 \text{ km/h}$

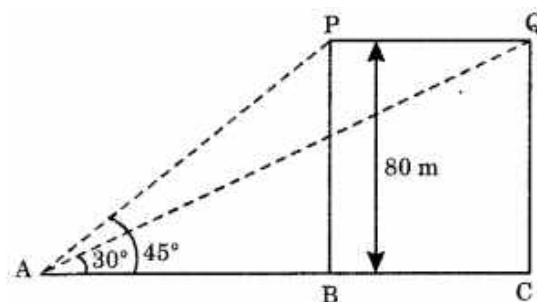
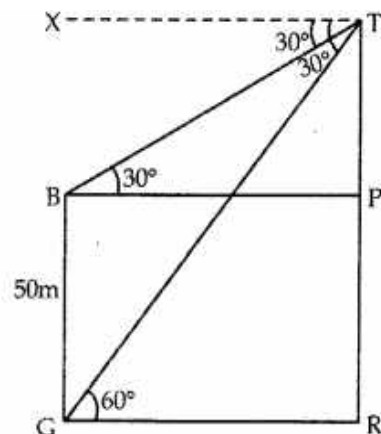

### CASE BASED QUESTIONS (4 MARKS QUESTIONS)

1. A group of students of class X visited India Gate on an education trip. The teacher and students had interest in history as well. The teacher narrated that India Gate, official name Delhi Memorial, originally called All-India War Memorial, monumental sandstone arch in New Delhi, dedicated to the troops of British India who died in wars fought between 1914 and 1919. The teacher also said that India Gate, which is located at the eastern end of the Rajpath (formerly called the Kingsway), is about 138 feet (42 metres) in height

(i) What is the angle of elevation if they are standing at a distance of 42m away from the monument?

Solution:  $45^\circ$

(ii) Find the length of the shadow cast by the India Gate if the elevation of the Sun is at  $60^\circ$ ?

Solution:  $14\sqrt{3}$  m

(iii)(a) The ratio of the length of the India Gate and its shadow is 1:1. The angle of elevation of the Sun is

Solution:  $45^\circ$



(OR)

(iii)(b) Find the length of a ladder placed 42m away from the base of the India Gate such that its top just touches the tip of the monument ?

Solution:  $\sim 60$ m

2. A Satellite flying at height  $h$  is watching the top of the two tallest mountains in Uttarakhand and Karnataka, them being Nanda Devi (height 7,816m) and Mullayanagiri (height 1,930 m). The angles of depression from the satellite, to the top of Nanda Devi and Mullayanagiri are  $30^\circ$  and  $60^\circ$  respectively. If the distance between the peaks of the two mountains is 1937 km, and the satellite is vertically above the midpoint of the distance between the two mountains.

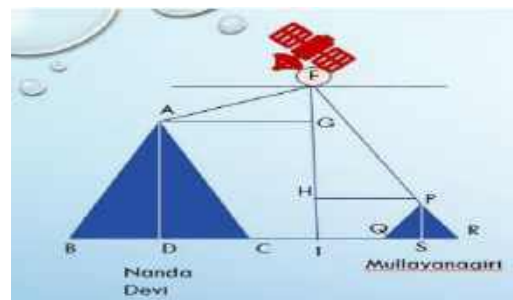

(i) Find the distance of the satellite from the top of Nanda Devi?

Solution: 1139.4 km

(ii) Find the distance of the satellite from the top of Mullayanagiri?

Solution: 1937 km

(iii)(a) What is the angle of elevation if a man is standing at a distance of 7816m from Nanda Devi?

Solution:  $45^\circ$

(OR)

(iii)(b) If a mile stone very far away from, makes  $45^\circ$  to the top of Mullanyangiri mountain. So, find the distance of this mile stone from the mountain.

Solution: 1937 km

3. A drone was used to facilitate movement of an ambulance on the straight highway to a point P on the ground where there was an accident. The ambulance was travelling at the speed of 60 km/h. The drone stopped at a point Q, 100 m vertically above the point P. The angle of depression of the ambulance was found to be  $30^\circ$  at a particular instant.

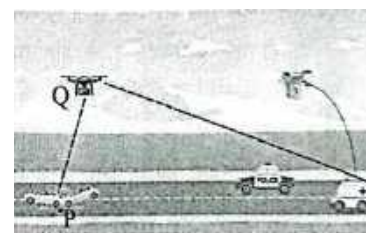

Based on above information, answer the following questions :

(i) Represent the above situation with the help of a diagram.

(ii) Find the distance between the ambulance and the site of accident (P) at the particular instant, (Use  $\sqrt{3}=1.73$ )

Solution: Solution: The distance between the ambulance and the accident site is 173m

(iii)(a) Find the time (in seconds) in which the angle of depression changes from  $30^\circ$  to  $45^\circ$ .

Solution: The time in which the angle of depression changes from  $30^\circ$  to  $45^\circ$  is 4.38 sec

(OR)

(iii)(b) How long (in seconds) will the ambulance take to reach point P from a point T on the highway such that angle of depression of the ambulance at T is  $60^\circ$  from the drone?

Solution: The time it takes for the ambulance to reach point P from point T is 6.91 sec

**HOTS ( HIGH ORDER THINKING SKILLS)**

1. From an aeroplane vertically above a straight horizontal plane, the angles of depression of two consecutive kilometres stones on the opposite sides of the aeroplane are found to be  $\alpha$  and  $\beta$ . Show that the height of the aeroplane is  $\frac{\tan\alpha\tan\beta}{\tan\alpha+\tan\beta}$

Solution: Let A be the aeroplane and its height be h km further, let B and C be two consecutive kilometres stone so that distance  $BC = 1$  km.

Let  $BD = x$  km

Then  $DC = (1 - x)$  km

In  $\triangle ABD$ ,

$$\tan \alpha = \frac{AD}{BD} = \frac{h}{x} \Rightarrow x = \frac{h}{\tan \alpha} \dots (i)$$

In  $\triangle ADC$ ,

$$\tan \beta = \frac{AD}{DC} = \frac{h}{1-x} \dots (ii)$$

$$\Rightarrow h = \tan \beta \left(1 - \frac{h}{\tan \alpha}\right)$$

From (i) and (ii)

$$h = \tan \alpha \tan \beta - \frac{h \tan \beta}{\tan \alpha} \Rightarrow h(\tan \alpha + \tan \beta) = \tan \alpha \tan \beta \Rightarrow h = \frac{\tan \alpha \tan \beta}{\tan \alpha + \tan \beta}$$

2. A spherical balloon of radius r subtends an angle  $\theta$  at the eye of an observer. If the angle of elevation of its centre is  $S$ , find the height of the centre of the balloon.

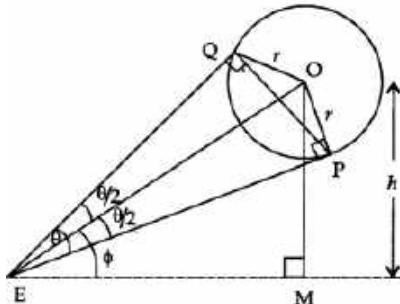

Solution: Let O be the centre of the balloon of radius r.  $OP = r$ . Let E be the eye of an observer so that angle subtended by balloon at the eye E is  $\angle PEQ = \theta$  and angle of elevation of centre of balloon =  $\angle OEM = \Phi$

Let the height of the centre of balloon be h i.e.,  $OM = h$ ,

Let  $OE = d$

$$\therefore \angle PEO = \angle QEO = \frac{\theta}{2}$$

Now, as radius is perpendicular to the tangent at point of contact .

$$\therefore \angle OPE = 90^\circ$$

So,  $\triangle OPE$  is right angled at P and  $\triangle OME$  is right angled at M.

$$\text{In right } \triangle OPE, \sin \left(\frac{\theta}{2}\right) = \frac{OP}{OE} = \frac{r}{d}$$

In  $\triangle OME$ ,

$$\sin \Phi = \frac{OM}{OE} = \frac{h}{d}$$

$$\frac{\sin \sin (\Phi)}{\sin \sin \left(\frac{\theta}{2}\right)} = \frac{h}{r}$$

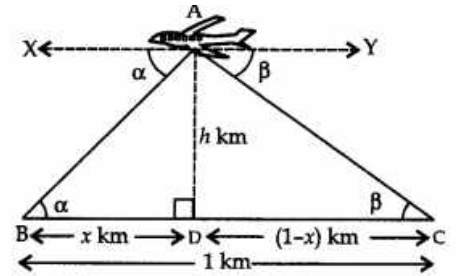

$$\Rightarrow h = r \sin \Phi \operatorname{cosec} \left( \frac{\theta}{2} \right)$$

Hence, the height of centre of the balloon is  $r \sin \Phi \operatorname{cosec} \left( \frac{\theta}{2} \right)$ .

3. At the foot of a mountain the elevation of its summit is  $45^\circ$ , after ascending 1000 m towards the mountain up a slope of  $30^\circ$  inclination, the elevation is found to be  $60^\circ$ . Find the height of the mountain.

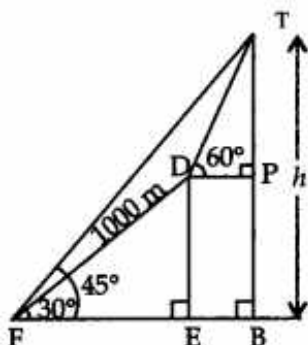

Solution: Let F be the foot and T be the summit of the mountain TFH such that  $\angle TFH = 45^\circ$

$\therefore$  In right  $\triangle TBF$ ,  $\angle BTF = 90^\circ - 45^\circ = 45^\circ$

Let height of mountain be h i.e.,  $TB = h$

since  $\angle TFH = \angle BTF = 45^\circ \Rightarrow BF = BT = h$

$\angle DFE = 30^\circ$  and  $FD = 1000$  m,  $\angle TDP = 60^\circ$

Draw  $DE \perp BF$  and  $DP \perp BT$

In right  $\triangle DEF$ ,  $\cos 30^\circ = \frac{FE}{DF} \Rightarrow \frac{\sqrt{3}}{2} = \frac{FE}{1000} \Rightarrow FE = 500\sqrt{3}$  m

Also  $\sin 30^\circ = \frac{DE}{DF} \Rightarrow \frac{1}{2} = \frac{DE}{1000} \Rightarrow DE = 500$  m

$\therefore BP = DE \Rightarrow BF = 500$  m

Now  $TP = TB - BP = h - 500$

In  $\triangle TPD$ ,  $\cos 60^\circ = \frac{DP}{TP} \Rightarrow DP = \frac{h-500}{\sqrt{3}}$

Now,  $BF = BE + EF = DP + EF$

In  $\triangle TBF$ ,  $\tan 45^\circ = \frac{TB}{BF} \Rightarrow TB = BF = DP + EF$

$h = \frac{h-500}{\sqrt{3}} + 500\sqrt{3} = \frac{h-500+1500}{\sqrt{3}} = \frac{h+1000}{\sqrt{3}}$

$\sqrt{3}h - h = 1000 = h(1.732 - 1) = 1000$

$h = \frac{1000}{0.732} = 1366$  m

# CHAPTER – 10

## CIRCLES

### MIND MAP

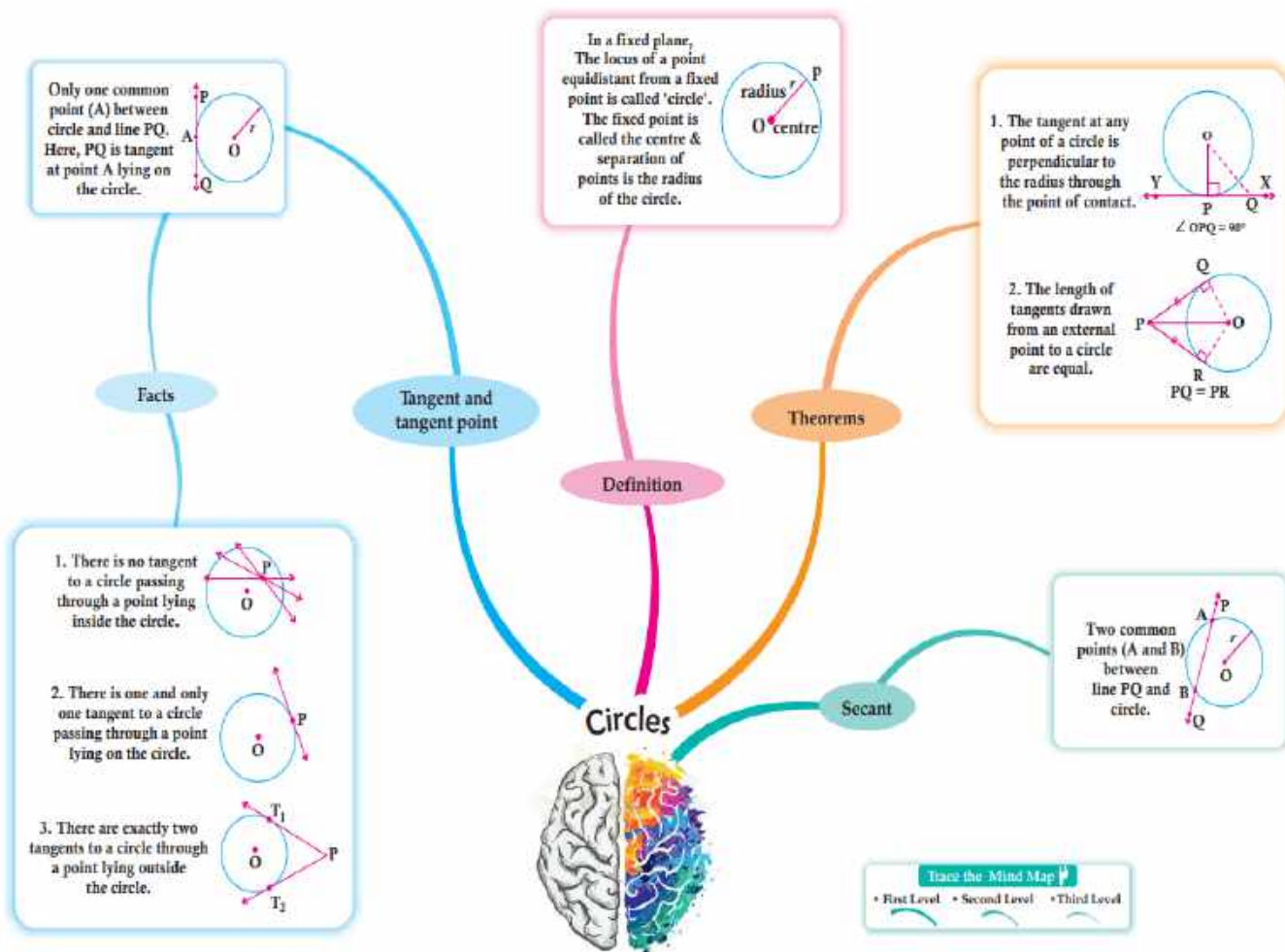

### GIST OF THE CHAPTER :-

- (1) Introduction
- (2) Tangents to a circle
- (3) The tangent at any point of a circle is perpendicular to the radius through the point of contact.
- (4) Number of Tangents from a Point on a Circle
- (5) The lengths of tangents drawn from an external point to a circle are equal.

### DEFINITIONS :-

- (1) **Circle** :- A circle is a collection of all points in a plane which are at a constant distance (radius) from a fixed point (centre)
- (2) **Chord** :- The chord is the line segment having its two end points lying on the circumference of the circle.
- (3) **Secant** :- A secant to a circle is a line that intersects the circle at exactly two points.

A line PQ is called a secant.

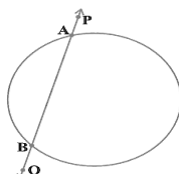

**NOTE :-** A secant to a circle is a line whereas a chord of a circle is a line segment whose end points lie on a circle.

(4) **Tangent to a circle** :- A tangent to a circle is a line that intersects the circle at only one point.

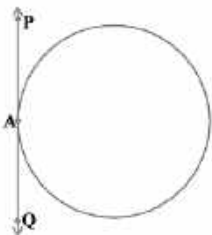

A line PQ is called a tangent to a circle.

(5) **Point of Contact** :- The common point of the tangent and the circle is called the point of contact. In the above figure the point A is called the point of contact.

**NOTE** :- (i) There is only one tangent at a point of the circle. There are infinitely many points on a circle, so a circle can have infinitely many tangents.

(ii) The tangent to a circle is a special case of the secant, when the two end points of its corresponding chord coincides.

(iii) A circle can have two (2) parallel tangents at the most.

(6) **Theorems** :-

**Theorem 10.1** :- The tangent at any point of a circle is perpendicular to the radius through the point of contact.

**Given** :- A circle with centre O and a tangent XY to the circle at a point P.

**To Prove** :-  $OP \perp XY$

**Construction** :- Take a point Q on XY other than P and join OQ. Suppose OQ meets the circle at R

**Proof** :- Among all line segments joining the point O to a point on XY, the shortest one is perpendicular to XY. So, to prove that  $OP \perp XY$ , it is sufficient to prove that OP is shorter than any other segment joining O to any point of XY.

Clearly  $OP = OR$ . [radii of the same circle]

Now,  $OQ = OR + RQ$

$\Rightarrow OQ > OR$

$\Rightarrow OQ > OP$  ( $\because OP = OR$ )

Thus, OP is shorter than any other segment joining O to any point of XY.

Hence,  $OP \perp XY$ .

**Theorem 10.2** :- The lengths of tangents drawn from an external point to a circle are equal.

**Given** :- A circle with centre O, a point P lying outside the circle and two tangents PQ, PR on the circle from P

**To Prove** :-  $PQ = PR$

**Construction** :- Join OP, OQ and OR

**Proof** :- In  $\Delta PQO$  and  $\Delta PRO$

$\angle PQO = \angle PRO = 90^\circ$  [ radius is perpendicular to the tangent at the point of contact ]

$PO = PO$  [ Common side ]

$OQ = OR$  [radii of the same circle]

$\Delta PQO \cong \Delta PRO$  [ by RHS congruence rule ]

$PQ = PR$  [ CPCT ]

**Number of tangents from a point on a circle :-**

(i) There is no tangent to a circle passing through a point lying inside the circle.



(ii) There is one and only one tangent to a circle passing through a point lying on the circle.

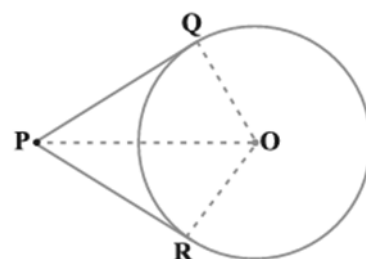
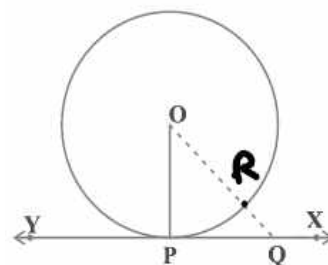

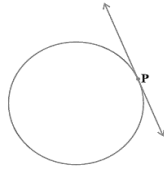

(iii) There are exactly two tangents to a circle through a point lying outside the circle.

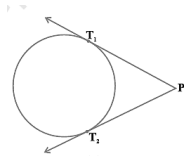

(7) **Length of the tangent** : The length of the segment of the tangent from the external point P and the point of contact with the circle is called the length of the tangent from the point P to the circle.

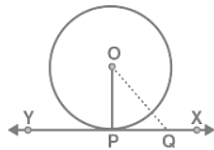

- (8) In right triangle OPQ,  $\angle OPQ = 90^\circ$ , OQ is the hypotenuse then  
 (i)  $OQ^2 = OP^2 + PQ^2$       (ii)  $OP^2 = OQ^2 - PQ^2$       (iii)  $PQ^2 = OQ^2 - OP^2$
- (9) In the given figure TP, TQ are two tangents drawn from an external point T.

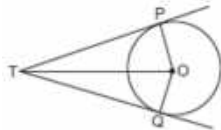

- (i) TO bisects angle PTQ and angle POQ      (ii)  $\angle PTQ + \angle POQ = 180^\circ$

**MULTIPLE CHOICE QUESTIONS(1 MARK QUESTIONS)**

- (1) Two parallel lines touch the circle at points A and B respectively. If area of the circle is  $25 \pi \text{ cm}^2$ , then AB is equal to  
 (a) 5 cm      (b) 8 cm      (c) 10 cm      (d) 25 cm  
 Ans) (c) Area of a circle  $= \pi r^2 = 25 \pi \Rightarrow r = 5 \text{ cm}$ , Distance AB = 10 cm
- (2) In the given figure PQ is tangent then  $\angle POQ + \angle QPO$  is  
 (a)  $180^\circ$       (b)  $45^\circ$       (c) more than  $90^\circ$       (d)  $90^\circ$   
 Ans) (d) We know that a radius is perpendicular to the tangent at the point of contact, so  $\angle PQO = 90^\circ$   
 In  $\Delta PQO$ , by ASP of a triangle,  $\angle POQ + \angle QPO = 90^\circ$
- (3) In the given figure, ABC is circumscribing a circle, then the length of BC is  
 (a) 4 cm      (b) 8 cm      (c) 9 cm      (d) 5 cm  
 Ans) (c)  
 The lengths of the tangents drawn from an external point to a circle are equal.  
 $BN = BL = 4 \text{ cm}$ ,  $AN = AM = 3 \text{ cm}$ ,  $CL = CM = 8 - 3 = 5 \text{ cm}$   
 $BC = BL + CL = 4 + 5 = 9 \text{ cm}$ .
- (4) In the given figure, a tangent has been drawn at a point P on the circle centred at O. If  $\angle TPQ = 110^\circ$  then  $\angle POQ$  is equal to  
 (a)  $110^\circ$       (b)  $70^\circ$       (c)  $140^\circ$       (d)  $55^\circ$   
 Ans) (c) We know that  $OP \perp TP$ ,  $\angle OPQ = 110^\circ - 90^\circ = 20^\circ$   
 Since,  $OP = OQ$ , so  $\angle OPQ = \angle OQP = 20^\circ$   
 By ASP of a triangle  $\angle POQ = 180^\circ - (20 + 20) = 180^\circ - 40^\circ = 140^\circ$

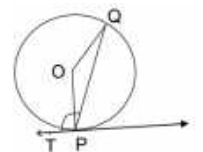
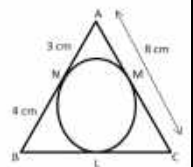
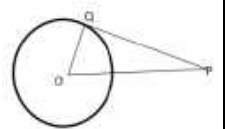

(5) In the given figure, PQ and PR are tangents to a circle centred at O. If  $\angle QPR = 35^\circ$  then  $\angle QOP$  is equal to

- (a)  $72.5^\circ$  (b)  $73.5^\circ$  (c)  $135^\circ$  (d)  $145^\circ$

Ans) (a)  $\angle QPR + \angle QOR = 180^\circ$ ,  $\angle QOR = 180^\circ - 35^\circ = 145^\circ$

PO bisects  $\angle QOR$  so,  $\angle QOP = \frac{1}{2} \angle QOR = 72.5^\circ$

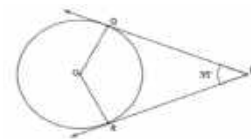

(6) If perimeter of given triangle is 38 cm, then length AP is equal to

- (a) 19 cm (b) 5 cm (c) 10 cm (d) 8 cm

Ans) Let  $AP = AQ = x$

$$2x + 12 + 16 = 38 \text{ cm} \quad 2x = 38 - 28 = 10 \text{ cm} \quad x = \frac{10}{2} = 5 \text{ cm}$$

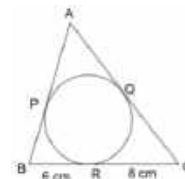

(7) In figure, AP, AQ and BC are tangents to the circle. If  $AB = 5$  cm,  $AC = 6$  cm and  $BC = 4$  cm, then the length of AP (in cm) is

- (a) 15 (b) 7.5 (c) 20 (d) 30

Ans) (b)  $AP + AQ = \text{Perimeter of } \triangle ABC$ ,  $AP = \frac{1}{2} (\text{Perimeter of } \triangle ABC) = 7.5$  cm

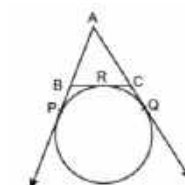

(8) If two tangents inclined at an angle  $60^\circ$  are drawn to a circle of radius 3 cm, then length of each tangent is equal to

- (a)  $(3/2)\sqrt{3}$  cm (b) 6 cm (c) 3 cm (d)  $3\sqrt{3}$  cm

Ans) (d) OP bisects  $\angle APB \Rightarrow \angle APO = \frac{60^\circ}{2} = 30^\circ$ , In rt  $\triangle OAP$ ,  $\tan 30^\circ = \frac{OA}{AP}$

$$\Rightarrow \frac{1}{\sqrt{3}} = \frac{3}{AP} \Rightarrow AP = 3\sqrt{3} \text{ cm}$$

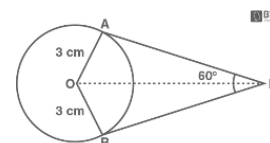

(9) In the figure below, PQ is a chord of a circle and PT is the tangent at P such that  $\angle QPT = 60^\circ$ .

Then  $\angle PRQ$  is equal to

- (a)  $135^\circ$  (b)  $150^\circ$  (c)  $120^\circ$  (d)  $110^\circ$

Ans) (c) From the given,  $\angle QPT = 60^\circ$  and  $\angle OPT = 90^\circ$

Thus,  $\angle OPQ = \angle OQP = 30^\circ$ , i.e.,  $\angle POQ = 120^\circ$ .

Also,  $\angle PRQ = \frac{1}{2} \times \text{reflex } \angle POQ$ ,  $\text{reflex } \angle POQ = 360^\circ - 120^\circ = 240^\circ$

Therefore,  $\angle PRQ = \frac{1}{2} \times 240^\circ = 120^\circ$

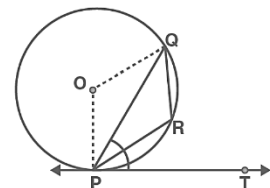

(10) In the figure, PQL and PRM are tangents to the circle with centre O at the points Q and R, respectively and S is a point on the circle such that  $\angle SQL = 50^\circ$  and  $\angle SRM = 60^\circ$ . Then  $\angle QSR$  is equal to

- (a)  $40^\circ$  (b)  $60^\circ$  (c)  $70^\circ$  (d)  $80^\circ$

Ans) (c) From the given,

$$\angle OSQ = \angle OQS = 90^\circ - 50^\circ = 40^\circ$$

$$\text{and } \angle RSO = \angle SRO = 90^\circ - 60^\circ = 30^\circ$$

Therefore,  $\angle QSR = 40^\circ + 30^\circ = 70^\circ$ .

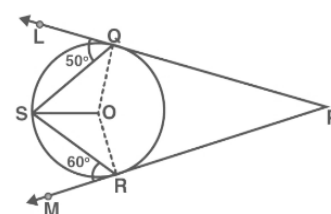

### ASSERTION REASON BASED QUESTION

**DIRECTION:** In the following questions, a statement of **Assertion (A)** is followed by a statement of **Reason (R)**. Choose the correct option

- (a) Both assertion (A) and reason (R) are true and reason (R) is the correct explanation of assertion (A)  
 (b) Both assertion (A) and reason (R) are true and reason (R) is not the correct explanation of assertion (A)  
 (c) Assertion (A) is true but reason (R) is false.  
 (d) Assertion (A) is false but reason (R) is true.

(1) **Assertion(A):** If length of a tangent from an external point to a circle is 8 cm, then length of the other tangent from the same point is 8 cm.

**Reason(R):** length of the tangents drawn from an external point to a circle are equal.

Ans) (a)

(2) **Assertion(A):** The length of the tangent drawn from a point at a distance of 13 cm from the centre of a circle of radius 5 cm is 10 cm.

**Reason(R):** A tangent to a circle is perpendicular to the radius through the point of contact.

Ans) (d) length of the tangent = 12 cm

(3) **Assertion(A):** PA and PB are tangents drawn from an external point P to a circle with centre O such that  $\angle APB = 40^\circ$ , then  $\angle AOB = 170^\circ$ .

**Reason(R):** The angle between the two tangents drawn from an external point at a circle are supplementary to the angle subtended by the line segments joining the points of contact at the centre.

Ans) (d)

(4) **Assertion(A):** If the radius of a circle is 5 cm then the distance between parallel tangents is 10 cm

**Reason (R) :** The radius of a circle is perpendicular to the tangent at the point of contact.

Ans) (b)

(5) **Assertion (A):** If two tangents are drawn to a circle from an external point, then the angles between the tangents and the chord joining the points of contact are equal.

**Reason (R):** The tangents drawn from an external point to a circle are always equal in length.

Ans) (a)

(6) **Assertion (A):** The tangents drawn at the ends of a diameter of a circle are parallel.

**Reason (R):** The angle between the tangent and the radius at the point of contact is  $90^\circ$

Ans) (a)

(7) **Assertion (A):** In the below figure, AB and CD are common tangents to circles which touch each other at D. If AB = 8 cm, then the length of CD is 4 cm.

**Reason (R):** The tangents drawn from an external point to a circle are always equal in length.

Ans) (a)

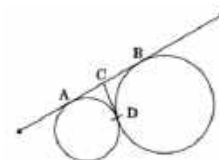

(8) **Assertion(A):** If PA and PB are tangents drawn from an external point P to a circle with centre O, then the quadrilateral AOBP is cyclic.

**Reason(R):** The angle between the two tangents drawn from an external point at a circle are supplementary to the angle subtended by the line segments joining the points of contact at the centre.

Ans) (a)

(9) **Assertion(A):** In figure, PA and PB are tangents drawn from an external point P to a circle with centre O such that  $\angle APB = 40^\circ$ . If C is a point on the circle, then  $\angle ACB = 70^\circ$ .

**Reason (R):** The angle subtended by an arc at the centre is double to the angle subtended by it at any point on the remaining part of the circle

Ans) (a)

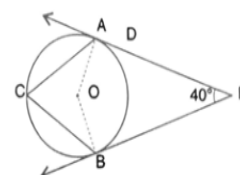

(10) **Assertion:** A tangent to a circle is perpendicular to the radius through the point of contact.

**Reason:** The lengths of tangents drawn from an external point to a circle is equal.

Ans)(b)

### **VERY SHORT ANSWER TYPE QUESTIONS (2 MARKS QUESTIONS)**

(1) In figure, a circle touches all the four sides of a quadrilateral ABCD whose sides are AB = 6 cm, BC = 9 cm and CD = 8 cm. Find the length of side AD.

Ans)  $AD + BC = AB + DC \Rightarrow AD = 5$  cm

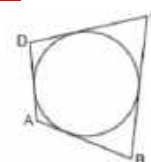

(2) In the given figure, if  $AB = AC$ , prove that  $BE = EC$ .

Ans) Given that  $AB = AC \Rightarrow AD + DB = AF + FC \Rightarrow AD + DB = AD + FC$  (tangents from an external point are equal)  
 $DB = FC \Rightarrow BE = EC$  (tangents from an external point are equal)

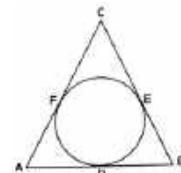

(3) In figure if  $\angle ATO = 40^\circ$ , find  $\angle AOB$ .

Ans)  $\angle ATB = 2 \times 40 = 80^\circ$ ,  $\angle AOB = 180^\circ - 80^\circ = 100^\circ$

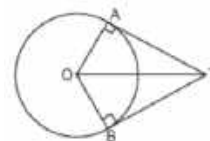

(4) In figure, common tangents AB and CD to the two circles  $O_1$  and  $O_2$  intersect at E. Prove that  $AB = CD$ .

Ans)  $EA = EC$  and  $EB = ED \Rightarrow EA + EB = EC + ED \Rightarrow AB = CD$

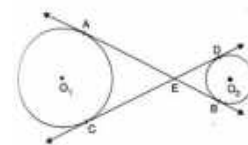

(5) In given figure, AB is the diameter of a circle with centre O and AT is a tangent. If  $\angle AOQ = 58^\circ$ , find  $\angle ATB$ .

Ans)  $\angle ABQ = \frac{1}{2} \times 58 = 29^\circ$   
 $\angle BAT = 90^\circ$ ,  $\angle ATB = 180^\circ - (90 + 29) = 61^\circ$

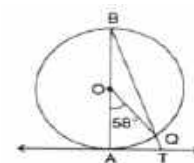

(6) In the given figure, PA and PB are two tangents drawn from an external point P to a circle with centre C and radius 4 cm. If  $PA \perp PB$ , then find the length of each tangent.

Ans) Join CA and CB, then CAPB is a square.  $PA = PB = 4$  cm.

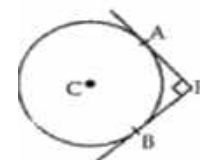

(7) Two concentric circles are of radii 7 cm and r cm respectively, where  $r > 7$  cm. A chord of the larger circle, of length 48 cm, touches the smaller circle.

Find the value of r.

Ans)  $AC = BC = 24$  cm, By using Pythagoras theorem,  $OA = r = 25$  cm

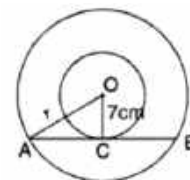

(8) In the given figure, PQ is a tangent at a point C to a circle with centre O. If AB is a diameter and  $\angle CAB = 30^\circ$ . Find  $\angle PCA$ .

Ans) Join OC,  $OA = OC \Rightarrow \angle OAC = \angle OCA = 30^\circ$   
 $\angle PCA = 90^\circ - 30^\circ = 60^\circ$

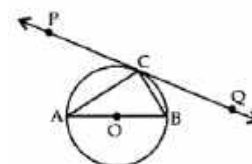

(9) In figure, CP and CQ are tangents to a circle with centre O. ARB is another tangent touching the circle at R. If  $CP = 11$  cm, and  $BC = 7$  cm, then find the length of BR.

Ans)  $CQ = CP = 11$  cm  $\Rightarrow CB + BQ = 11$  cm  $\Rightarrow CB + BR = 11$  cm  $\Rightarrow$   
 $BR = 11$  cm  $- 7$  cm  $= 4$  cm.

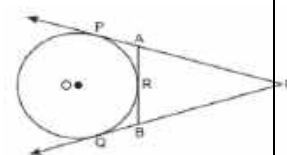

(10) Find the perimeter (in cm) of a square circumscribing a circle of radius 'a' cm.

Ans) Radius = R

$AB = a + a = 2a$

$\therefore$  Perimeter  $= 4(AB) = 4(2a) = 8a$  cm

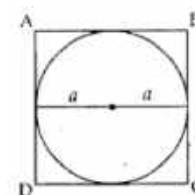

### SHORT ANSWER TYPE OF QUESTIONS (3 MARKS QUESTIONS)

(1) Two tangents TP and TQ are drawn to a circle with centre O from an external point T. Prove that  $\angle PTQ = 2 \angle OPQ$ .

Ans) Let  $\angle PTQ = x$ , Now,  $TP = TQ$ . So TPQ is an isosceles triangle.

Therefore,  $\angle TPQ = \angle TQP = \frac{1}{2} (180^\circ - x) = 90^\circ - \frac{1}{2} x$  and  $\angle OPT = 90^\circ$

$\angle OPQ = \angle OPT - \angle TPQ = 90^\circ - (90^\circ - \frac{1}{2} x) = \frac{1}{2} x = \frac{1}{2} \angle PTQ$ ,

$\angle PTQ = 2 \angle OPQ$

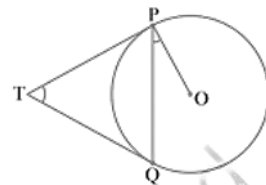

(2) In a right triangle ABC, right-angled at B,  $BC = 12$  cm and  $AB = 5$  cm. Calculate the radius of the circle inscribed in the triangle (in cm).

Ans)  $AC = 13$  cm, (By Pythagoras theorem)

Area of  $\triangle ABC =$  Area of  $\triangle AOB +$  ar. of  $\triangle BOC +$  ar. of  $\triangle AOC$

$$60 = r (AB + BC + AC)$$

$$60 = 30r \Rightarrow r = 2 \text{ cm}$$

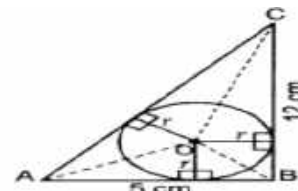

(3) In the figure, AP and BP are tangents to a circle with centre O, such that  $AP = 5$  cm and  $\angle APB = 60^\circ$ . Find the length of chord AB.

Ans)  $PA = PB$  ... [Tangents drawn from an external point are equal]

$$\Rightarrow \angle PAB = \angle PBA = \angle APB = 60^\circ$$

$\therefore$  APAB is an equilateral triangle

Hence,  $AB = AP = 5$  cm ... [  $\because$  All sides of an equilateral triangle are equal ]

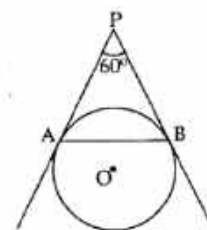

(4) In the figure, a circle is inscribed in a triangle PQR with  $PQ = 10$  cm,  $QR = 8$  cm and  $PR = 12$  cm. Find the lengths of QM, RN and PL.

Ans) Let  $PL = PN = x$  cm,  $QL = QM = y$  cm,  $RN = MR = z$  cm

$$PQ = 10 \text{ cm} = x + y = 10 \dots (i), \quad QR = 8 \text{ cm} = y + z = 8 \dots (ii)$$

$$PR = 12 \text{ cm} = x + z = 12 \dots (iii)$$

By adding (i), (ii) and (iii),

$$2x + 2y + 2z = 10 + 8 + 12 \Rightarrow 2(x + y + z) = 30$$

$$\Rightarrow x + y + z = 15 \Rightarrow 10 + z = 15 \dots [\text{From (i)}]$$

$$\therefore z = 15 - 10 = 5 \text{ cm}, \quad y = 3 \text{ cm}, \quad x = 7 \text{ cm}$$

$QM = 3$  cm,  $RN = 5$  cm and  $PL = 7$  cm

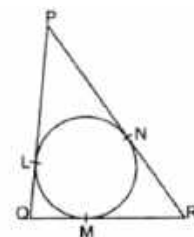

(5) A corporation of Amaravathi city has allocated a parallelogram ABCD shaped land to construct a circular cricket stadium touching all the sides of ABCD to BCCI. Show that ABCD is a rhombus and find its area if  $AC = 2.5$  km and  $BD = 3.2$  km.

Ans) ABCD is a  $\parallel^{\text{gm}}$

$AP = AS$ ,  $BP = BQ$ ,  $CR = CQ$ ,  $DR = DS$  [ By known theorem ]

By adding the above we get  $AB + DC = AD + BC \Rightarrow 2 AB = 2 BC$

$$\Rightarrow AB = BC$$

Therefore, ABCD is a rhombus.

Area of rhombus =  $\frac{1}{2} \times$  product of diagonals =  $\frac{1}{2} \times 2.5 \times 3.2 = 4 \text{ sq km}$ .

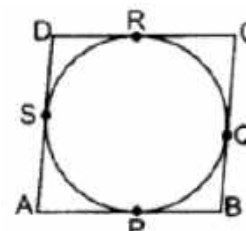

(6) In figure, there are two concentric circles, with centre O and of radii 5 cm and 3 cm. From an external point P, tangents PA and PB are drawn to these circles. If  $AP = 12$  cm, find the length of BP.

Ans) Join OA, OB and OP

By Pythagoras theorem,  $OP = 13$  cm.  $BP = \sqrt{169 - 9} = \sqrt{160} = 4\sqrt{10}$  cm.

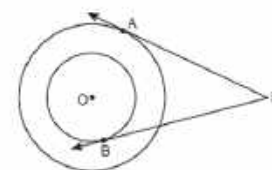

(7) In the below figure, find the actual length of sides of  $\triangle OTP$

Ans) By using Pythagoras theorem,  $OP^2 = OT^2 + TP^2$  we get  $x^2 - 14x + 33 = 0$

By solving the equation we get  $x = 11$  and  $x = 3$  (rejected)

$OP = 13$  cm,  $OT = 5$  cm,  $TP = 12$  cm

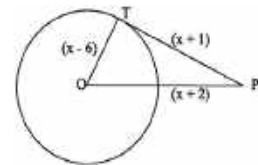

(8) In the given figure TAS is a tangent to the circle, with centre O, at the point A. If  $\angle OBA = 32^\circ$ , find the value of x and y.

Ans)  $\angle OBA = \angle OAB = 32^\circ$ ;  $x = 90^\circ - 32^\circ = 58^\circ$

$$y = \frac{1}{2} \times \angle AOB = 58^\circ$$

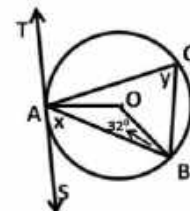

(9) If AB is a chord of a circle with centre O, AOC is a diameter and AT is the tangent at A as shown in Fig. Prove that  $\angle BAT = \angle ACB$

Ans)  $\angle ABC = 90^\circ$  (angle in a semi-circle)

$$\angle ACB = 90^\circ - \angle BAC \dots (1) \quad \angle BAT = 90^\circ - \angle BAC \dots (2)$$

From (1) and (2) we get  $\angle BAT = \angle ACB$

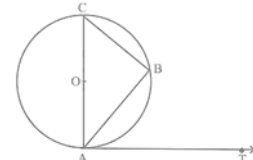

(10) At one end A of a diameter AB of a circle of radius 5 cm, tangent XAY is drawn to the circle. Find the length of the chord CD parallel to XY and at a distance 8 cm from A.

Ans) A chord CD is drawn which is parallel to XY and at a distance of 8 cm from A.

Now,  $\angle OAY = 90^\circ$

[ $\because$  Tangent at any point of circle is perpendicular to the radius through the point of contact]

Now, in right angled  $\triangle OEC$ ,

$$OC^2 = OE^2 + EC^2 \text{ [By Pythagoras theorem]} \Rightarrow EC^2 = OC^2 - OE^2$$

$$\Rightarrow EC^2 = 5^2 - 3^2$$

$$\Rightarrow EC^2 = 25 - 9 = 16$$

$$\Rightarrow EC = 4 \text{ cm}$$

$$CD = 2 \times EC \Rightarrow CD = 2 \times 4 \Rightarrow CD = 8 \text{ cm}$$

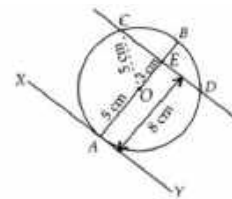

### LONG ANSWER TYPE QUESTIONS ( 5 MARKS QUESTIONS)

(1) (a) Prove that the lengths of tangents drawn from an external point to a circle are equal. (3M)

(b) In figure,  $\triangle ABC$  is circumscribing a circle. Find the length of BC. (2M)

Ans) (a) proof already given in the gist of lesson

$$(b) BP = BR = 3 \text{ cm and } CP = CQ = 11 - 4 = 7 \text{ cm}$$

$$BC = 7 + 3 = 10 \text{ cm.}$$

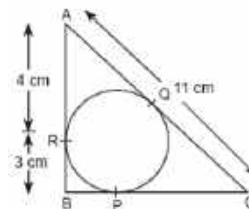

(2)(a) Prove that the radius of a circle is perpendicular to the tangent at the point of contact. (3M)

(b) In figure, AB is a chord of the circle and AOC is its diameter such that  $\angle ACB = 50^\circ$ . If AT is the tangent to the circle at the point A, then find  $\angle BAT$ .

Ans) (a) proof already given in the gist of lesson

$$(b) \angle ABC = 90^\circ$$

In  $\triangle ACB$ ,  $\angle A + \angle B + \angle C = 180^\circ$  [Angle sum property]

$$\Rightarrow \angle A + 90^\circ + 50^\circ = 180^\circ \Rightarrow \angle A + 140^\circ = 180^\circ \Rightarrow \angle OAB = 40^\circ$$

$$\angle BAT = 90^\circ - 40^\circ = 50^\circ$$

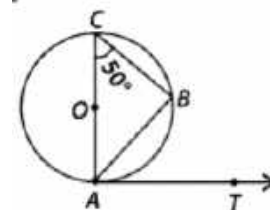

(3) In the figure, a  $\triangle ABC$  is drawn to circumscribe a circle of radius 3 cm, such that the segments BD and DC are respectively of lengths 6 cm and 9 cm. If the area of  $\triangle ABC$  is  $54 \text{ cm}^2$ , then find the lengths of sides AB and AC.

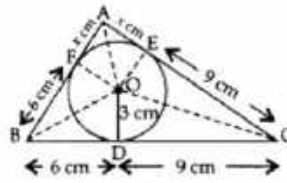
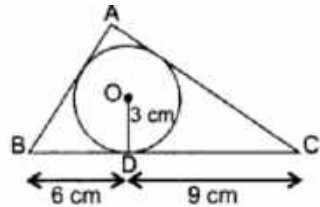

Ans) Given:  $OD = 3 \text{ cm}$ ;  $OE = 3 \text{ cm}$ ;  $OF = 3 \text{ cm}$

$$\text{ar}(\triangle ABC) = 54 \text{ cm}^2$$

Join :  $OA, OF, OE, OB$  and  $OC$

Let  $AF = AE = x$ ,  $BD = BF = 6 \text{ cm}$ ,  $CD = CE = 9 \text{ cm}$

$\therefore AB = AF + BF = x + 6 \dots(i)$   $AC = AE + CE = x + 9 \dots(ii)$   $BC = DB + CD = 6 + 9 = 15 \text{ cm}$   
 $\dots(iii)$

In  $\triangle ABC$ ,

$$\text{Area of } \triangle ABC = 54 \text{ cm}^2 \dots[\text{Given}] \quad \text{ar}(\triangle ABC) = \text{ar}(\triangle BOC) + \text{ar}(\triangle AOC) + \text{ar}(\triangle AOB)$$

$$x = 3, AB = 9 \text{ cm} \text{ and } AC = 12 \text{ cm.}$$

(4) In figure, two equal circles, with centres  $O$  and  $O'$ , touch each other at  $X$ .  $OO'$  produced meets the circle with centre  $O'$  at  $A$ .  $AC$  is tangent to the circle with centre  $O$ , at the point  $C$ .  $O'D$  is perpendicular to  $AC$ . Find the value of  $\frac{O'D}{OC}$ .

Ans)  $\angle ADO' = \angle ACO = 90^\circ$  and  $\angle DAO' = \angle CAO$  (common angle)

$$\triangle ADO' \sim \triangle ACO \quad \frac{DO'}{CO} = \frac{AO'}{AO}$$

$$\frac{DO'}{CO} = \frac{r}{3r} = \frac{1}{3}$$

(5) A circular region is inscribed in a triangular boundary as shown in figure. Each boundary of triangular part is act as tangent to the circle, where  $O$  is centre of circle and  $OD \perp BC$ . Answer the questions based on above

- What will be the radius of the circle, if  $BD = 24 \text{ cm}$  and  $OB = 25 \text{ cm}$ ?
- Determine  $CD$ , if  $OC = 26 \text{ cm}$ .
- As  $AB$  and  $AC$  act as tangents to the circle at  $E$  and  $F$  and  $AE = 8 \text{ cm}$ , then what is the perimeter of  $\triangle ABC$ .
- Determine area of  $\triangle BOC$ .
- What is the area of  $\triangle ABC$ ?

Ans) (a) By Pythagoras theorem,  $OD = 7 \text{ cm}$ .

$$(b) CD^2 = 676 - 49 = 627 \text{ cm}^2 \Rightarrow CD = 25.04 \text{ cm}$$

$$(c) \text{As } BD = BE \text{ and } CD = CF \Rightarrow BE = 24 \text{ cm}$$

$$CF = 25.04 \text{ cm} \quad AE = AF = 8 \text{ cm}$$

$$\text{Perimeter of } \triangle ABC = AB + BC + AC$$

$$= (AE + BE) + (BD + CD) + (AF + FC)$$

$$= (8 + 24) + (24 + 25.04) + (8 + 25.04) = 32 + 49.04 + 33.04 = 114.08 \text{ cm}$$

$$(d) \text{Area of } \triangle BOC = \frac{1}{2} \times BC \times OD = \frac{1}{2} (49.04) \times 7 = 171.64 \text{ cm}^2$$

$$(e) \text{Area of } \triangle ABC = \frac{1}{2} \times (\text{Perimeter of } \triangle ABC) \times \text{radius of circle} = \frac{1}{2} \times (114.08) \times 7 = 399.28 \text{ cm}^2$$

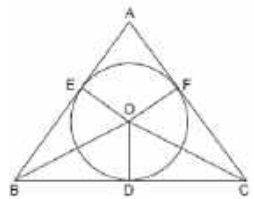
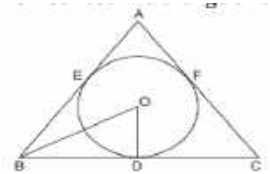
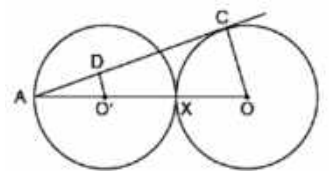

### CASE BASED QUESTIONS( 4 MARKS QUESTIONS )

(1) A student draws two circles that touch each other externally at point  $K$  with centres  $A$  and  $B$  and radii  $6 \text{ cm}$  and  $4 \text{ cm}$ , respectively as shown in the figure.

- How many common tangents can be drawn, if two circles touch externally
- Find the length of  $XY$
- (a) Find the sum of the areas of two circles (use  $\pi = 3.14$ )

(OR)

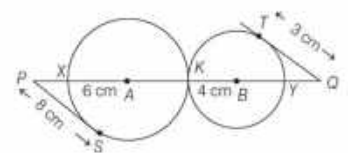

(b) Find the length of PQ

Ans) (i) 3 tangents

(ii) 20 cm

(iii)(a) Sum of the areas =  $\pi(R^2 + r^2) = 3.14(36 + 16) = 3.14 \times 52 = 163.28 \text{ cm}^2$

OR

(b) PA = 10 cm and QB = 5 cm (by Pythagoras theorem)

PQ = PA + AB + QB = 10 + 10 + 5 = 25 cm

(2) The picture given below shows a circular mirror hanging on the wall with a cord. The diagram represents the mirror as a circle with centre O. NA and NB are tangents to the circle at A and B respectively such that NA = 30 cm and  $\angle ANB = 60^\circ$ .

Based on above information answer the following

(i) Find the length of AB

(ii) Find  $m\angle AOB$

(iii)(a) Find the length of ON

(OR)

(a) Find the radius of the mirror.

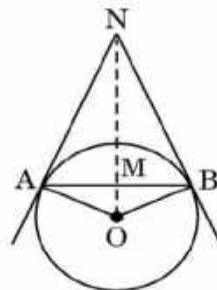

Ans) (i) In rt  $\triangle AMN$ ,  $\angle ANM = 30^\circ$

$\Rightarrow \tan 30^\circ = \frac{AM}{AN} \Rightarrow \frac{1}{\sqrt{3}} = \frac{AM}{30} \Rightarrow AM = 10\sqrt{3} \text{ cm}$  and  $AB = 20\sqrt{3} \text{ cm}$ .

(ii)  $\angle AOB = 120^\circ$

(iii)(a)  $\cos 30^\circ = \frac{AN}{ON} = \frac{\sqrt{3}}{2} = \frac{30}{ON}$

$ON = \frac{60}{\sqrt{3}} = 20\sqrt{3} \text{ cm}$

(OR)

(b)  $OA^2 = ON^2 - AN^2 = 1200 - 900 = 300 \Rightarrow OA = 10\sqrt{3} \text{ cm}$

(3) The discus throw is an event in which an athlete attempts to throw a discus. The athlete spins anti-clockwise around one and a half times through a circle, then releases the throw. When released, the discus travels along tangent to the circular spin orbit.

In the given figure, AB is one such tangent to a circle of radius 75 cm.

Point O is centre of the circle and  $\angle ABO = 30^\circ$ . PQ is parallel to OA

Based on the above, information:

(i) Find the length of AB.

(ii) Find the length of OB.

(iii) (a) Find the length of AP.

(OR)

(iii)(b) Find the length of PQ.

Ans: (i) use  $\tan 30^\circ$  ratio then  $AB = 75\sqrt{3} \text{ cm}$

(ii) use  $\sin 30^\circ$  ratio then  $OB = 150 \text{ cm}$

(iii)(a)  $QB = 150 - 75 = 75 \text{ cm} \Rightarrow Q$  is mid point. of OB Since

$PQ \parallel AO$  therefore P is mid point of AB

$AP = 37.5\sqrt{3} \text{ cm}$

(iii)(b)  $QB = 150 - 75 = 75 \text{ cm}$ .

$\triangle BQP \sim \triangle BOA$  (by AA similarity)  $\Rightarrow \frac{QB}{OB} = \frac{PQ}{AO}$

$\Rightarrow \frac{75}{150} = \frac{PQ}{75} \Rightarrow PQ = \frac{75}{2} \text{ cm}$ .

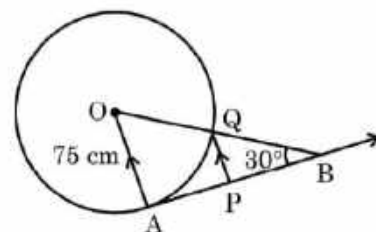

**HOTS(HIGH ORDER THINKING SKILLS)**

(1) In two concentric circles, the radii are  $OA = r$  cm and  $OQ = 6$  cm, as shown in the figure. Chord  $CD$  of larger circle is a tangent to smaller circle at  $Q$ .  $PA$  is tangent to larger circle. If  $PA = 16$  cm and  $OP = 20$  cm, find the length  $CD$ .

Ans)  $r^2 = 20^2 - 16^2 = 144 \Rightarrow r = 12$  cm  $\Rightarrow OD = r = 12$  cm

$DQ^2 = OD^2 - OQ^2 = 144 - 36 = 108 \Rightarrow DQ = 6\sqrt{3}$  cm  $\Rightarrow CD = 12\sqrt{3}$  cm .

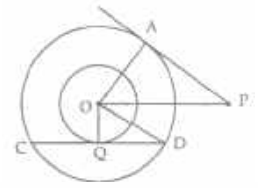

(2) In the following Fig,  $BOA$  is a diameter of a circle and the tangent at a point  $P$  meets  $BA$  extended at  $T$ . If  $\angle PBO = 30^\circ$ , then find  $\angle PTA$ .

Ans) As  $\angle BPA = 90^\circ$ ,  $\angle OBP = \angle OPB = 30^\circ$ ,  $\angle PAB = \angle OPA = 60^\circ$ .

Also,  $OP \perp PT$ . Therefore,  $\angle APT = 30^\circ$  and  $\angle PTA = 60^\circ - 30^\circ = 30^\circ$ .

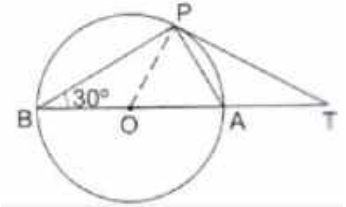

(3) If  $a, b, c$  are the sides of a right triangle where  $c$  is the hypotenuse, prove that the radius  $r$  of the circle which touches the sides of the triangle is given by  $r = \frac{a+b-c}{2}$

Ans) : Let the circle touches the sides  $BC, CA, AB$  of the right triangle  $ABC$  at  $D, E$  and  $F$  respectively,

where  $BC = a, CA = b$  and  $AB = c$  (see Fig.). Then  $AE = AF$  and  $BD = BF$ .

Also  $CE = CD = r$ . [  $OECF$  is a square ]

i.e.,  $b - r = AF, a - r = BF$  or  $AB = c = AF + BF = b - r + a - r$

$\Rightarrow c = a + b - 2r \Rightarrow 2r = a + b - c$

This gives  $r = \frac{a+b-c}{2}$

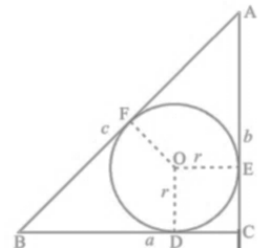

(4) In the following Fig.  $AB$  and  $CD$  are common tangents to two circles of unequal radii. Prove that  $AB = CD$ .

Ans) Produce  $AB$  and  $CD$  to intersect at  $P$ .

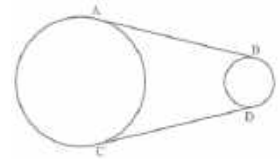

$PA = PC$  and  $PB = PD$

$\Rightarrow PA - PB = PC - PD \Rightarrow AB = CD$

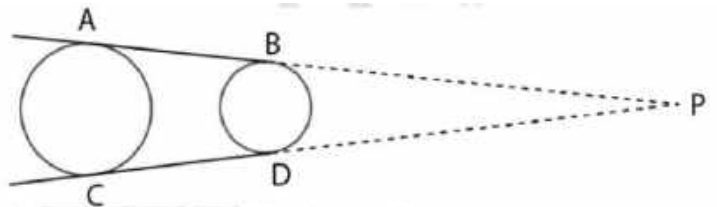

(5) In the figure, tangents  $PQ$  and  $PR$  are drawn from an external point  $P$  to a circle with centre  $O$ , such that  $\angle RPQ = 30^\circ$ . A chord  $RS$  is drawn parallel to the tangent  $PQ$ . Find  $\angle RQS$ .

Ans) Join  $OQ$  and  $OR$

$PR = PQ \Rightarrow$  In  $\Delta PQR$ ,  $\angle PRQ = \angle PQR = 75^\circ$

$\angle ROQ = 150^\circ \Rightarrow \angle QSR = \frac{1}{2} \angle QOR = 75^\circ$

$SR \parallel PQ$

$\Rightarrow \angle SRQ = \angle PQR = 75^\circ$  (alt. int. angles,  $QR$  is a transversal)

In  $\Delta QSR$ ,  $\angle RQS = 180^\circ - (\angle QSR + \angle SRQ) = 180^\circ - 150^\circ = 30^\circ$

$\angle RQS = 30^\circ$

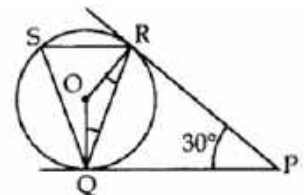
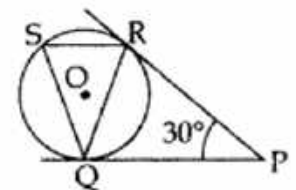

# CHAPTER : 11

## AREAS RELATED TO CIRCLES

### MIND MAP :

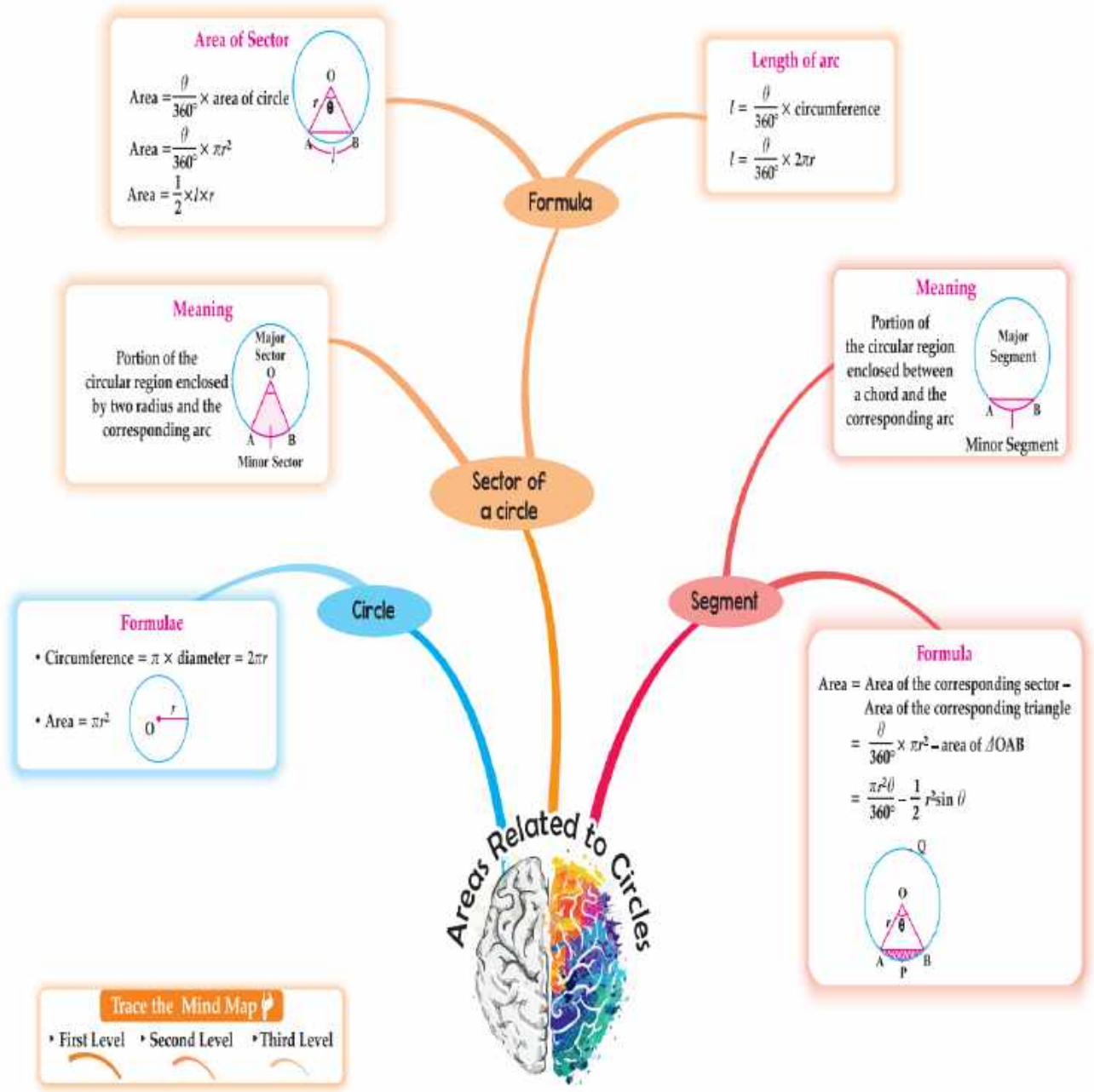

### GIST OF THE LESSON :-

- (1) Introduction to a circle and its related terms
- (2) Central angle or angle of a sector
- (3) Minor Sector (or a Sector) and Major Sector of a circle
- (4) Finding the area and perimeter of a Sector
- (5) Length of an arc of a sector
- (6) Area of minor segment and major segment.

### DEFINITIONS :-

- (1) Arc :- A continuous piece of a circle is called an arc of a circle

- (2) Chord :- A line segment whose end points lie on a circle is called a chord of a circle.
- (3) Central Angle :- An angle subtended by an arc at the centre of a circle is called its central angle.
- (4) Sector of a circle :- The portion (or part) of the circular region enclosed by two radii and the corresponding arc is called a sector of the circle  
 $\angle AOB = \theta$  is called central angle (or) angle of a sector

$OAPB$  is called minor sector or sector of a circle.

$OAQB$  is called a major sector

$APB$  is called an arc of a sector

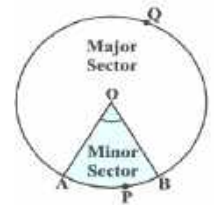

- (5) Segment of a circle :- The portion (or part) of the circular region enclosed between a chord and the corresponding arc is called a segment of the circle

$APB$  is a minor segment or segment of a circle

$AQB$  is called a major segment of a circle.

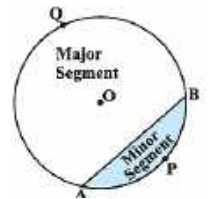

- (6) Quadrant of a circle :- One – fourth of a circle is called a quadrant of a circle.

The shaded portion AOB is called a quadrant of a circle. The central angle of a quadrant is  $90^\circ$ .

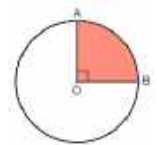

### **FORMULAE :-**

S.No.	Name	Figure	Perimeter	Area
1	Circle		$2\pi r$ or $\pi d$	$\pi r^2$
2	Semi - Circle		$\pi r + 2r$	$\frac{1}{2} \pi r^2$
3	Quarter of a circle		$\frac{1}{2} \pi r + 2r$	$\frac{1}{4} \pi r^2$
4	Right Triangle		Sum of the lengths of 3 sides	$\frac{1}{2} bh$
5	Equilateral Triangle		$3a$	$\frac{\sqrt{3}}{4} a^2$

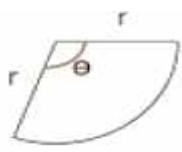
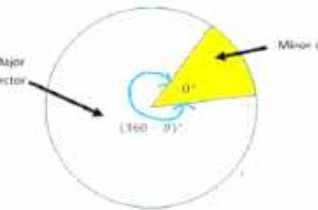
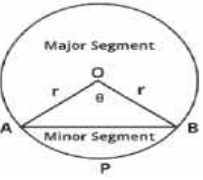
6	Sector of a Circle		Length of an Arc (l) $= \frac{\theta}{360} 2\pi r$ Perimeter = l + 2r	$\frac{\theta}{360} \pi r^2$ OR $\frac{1}{2} l r$
7	Major Sector		$(\frac{360-\theta}{360}) 2\pi r + 2r$	$\frac{(360 - \theta)^0}{360} \pi r^2$
8	Segment of a circle		$\frac{\theta}{180} \pi r + 2r \sin \frac{\theta}{2}$	$(\frac{\theta}{360} \pi r^2) - (\frac{1}{2} r^2 \sin \theta)$
9	Area of major segment = Area of a circle - Area of minor segment			
10	Number of rotations made by the wheel of a car = $\frac{\text{Distance travelled by the car}}{\text{Circumference of the wheel}}$			
11	$1 \text{ km/hr} = \frac{1000}{3600} = \frac{5 \text{ m}}{18 \text{ s}}$			
12	1 km = 1000 m and 1 hr = 3600 sec			
13	Minute hand : 60 minutes = 360° ⇒ 1 minute = 6° and Hour hand : 12 hours = 360° ⇒ 720 minutes = 360° ⇒ 1 minute = ( $\frac{1}{2}$ )° = half degree			

**NOTE :-** In the following figure, if  $\theta = 60^\circ$ , then the  $\Delta OAB$  is equilateral and  $AB = r$

If  $\theta = 90^\circ$  then the sector OAPB is a quadrant and  $\Delta OAB$  is a right triangle.

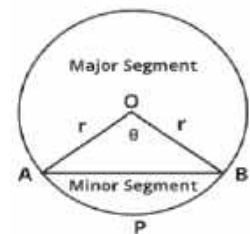

### **MULTIPLE CHOICE QUESTIONS( 1 MARK QUESTIONS)**

(1) In a sector of a circle of radius 21 cm, an arc subtends an angle of  $60^\circ$  at the centre. The length of the chord is:

- (a) 20cm                      (b) 21cm                      (c) 22cm                      (d) 25cm

Ans) (b) 21 cm

Solution:- If the central angle is  $60^\circ$ , then the triangle is equilateral. The length of the chord is

equal to its radius

- (2) The perimeter of the protractor if its radius 7cm is  
(a) 22 cm (b) 14 cm (c) 36 cm (d) 154 cm

Ans) (c) 36 cm

Solution:- Perimeter of the protractor =  $\pi r + 2r = (\frac{22}{7} \times 7) + (2 \times 7) = 22 + 14 = 36 \text{ cm}$

- (3) In figure, three sectors of a circle of radius 7 cm making angles of  $60^\circ$ ,  $80^\circ$  and  $40^\circ$  at the centre are shaded. The area of the shaded region is

- (a)  $154 \text{ cm}^2$  (b)  $77 \text{ cm}^2$  (c)  $120.5 \text{ cm}^2$  (d)  $180 \text{ cm}^2$

Ans) (b)  $77 \text{ cm}^2$

Solution:- Area of shaded region =  $\frac{(60+40+80)}{360} \times \pi r^2 = \frac{1}{2} \times \frac{22}{7} \times 7 \times 7 = 77 \text{ cm}^2$

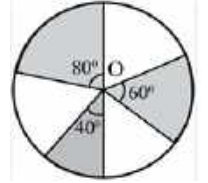

- (4) The perimeter of a sector of circle of radius 3.5 cm and sector angle  $60^\circ$  is

- (a)  $\frac{22}{6} \text{ cm}$  (b)  $\frac{29}{6}$  (c) 11 cm (d) 22 cm

Ans) (c) 11 cm

Solution: Perimeter of a sector = Length of an arc of a sector +  $2r = \frac{22}{6} + 2(3.5) = \frac{22}{6} + 7$

$$= \frac{66}{6} = 11 \text{ cm}$$

- (5) If the circumference of a circle and the perimeter of a square are equal, then

- (a) Area of the circle = Area of the square  
(b) Area of the circle > Area of the square  
(c) Area of the circle < Area of the square  
(d) Nothing definite can be said about the relation between the areas of the circle and square.

Ans) (b) Area of the circle > Area of the square

Solution :- According to the given condition,

$$2\pi r = 4a \Rightarrow r = \frac{7}{11} a$$

Area of a circle =  $\pi r^2 = \frac{14}{11} a^2$ , Area of a square =  $a^2 \Rightarrow$  Area of the circle > Area of the

square

- (6) In the fig, O is the centre of a circle. The area of sector OABP is  $\frac{5}{18}$  of the area of the circle. Then x is

- (a)  $50^\circ$  (b)  $70^\circ$  (c)  $100^\circ$  (d)  $110^\circ$

Ans) (c)  $100^\circ$

Solution :-  $\frac{x}{360} \pi r^2 = \frac{5}{18} \pi r^2 \Rightarrow x = \frac{5}{18} \times 360^\circ \Rightarrow x = 100^\circ$

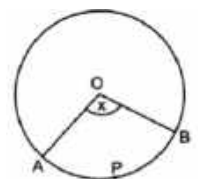

- (7) In a circle of radius 14 cm, an arc subtends an angle of  $30^\circ$  at the centre, the length of the arc is

- (a) 44 cm (b) 28 cm (c) 11 cm (d)  $\frac{22}{3} \text{ cm}$

Ans) (d)  $\frac{22}{3} \text{ cm}$

Solution :  $\frac{30}{360} \times 2 \times \frac{22}{7} \times 14 = \frac{22}{3} \text{ cm}$

- (8) The difference of the areas of a minor sector of angle  $120^\circ$  and its corresponding major sector of a circle of radius 21 cm, is

- (a)  $496 \text{ cm}^2$  (b)  $462 \text{ cm}^2$  (c)  $346.5 \text{ cm}^2$  (d)  $693 \text{ cm}^2$

Ans) (b)  $462 \text{ cm}^2$

Solution :-  $\frac{240}{360} \times \pi r^2 - \frac{120}{360} \pi r^2 = 21 \times 22 = 462 \text{ cm}^2$

(9) The length of the minute hand of a clock is 14 cm. The area swept by the minute hand in 5 minutes is

- (a) 153.9 cm<sup>2</sup>      (b) 102.6 cm<sup>2</sup>      (c) 51.3 cm<sup>2</sup>      (d) 205.2 cm<sup>2</sup>

Ans) (c) 51.3 cm<sup>2</sup>

$$\text{Solution : } \frac{30}{360} \times \pi r^2 = \frac{154}{3} = 51.3 \text{ cm}^2$$

(10) The area of the segment PAQ is

- (a)  $\frac{a^2}{4}(\pi+2)$       (b)  $\frac{a^2}{4}(\pi-2)$   
 (c)  $\frac{a^2}{4}(\pi+1)$       (d)  $\frac{a^2}{4}(\pi-1)$

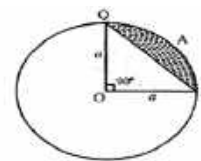

Ans) (b)  $\frac{a^2}{4}(\pi-2)$

### ASSERTION AND REASON BASED QUESTIONS

**DIRECTION:** In the following questions, a statement of **Assertion (A)** is followed by a statement of **Reason (R)**. Choose the correct option

(a) Both assertion **(A)** and reason **(R)** are true and reason **(R)** is the correct explanation of assertion **(A)**

(b) Both assertion **(A)** and reason **(R)** are true and reason **(R)** is not the correct explanation of assertion **(A)**

(c) Assertion **(A)** is true but reason **(R)** is false.

(d) Assertion **(A)** is false but reason **(R)** is true.

(1) **Assertion (A):** A horse is tied to a peg at one corner of a square shaped grass field of side 15 m by means of a 7 m long rope. The area of that part of the field in which the horse can graze is  $\frac{77}{2}$  sq.m.

**Reason (R) :** Area of the quadrant =  $\frac{90^\circ}{360^\circ} \pi r^2$

Ans) (a)

(2) **Assertion (A):** A boy is cycling such that the wheels of the cycle are making 70 revolutions per minute. If the diameter of the wheel is 20cm, then speed of the cycle is 88 m/minute.

**Reason (R):** Total distance travelled by the wheel =  $70 \times 2\pi r$

Ans) (d) The distance travelled = 4400 cm = 44 m

(3) **Assertion (A):** If a wire of length 22 cm is bent in the shape of a circle, then area of the circle so formed is 40 cm<sup>2</sup>

**Reason (R) :** Circumference of the circle = length of the wire

Ans)(d)

(4) **Assertion (A) :** If circumference of two circles are in the ratio 2 : 3 then ratio of their area is 4 : 9

**Reason (R) :** The circumference of a circle is  $2\pi r$  and its area is  $2\pi r^2$

Ans) (b)  $R = 2x$  and  $r = 3x$       Ratio of areas = 4 : 9

(5) **Assertion (A) :** In a circle of radius 6 cm, the angle of a sector  $60^\circ$ . Then area of sector is  $18\frac{6}{7}$  cm<sup>2</sup>

**Reason (R) :** Area of circle with radius r is  $\pi r^2$

Ans) (b)

(6) **Assertion (A):** If a square is inscribed in a circle, then the ratio of the areas of the circle and the square is  $\pi : 2$

**Reason (R):** If a square is inscribed in a circle of radius 'r' the diameter of circle is the diagonal of square and ratio of the areas of the circle and the square is  $\pi : 2$

Ans) (b)

(7) **Assertion (A):** If the sector angle is  $180^\circ$  then the area of a sector is  $\frac{1}{2} \pi r^2$

**Reason (R) :** If the sector angle is  $180^\circ$ , then the sector becomes a semicircle

Ans) (a)

(8) **Assertion (A)** : If the sector angle is  $90^\circ$  then the ratio of the areas of sector to a circle is 1 : 4

**Reason (R)** : One – fourth of a circle is called a quadrant

Ans) (b)

(9) **Assertion (A)** : If the circumference of a circle is doubled, then its area is doubled.

**Reason (R)** : The area of a circle of radius  $r$  is  $\pi r^2$

Ans) (d) as when we double the circumference area is quadrupled.

(10) **Assertion (A)** : The area of the largest triangle that can be, inscribed in a semicircle of radius  $r$  cm is  $r^2$  cm<sup>2</sup>

**Reason (R)** : Circumference of a circle is  $2\pi r$

Ans) (b)

**VERY SHORT ANSWER QUESTIONS (2 MARKS QUESTIONS)**

(1) In fig, OABC is a square of side 7 cm. If OAPC is quadrant of a circle with centre O, find the area of shaded region.

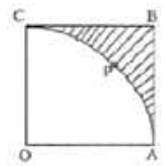

Ans) Area of shaded region = Area of a square – Area of a quadrant  
 $= 49 - 38.5 = 10.5 \text{ cm}^2$

(2) Find the area of a quadrant of a circle whose circumference is 44 cm.

Ans)  $2\pi r = 44 \Rightarrow r = 7 \text{ cm} \Rightarrow \text{Area of a quadrant} = \frac{1}{4} \pi r^2 = 38.5 \text{ cm}^2$

(3) Find the area of a sector of a circle of radius 5 cm, if the corresponding arc length is 3.5 cm.

Ans) Area of a sector =  $\frac{1}{2} \times \text{length of an arc} \times \text{radius} = \frac{1}{2} \times 3.5 \times 5 = 8.75 \text{ cm}^2$

(4) Shown below is a semicircular sheet of paper with centre O which is folded in half. A square of length 5 units is cut from it. What is the area of paper left.

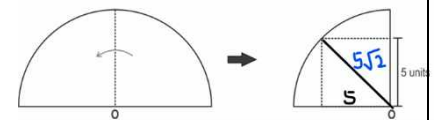

Ans) Radius of semicircle =  $5\sqrt{2}$  units

Area of paper left out =  $2[\text{Area of a quadrant} - \text{Area of a square}]$   
 $= 2 \left[ \frac{1}{2} \pi (25) - 25 \right]$   
 $= 25(\pi - 2) \text{ sq. units.}$

(5) The area of the sector of a circle of radius 10.5 cm is  $69.3 \text{ cm}^2$ . Find the central angle of the sector.

Ans)  $\frac{\theta}{360} \times \pi r^2 = 69.3 \Rightarrow \theta = 72^\circ$

(6) A sector of  $56^\circ$  cut out from a circle, contains area of  $17.6 \text{ cm}^2$ . Find the radius of the circle.

Ans)  $\frac{\theta}{360} \times \pi r^2 = 17.6 \Rightarrow r^2 = \frac{17.6 \times 360}{8 \times 22} \Rightarrow r = 6 \text{ cm}$

(7) A regular pentagon is inscribed in a circle with centre O, of radius 5 cm, as shown below. What is the area of the shaded part of the circle (find in terms of  $\pi$ )?

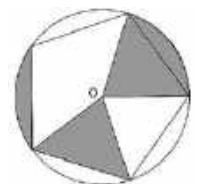

Ans) Central angle =  $\frac{360^\circ}{5} = 72^\circ$ , Area of the shaded part =  $2 \times \text{area of a sector}$   
 $= 2 \times \frac{72^\circ}{360^\circ} \times \pi \times 25 = 10\pi \text{ cm}^2$

(8) In the given figure ABCD is a trapezium, find the area of the shaded region.

(Use  $\pi = 3.14$ )

Ans)  $\angle BAD = 180^\circ - 60^\circ = 120^\circ$ ,

Area of shaded region =  $\frac{1}{3} \times 3.14 \times 9 = 3.14 \times 3 = 9.42 \text{ cm}^2$

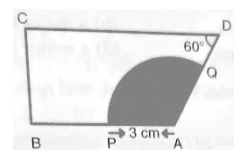

(9) The sum of the radii of two circles is 11cm and the difference of their circumference is 44cm. Find the radii of the circles.

Ans) Let the radii of two circles be R and r such that  $R > r$ ,  $R + r = 11$  ----- (1)

$$2\pi R - 2\pi r = 44 \Rightarrow 2\pi(R - r) = 44 \Rightarrow R - r = 7$$
 ----- (2)

Adding (1) and (2) we get,  $R = 9$  cm and  $r = 2$  cm

(10) The circumference of a circle exceeds its diameter by 45 cm. Find the radius of the circle (use  $\pi = 3.14$ )

Ans) Let the radius be r cm

$$2\pi r = 2r + 45 \Rightarrow 2r(\pi - 1) = 45 \Rightarrow r = \frac{45}{4.28} \Rightarrow r = 10.5 \text{ cm}$$

**SHORT ANSWER TYPE QUESTIONS (3 MARKS QUESTIONS)**

(1) Reeta made some designs for class room display board decoration as shown in fig, PQ and AB are respectively arcs of two concentric circles of radius 7 cm and 3.5 cm with centre O. If  $\angle POQ = 30^\circ$ , find the area of shaded region.

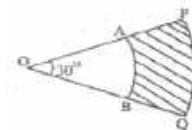

Ans) Area of the shaded part = Area of sector OPQ – Area of sector OAB = 9.625 cm<sup>2</sup>

(2) Ram has a square field circumscribing a circle of radius ‘a’ cm and perimeter of a field is 8a cm?

Is this statement true or false? Give reasons for your answer.

Ans) Side of square = Diameter of circle x AB = 2a

$$\text{So, the perimeter of square} = 4 \times AB = 4 \times 2a = 8a \text{ cm}$$

Hence, the given statement is true.

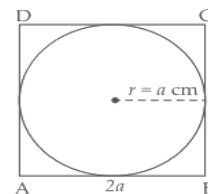

(3) In the given figure, arcs have been drawn with radii 14 cm each and with centres P, Q and R. Find the area of the shaded region.

Ans)  $\theta_1 + \theta_2 + \theta_3 = 180^\circ$  [Int. s of  $\Delta$ ]

$$\text{Area of shaded region} = \frac{180}{360} \times \frac{22}{7} \times 14 \times 14 = 308 \text{ cm}^2$$

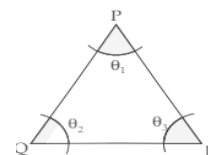

(4) The perimeter of a sector of a circle of radius 5.7m is 27.2m. Calculate:

(i) The length of arc of the sector in cm. (ii) The area of the sector in cm<sup>2</sup> correct to the nearest cm<sup>2</sup>

Ans) (i) Perimeter of a sector = length of an arc + 2r = 27.2 m

$$\Rightarrow \text{length of an arc} = 27.2 - 11.4 = 15.8 \text{ m} = 15.8 \times 100 \text{ cm} = 1580 \text{ cm}$$

$$(ii) \text{Area of a sector} = \frac{1}{2} \times \text{length of an arc} \times r = \frac{1}{2} \times 15.8 \times 5.7 = 45.03 \text{ m}^2 = 450300 \text{ cm}^2$$

(5) In a circle with centre O and radius 5 cm, AB is the chord of length  $5\sqrt{3}$  cm. Find the area of sector AOB. (Use  $\pi = 3.14$ )

Ans) Draw  $OM \perp AB \Rightarrow \sin \angle AOM = \frac{AM}{OA} = \frac{\sqrt{3}}{2} \Rightarrow \angle AOM = 60^\circ$

$$\Rightarrow \angle AOB = 120^\circ$$

$$\text{Area of sector AOB} = \frac{120}{360} \times 3.14 \times 25 = 26.17 \text{ cm}^2$$

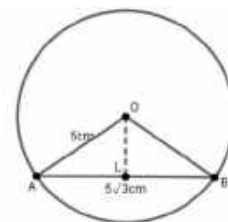

(6) The figure below is a part of a circle with centre O. Its area is  $\frac{1250}{9} \pi$  cm<sup>2</sup> and the 10 sectors are identical. Find the value of  $\beta$ .



Ans) 10 X area of a sector =  $\frac{1250}{9} \pi \Rightarrow \frac{\beta}{360} \pi \times 20 \times 20 = \frac{125}{9} \pi$

$$\beta = 12.5^\circ$$

(7) Find the area of the shaded field shown in the given figure.

Ans) Rectangle  $l = 8 \text{ m}$       Circle,  $r = 6 - 4 = 2 \text{ m}$   
 $b = 4 \text{ m}$

Area of shaded region = Area of rectangle + Area of semicircle

$$= (8 \times 4) + \frac{1}{2} \pi r^2 = (32 + 2\pi) \text{ m}^2$$

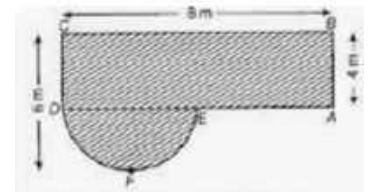

(8) A pendulum swings through an angle of one-third of a right angle and describes an arc 8.8 cm in length. Find length of the pendulum.

Ans)  $\theta = 30^\circ$ , length of an arc = 8.8 cm,  $r = ?$

$$r = \frac{8.8 \times 7 \times 12}{2 \times 22} \Rightarrow r = 16.8 \text{ cm}.$$

(9) Sneha had a rectangular tablecloth with one side measuring 30 cm which she wanted to keep on her circular table of radius 25 cm. After keeping it on the table, she realised that the corners of the tablecloth just touched the edge of the circular table as shown in the figure. Find the area of the table not covered by the tablecloth.

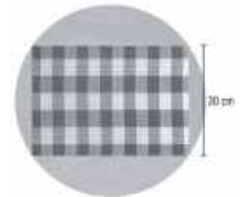

Show your steps with valid reasons. (Note: Use  $\pi = 3.14$ .)

Ans) Diagonal of the rectangle = Diameter of the circle = 50 cm.

$$(\text{Length of the rectangle})^2 = 2500 - 900 = (40)^2 = 40 \text{ cm}$$

$$\text{Area of a circle} = 1962.5 \text{ cm}^2 \quad \text{and Area of rectangle} = 1200 \text{ cm}^2$$

$$\text{Area of table not covered by towel} = 1962.5 - 1200 = 762.5 \text{ cm}^2$$

(10) A cow is tied at one of the corners of a square shed. The length of the rope is 22 m. The cow can only eat the grass outside the shed as shown below. What is the area that the cow can graze on? Show your steps. (Give the answer in terms of  $\pi$ )

Ans) Total area = 3 quarters sectors with radius 22 m + (2 x quarter sector with radius 2 m)

$$= \frac{3}{4} \pi \times 22 \times 22 + 2 \times \frac{1}{4} \pi \times 2 \times 2 = 363 \pi + 2\pi = 365 \pi \text{ m}^2$$

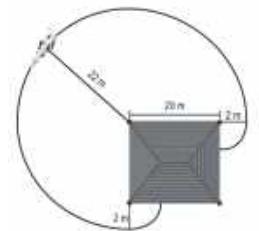

### LONG ANSWER TYPE QUESTIONS (5 MARKS QUESTIONS)

(1) A farmer has a field in the shape of a trapezium ABCD with  $AB \parallel DC$ ,  $AB = 18 \text{ cm}$ ,  $DC = 32 \text{ cm}$  and distance between AB and DC is 14 cm. If in 4 corners (arcs) of equal radii 7 cm with centres A, B, C and D have been drawn and grow different types of flowers, and in the remaining (shaded region) area he planned to grow wheat. Find the area of the field in which flowers and wheat can be grown.

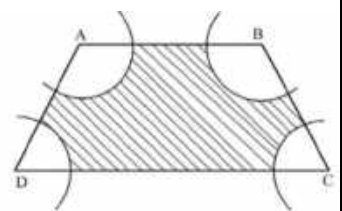

Sol) Area of the field in which wheat can be grown =

Area of a trapezium – Area of 4 sectors

$$\text{Area of a trapezium} = \frac{1}{2} \times (AB + DC) \times 14 = \frac{1}{2} \times 50 \times 14 = 350 \text{ cm}^2$$

$$\text{Area of flower bed (4 sectors)} = \frac{360^\circ}{360^\circ} \times \frac{22}{7} \times 7 \times 7 = 154 \text{ cm}^2$$

$$\text{Area in which wheat can be grown} = 350 - 154 = 196 \text{ cm}^2$$

(2) A child has made a design as shown in the figure. She has painted grey colour in the shaded portion where a circular arc of radius 6 cm has been drawn with vertex O of an equilateral triangle OAB of side 12 cm. Other than the shaded portion painted with white colour. Find the area of the grey and white coloured areas. (Use  $\sqrt{3} = 1.732$  and  $\pi = 3.14$ )

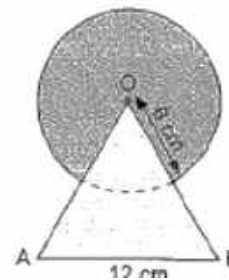

Ans) Area of the design painted with white colour = Area of triangle OAB

$$\text{Area of triangle OAB} = \frac{\sqrt{3}}{4} \times 12^2 = 62.352 \text{ cm}^2$$

Area of design painted with grey colour = Area of major sector

$$\text{Area of major sector} = \frac{300^\circ}{360^\circ} \times 3.14 \times 36 = 94.2 \text{ cm}^2$$

(3) An elastic belt is placed around the rim of a pulley of radius 5 cm as shown in the figure. From one point C on the belt, the elastic belt is pulled directly away from the centre O of the pulley until it is at P, 10 cm from the point O. Find the length of the belt that is still in contact with the pulley. Also, find the shaded area. (Use  $\pi = 3.14$  and  $\sqrt{3} = 1.73$ )

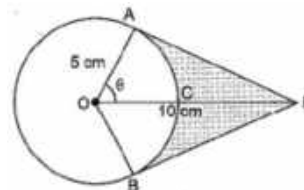

Ans) In right triangle OAP,  $\cos \theta = \frac{5}{10} = \frac{1}{2} \Rightarrow \theta = 60^\circ$

$$\angle AOB = 120^\circ \Rightarrow \text{reflex } \angle AOB = 240^\circ$$

the length of the belt that is in contact with the pulley =

$$\frac{240}{360} \times 2 \times 3.14 \times 5 = 20.93 \text{ cm}$$

$$\text{Length of PA} = 5\sqrt{3} \text{ cm} = \text{PB}$$

$$\text{Area of PAOB} = 2 \times \text{area of } \triangle PAO = 25\sqrt{3} = 43.25 \text{ cm}^2$$

$$\text{Area of OACB} = \frac{120}{360} \times 3.14 \times 25 = 26.17 \text{ cm}^2$$

$$\text{Area of shaded region} = 43.25 - 26.17 = 17.08 \text{ cm}^2$$

(4) In Figure, an equilateral triangle has been inscribed in a circle of radius 6 cm. Find area of the triangle

ABC and area of the three minor segments. (Use  $\pi = 3.14$  and  $\sqrt{3} = 1.73$ )

Ans) Area of a circle =  $\pi r^2 = 3.14 \times 36 = 113.04 \text{ cm}^2$

By drawing a perpendicular from A to BC and centre O of a circle divide the perpendicular in 2:1 ratio,  $AC = 6\sqrt{3} \text{ cm}$

$$\text{Area of a triangle ABC} = \frac{\sqrt{3}}{4} (6\sqrt{3})^2 = 46.71 \text{ cm}^2$$

$$\text{Area of three minor segments} = 113.04 - 46.71 = 66.33 \text{ cm}^2$$

(5) Find the perimeter and area of given figure, where AED is a semicircle and ABCD is a rectangle.

Ans) Length of an arc AED =  $\pi r = 22 \text{ cm}$

$$\text{Perimeter of the figure} = 14 + 20 + 20 + 22 = 76 \text{ cm}$$

Area of the figure = Area of the rectangle - Area of a semicircle

$$= (20 \times 14) - \frac{1}{2} \times \frac{22}{7} \times 7 \times 7 = 280 - 77 = 203 \text{ cm}^2$$

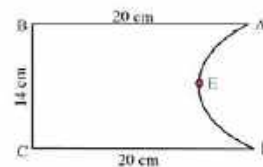

### CASE BASED QUESTIONS (4 MARKS QUESTIONS)

(1) A stable owner has four horses. He usually ties these horses with 7 m long rope to pegs at each corner of a square – shaped grass field of 20 m length, to graze in his farm. But tying with rope sometimes results in injuries to his horses, so he decided to build a fence around the area so that each horse could graze.

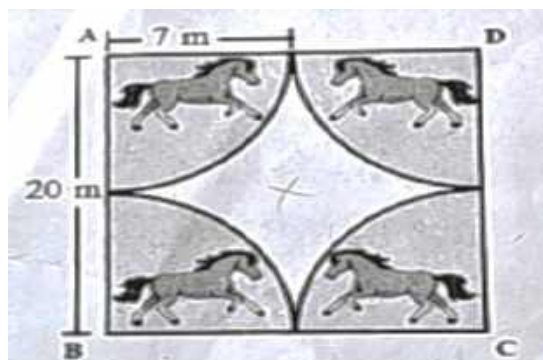

Based on the above information, answer the following questions.

(i) Find the area of the square shaped grass field

(ii)(a) Find the area of the total field in which these horses can graze

(OR)

(ii)(b) If the length of the rope of each rope is increased from 7 cm to 10 cm, find the area grazed by one Horse (Use  $\pi = 3.14$ )

(iii) What is the area of the field left ungrazed, if the length of the each rope of horse is 7 m

Ans) (i) Area of the square field =  $400 \text{ m}^2$

(ii)(a) Four quadrants makes one circle

The area of the field that horses can graze =  $\pi r^2 = 154 \text{ m}^2$

(OR)

(ii)(b) Area grazed by one horse =  $3.14 \times 100 = 314 \text{ m}^2$

(iii) Area left ungrazed by horses =  $400 - 154 = 246 \text{ m}^2$

(2) In Himachal Pradesh, World's longest highway tunnel opened which will reduce the distance between Manali to Leh by 46 km. It will connect Solang Valley near Manali to Sissu in Lahaul and Spiti district. It is named after the former Prime Minister Atal Bihari Vajpayee. At a length of 9.02 km, it is the longest tunnel above 10,000 feet in the world. The cross section of the tunnel is shown in the figure. The radius of the circular part is  $5\sqrt{2} \text{ m}$  and the central angle is  $90^\circ$ .

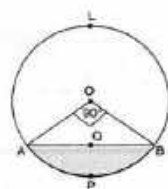

Based on the above information answer the following questions:

(i) Find the width of the tunnel?

(ii) Find the height of the tunnel?

(iii)(a) Find the area of the sector OAPB?

(OR)

(b) Find the area of the segment APBQ?

Ans) (i) Width of the tunnel =  $2 \times 5\sqrt{2} = 10\sqrt{2}$  m

(ii) The height of the tunnel =  $5\sqrt{2}$  m

(iii) (a) Area of sector OAPB =  $\frac{1}{4} \times 3.14 \times (5\sqrt{2})^2 = 39.25 \text{ m}^2$

(iii)(b) Area of APBQ =  $39.25 - \frac{1}{2} \times 25 \times 2 = 14.25 \text{ m}^2$

(3) Shown below is the trophy shield Akshi received on winning an international Table tennis tournament. The trophy is made of a glass sector DOC supported by identical wooden right triangles  $\Delta DAO$  and  $\Delta COB$ . Also,  $AO = 7$  cm and  $AO:DA = 1:\sqrt{3}$  (Use  $\sqrt{3}=1.73$ )

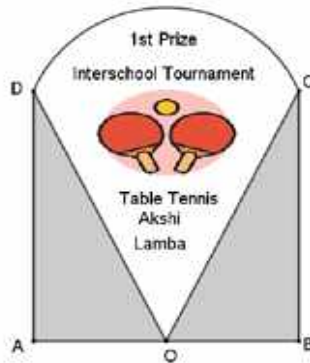

Based on the given information, answer the following questions:

(i) Find  $\angle DOC$

(ii) Find the area of the wooden triangles

(iii)(a) Find the area of the shape formed by the glass portion.

(OR)

(iii)(b) If Akshi wants to decorate the boundary of the glass portion with glitter tape, then find the length of the tape she needs.

Ans) (i) Let  $\angle DOA = \theta$ , then  $\tan \theta = \frac{AD}{AO} = \frac{\sqrt{3}}{1} \Rightarrow \theta = 60^\circ$ ,  $\angle DOA = \angle COB = 60^\circ$

$$\angle DOC = 180^\circ - (60^\circ + 60^\circ) = 60^\circ$$

(ii) Area of two wooden triangles =  $2 \times \frac{1}{2} \times 7 \times 7\sqrt{3} = 84.77 \text{ cm}^2$

(iii)  $\cos 60^\circ = \frac{AO}{DO} \Rightarrow \frac{1}{2} = \frac{7}{DO} \Rightarrow DO = 14 \text{ cm}$

$$\text{Area of sector } DOC = \frac{60}{360} \times \pi \times 14^2 = 102.67 \text{ cm}^2$$

(OR)

$$\text{Length of tape required} = 2 \times 14 + \frac{60}{360} \times 2 \times \pi \times 14 = 42.67 \text{ cm}$$

### HIGHER ORDER THINKING SKILLS

(1) In Figure, is shown a sector OAP of a circle with centre O, containing  $\angle \theta$ . AB is a perpendicular to the radius OA and meets OP produced at B. Prove that the perimeter of shaded region is

$$r \left[ \tan \theta + \sec \theta + \frac{\pi\theta}{180^\circ} - 1 \right]$$

Ans) Length of a minor arc AP =  $\frac{\theta}{180^\circ} \times \pi r$  ----- (i),  $\angle OAB = 90^\circ$

In rt.  $\triangle OAB$ ,  $\tan \theta = \frac{AB}{OA} \Rightarrow AB = OA \cdot \tan \theta \Rightarrow AB = r \tan \theta$  --(ii)

In rt.  $\triangle OAB$ ,  $\sec \theta = \frac{OB}{OA} \Rightarrow OB = OA \sec \theta \Rightarrow OB = r \sec \theta$

PB = OB - OP =  $r \sec \theta - r$  ----- (iii)

Perimeter of shaded region = AB + PB + AP

$$= r \tan \theta + r \sec \theta - r + \frac{\theta}{180^\circ} \times \pi r$$

$$= r \left[ \tan \theta + \sec \theta + \frac{\pi\theta}{180^\circ} - 1 \right]$$

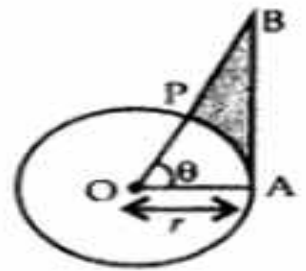

(2) Find the area of the square that can be inscribed in a circle of radius 8 cm.

Ans) Let the side of a square be 'x' cm  $\Rightarrow 2x^2 = 256$  cm  $\Rightarrow x^2 = 128$  cm<sup>2</sup>

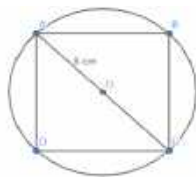

(3) In the given figure, a circle of radius 7.5 cm is inscribed in a square. Find the area of the shaded region (Use  $\pi = 3.14$ )

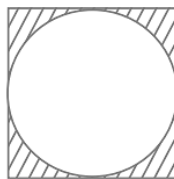

Ans) Area of the circle =  $\pi r^2 = 3.14 \times (7.5)^2$  cm<sup>2</sup> = 176.625 cm<sup>2</sup>

Clearly, side of the square = diameter of the circle = 15 cm

So, area of the square =  $15^2$  cm<sup>2</sup> = 225 cm<sup>2</sup>

Therefore, area of the shaded region =  $225$  cm<sup>2</sup> -  $176.625$  cm<sup>2</sup> =  $48.375$  cm<sup>2</sup>

(4) In the given figure, a circle is inscribed in a square of side 5 cm and another circle is circumscribing the square. Show that the area of the outer circle is two times the area of the inner circle?

Ans) : Diameter of the inner circle = 5 cm

and that of outer circle = diagonal of the square =  $5\sqrt{2}$  cm.

$$\frac{A_1}{A_2} = \frac{1}{2}$$

(5) In the given figure, the area of the shaded region between two concentric circles is 286 cm<sup>2</sup>. If the difference of the radii of the two circles is 7 cm, find the sum of their radii.

Ans) Equating area of shaded region  $\pi(R^2 - r^2) = 286$  cm<sup>2</sup> and

finding R=10cm and r=3cm

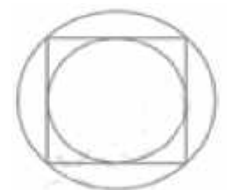
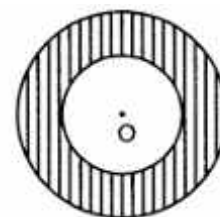

**CHAPTER 12**  
**SURFACE AREAS AND VOLUMES**  
**MIND MAP**

Name of solid	Volume	Total surface Area	Lateral surface Area
Cube	$V = a^3$	$TSA = 6a^2$	$LSA = 4a^2$
Cuboid	$V = l \times b \times h$	$TSA = 2(lb + bh + hl)$	$LSA = 2h(l + b)$
Cylinder	$V = \pi r^2 h$	$TSA = 2\pi r(h + r)$	$CSA = 2\pi rh$
Hollow cylinder ( $R > r$ )	$V = \pi(R^2 - r^2)h$	$TSA = 2\pi(R + r)(h + R - r)$	$2\pi(R+r)h$
Cone	$V = \frac{1}{3} \pi r^2 h$	$TSA = \pi r(l + r)$	$CSA = \pi rl$
Sphere	$V = \frac{4}{3} \pi r^3$	$TSA = 4\pi r^2$	$CSA = 4\pi r^2$
Hemisphere	$V = \frac{2}{3} \pi r^3$	$TSA = 3\pi r^2$	$CSA = 2\pi r^2$

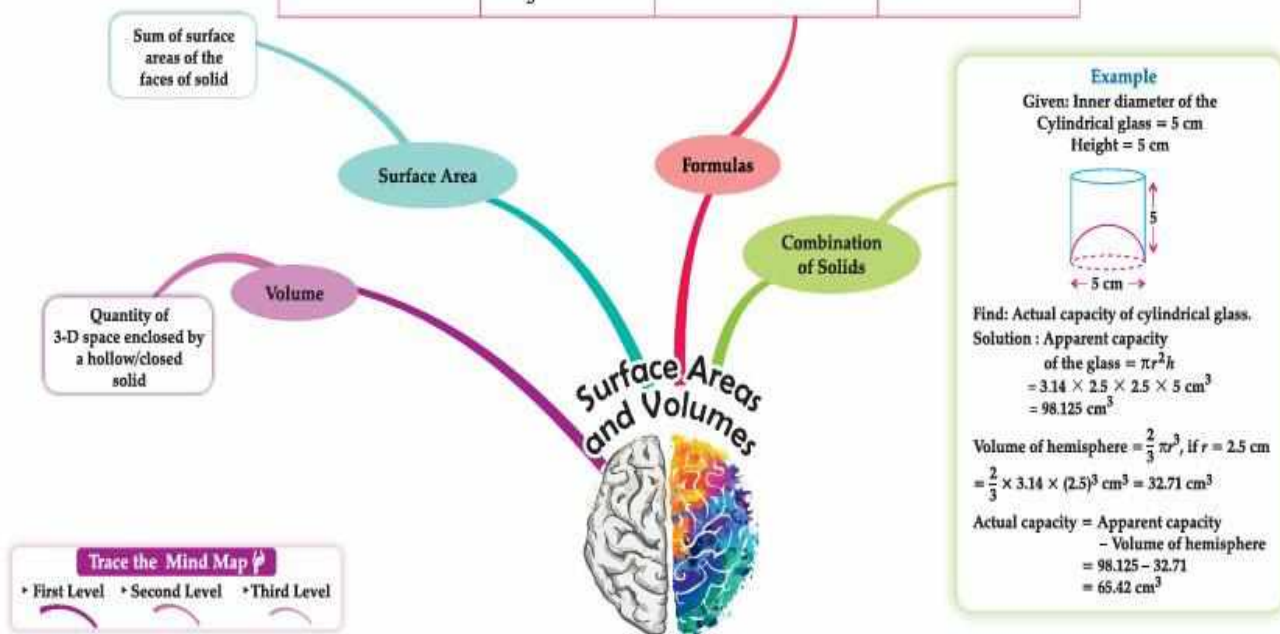

**Gist of the Chapter**

1. To determine the surface area of an object formed by combining any two of the basic solids, namely, cuboid, cone, cylinder, sphere and hemisphere.
2. To find the volume of objects formed by combining any two of a cuboid, cone, cylinder, sphere and hemisphere.
3. When two or more 3-D shapes are combined to form a new solid, then the surface area of the solid formed is the sum of areas of all its visible surfaces.
4. Volume of combination of solids depends on its shape. We add the volumes of the of individual shapes used in the solid or at times we subtract the volume of one solid shape from that of the other.

**MULTIPLE CHOICE QUESTIONS**

1. If the radius of cylinder is halved and height is doubled, then its curved surface area will  
(a) increase by 1      (b) be the same      (c) be doubled      (d) be tripled  
Ans. (b) be the same

Let  $r$  and  $h$  be the radius and height. New radius  $= \frac{r}{2}$  and height  $= 2h$

$$\text{New CSA} = 2\pi r h = 2 \times \pi \times \frac{r}{2} \times 2h = 2\pi r h$$

2. If a right circular cone has radius 4 cm and slant height 5 cm then its volume is

- (a)  $16\pi \text{ cm}^3$                       (b)  $14\pi \text{ cm}^3$                       (c)  $12\pi \text{ cm}^3$                       (d)  $18\pi \text{ cm}^3$

Ans. (a)  $16\pi \text{ cm}^3$

∴ slant height ( $l$ ) = 5cm and radius ( $r$ ) = 4 cm, its height ( $h$ ) =  $\sqrt{l^2 - r^2} = \sqrt{5^2 - 4^2} = 3\text{cm}$ .

$$\text{Volume} = \frac{1}{3}\pi r^2 h = \frac{1}{3}\pi \times 4^2 \times 3 = 16\pi \text{ cm}^3$$

3. If the radius of a sphere is doubled, then the ratio of the original and new surface areas is

- (a) 1 : 2                      (b) 2 : 1                      (c) 1 : 4                      (d) 4 : 1

Ans. (c) 1 : 4

Let  $r$  be radius of the sphere. Then the new radius  $= 2r$ .

$$\text{Ratio of original to the new surface areas} = 4\pi r^2 : 4\pi (2r)^2 = 4\pi r^2 : 16\pi r^2 = 1 : 4.$$

4. Two right circular cones have equal curved surface areas. Their slant heights are in the ratio of 3 :

5. Then the ratio of their radii is

- (a) 4 : 1                      (b) 3 : 5                      (c) 5 : 3                      (d) 4 : 5

Ans. (c) 5 : 3

Let the radii be  $r$  and  $R$  and slant heights be  $l$  and  $L$ . ratio of slant heights  $= \frac{l}{L} = 3 : 5$ .

$$\text{Given that } \pi r l = \pi R L. \Rightarrow \frac{r}{R} = \frac{L}{l} = 5 : 3.$$

5. In a cylindrical container of base radius is 8 cm has some water in it. If the level of the water is 20 cm the volume of the water in the container is

- (a) 5.6721                      (b) 4.0228                      (c) 3.8925                      (d) 4.971

Ans. (b) 4.0228

Here we need to find the volume of a cylinder of radius 8 cm and height 20 cm.

$$\text{Volume of water} = \pi r^2 h = \frac{22}{7} \times 8 \times 8 \times 20 \text{ cm}^3 = \frac{28160}{7} = 4022.85 \text{ cm}^3 = 4.0228 \text{ l}$$

1. If two solid hemispheres of same base radius are joined together along their bases, then the surface area of this new solid is

- (a)  $3\pi r^2$                       (b)  $4\pi r^2$                       (c)  $5\pi r^2$                       (d)  $6\pi r^2$

Ans. (b)  $4\pi r^2$

When two hemispheres of the same radii are joined the new solid would be a sphere.

7. The sum of the length, breadth and height of a cuboid is  $6\sqrt{3}\text{cm}$  and the length of its diagonal is  $2\sqrt{3}\text{cm}$ . The total surface area of the cuboid is

- (a)  $48\text{cm}^2$                       (b)  $72 \text{ cm}^2$                       (c)  $96 \text{ cm}^2$                       (d)  $108 \text{ cm}^2$ .

Ans. (c)  $96 \text{ cm}^2$

$$\text{Given } (l + b + h) = 6\sqrt{3}\text{cm. diagonal of a cuboid} = \sqrt{l^2 + b^2 + h^2} = 2\sqrt{3}$$

$$l^2 + b^2 + h^2 = 12.$$

$$\text{TSA} = 2(lb + bh + hl) = (l + b + h)^2 - (l^2 + b^2 + h^2) = (6\sqrt{3})^2 - 12 = 108 - 12 = 96 \text{ cm}^2$$

8. A vessel is in the shape of a cylinder of height 7 cm mounted on a hemisphere of radius 0.07m. Its inner surface area is \_\_\_\_  $\text{cm}^2$ .

- (a) 700                      (b) 600                      (c) 516                      (d) 616

Ans. (d) 616

The inner surface area of the Vessel = CSA of the cylinder + CSA of the hemisphere

$$= 2\pi r h + 2\pi r^2 = 2\pi r (h + r) = 2 \times \frac{22}{7} \times 7 \times (7 + 7)$$

$$= 616 \text{ cm}^2 \quad [0.07 \text{ m} = 7 \text{ cm}]$$

9. The volume of a solid hemi sphere is  $\frac{396}{7} \text{ cm}^3$ . Its total surface area is \_\_\_\_\_  $\text{cm}^2$ .

- (a)  $\frac{396}{7}$                       (b)  $\frac{594}{7}$                       (c)  $\frac{549}{7}$                       (d)  $\frac{604}{7}$

Ans. (b)  $\frac{594}{7}$

$$\text{Volume of hemisphere} = \frac{2}{3} \pi r^3 = \frac{396}{7} \text{ cm}^3 \Rightarrow \frac{2}{3} \times \frac{22}{7} r^3 = \frac{396}{7} \Rightarrow r^3 = \frac{396}{7} \times \frac{7}{22} \times \frac{3}{2} \Rightarrow r = 3$$

$$\text{So, TSA} = 3 \pi r^2 = 3 \times \frac{22}{7} \times 9 = \frac{594}{7} \text{ cm}^3$$

10. A rectangular sheet of paper 40cm x 22cm, is rolled to form a hollow cylinder of height 40cm. The radius of the cylinder (in cm) is:

- (a) 3.5                      (b) 7                      (c) 80/7                      (d) 5

Ans. (a) 3.5

Here the breadth of the rectangular paper = base perimeter of cylinder = 22cm.

$$2 \pi r = 22 \text{ cm.} \Rightarrow 2 \times \frac{22}{7} \times r = 22 \text{ cm.} \Rightarrow r = \frac{7}{2} = 3.5 \text{ cm.}$$

### ASSERTION AND REASONING TYPE QUESTIONS

**DIRECTION:** In the following questions, a statement of **Assertion (A)** is followed by a statement of **Reason (R)**. Choose the correct option

- (a) Both assertion (A) and reason (R) are true and reason (R) is the correct explanation of assertion (A)
- (b) Both assertion (A) and reason (R) are true and reason (R) is not the correct explanation of assertion (A)
- (c) Assertion (A) is true but reason (R) is false.
- (d) Assertion (A) is false but reason (R) is true.

1. **Assertion (A):** Total Surface area of the top is the sum of the curved surface area of the hemisphere and the curved surface area of the cone.

**Reason (R):** Top is made by fixing the plane surfaces of the hemisphere and cone together.

Ans: (a)

2. **Assertion (A):** The total surface area of a cube of side 5 cm is 150  $\text{cm}^2$ .

**Reason (R):** The formula for the total surface area of a cube is  $6a^2$ , where 'a' is its side.

Ans: (a)

3. **Assertion (A):** If both radius and height of a cone are doubled, then its volume becomes 4 times

**Reason (R):** Volume of a cone =  $\frac{1}{3} \pi r^2 h$ .

Ans: (d)

4. **Assertion (A):** If the diameter of a sphere is halved, its surface area becomes one-fourth.

**Reason (R):** Surface area of a sphere is proportional to the square of the radius.

Ans: (a)

5. **Assertion (A):** A conical vessel of base radius 5cm and height 24cm is full of water and it is emptied into a cylindrical vessel of radius 10 cm, then the water level rises by 2 cm.

**Reason (R):** Volume of a cone is one third that of a of cylinder having same base radius and height.

Ans: (a)

Volume of conical vessel = volume of water in the cylindrical vessel.

6. **Assertion (A):** If a right circular cylinder of radius r and height h ( $h > 2r$ ) just encloses a sphere then the diameter of the sphere is 2r

**Reason (R):** The surface area of a sphere is  $2\pi r(h+r)$

Ans: (c)

2. **Assertion (A):** Three cubes of volume 8 cubic cm. are joined end to end then the surface area of the resulting cuboid is  $72 \text{ cm}^2$

**Reason (R):** The surface area of a cuboid is  $2(lb + bh + hl)$ .

Ans: (a)

[ Volume of cube =  $a^3 = 8 \Rightarrow a = 2 \text{ cm}$ . So, for the cuboid,  $l = 8 \text{ cm}$ ,  $b = 2 \text{ cm}$  and  $h = 2 \text{ cm}$ .

Surface area =  $2(8 \times 2 + 2 \times 2 + 2 \times 8) = 2(16+4+16) = 72 \text{ cm}^2$ .]

8. **Assertion (A):** If the total surface area of a solid hemisphere is  $462 \text{ cm}^2$ , then its radius is 7cm

**Reason (R):** The total surface area of a hemisphere of radius  $r$  is  $4 \pi r^2$ .

Ans: (c)

9. **Assertion (A):** If the volumes of two spheres are in the ratio 64:27, then their surface areas are in the ratio, 4 : 3.

**Reason (R):** If the surface areas of two spheres are in the ratio 16 :9 then their volumes are in the ratio 64:27.

Ans: (d)

Ratio of surface areas of two spheres ( of radii  $r, R$ ) is  $r^2 : R^2$  where as ratio of volumes is  $r^3 : R^3$ .

10. **Assertion (A):** A cone is fixed on a cylinder of the same base radius. The surface area of the combination is CSA of the cone + CSA of the cylinder.

**Reason (R):** A cone is fixed on a cylinder of the same base radius. The volume of the combination is volume of the cone + volume of the cylinder

Ans: (d)

[In the Assertion Base area is to be added to the sum of CSAs]

### VERY SHORT ANSWER TYPE QUESTIONS (2 MARKS QUESTIONS)

1. The radius and height of a cylinder are in the ratio 2:3. If the volume is  $1386 \text{ cm}^3$ , find the radius and height.

Ans. Let the radius be  $2x$  and the height be  $3x$ .

Volume of cylinder =  $\pi r^2 h = \pi(2x)^2(3x) = 12\pi x^3$

$1386 = 12\pi x^3 \Rightarrow x^3 = 1386 / (12 \times \pi) \approx 36.78 \Rightarrow x \approx 3.33$

Radius =  $2x \approx 6.66 \text{ cm}$ , Height =  $3x \approx 9.99 \text{ cm}$

2. A cylindrical pipe has an inner diameter of 7 cm and length 40 cm. Find its inner curved surface area.

Ans. Radius = 3.5 cm, Height = 40 cm

CSA =  $2\pi r h = 2 \times \frac{22}{7} \times 3.5 \times 40 = 880 \text{ cm}^2$

3. Two solid hemispheres of radius 3.5 cm are joined to make a structure as shown Find the surface area of the structure.

Ans. Here the Surface area of the structure =  $2(\text{TSA of hemisphere}) = 2 \times 3 \pi r^2$ .

$$= 2 \times 3 \times \frac{22}{7} \times 3.5 \times 3.5 = 66 \times 3.5 = 231 \text{ cm}^2.$$



4. Find the capacity (in litres) of a cylindrical tank of radius 70 cm and height 1.2 m.

Ans. Height to cm: 1.2 m = 120 cm.

Volume =  $\pi r^2 h = \frac{22}{7} \times 70 \times 70 \times 120 = 1,848,000 \text{ cm}^3 = 184.8 \text{ litres}$

5. A toy is in the shape of a cone mounted on a hemisphere. If the radius is 3.5 cm and height of the cone is 4 cm, find the total surface area of the toy.

Ans. Slant height of cone =  $\sqrt{r^2 + h^2} = \sqrt{(3.5)^2 + 4^2} = 5.3 \text{ cm}$

Total Surface Area =  $\pi r(1 + r) = \frac{22}{7} \times 3.5 \times (5.3 + 3.5) = 96.8 \text{ cm}^2$ .

6. A capsule is made by joining two hemispheres to the ends of a cylinder. Radius is 2 cm and cylinder length is 6 cm. Find the surface area of the capsule.

Ans. Surface Area =  $2\pi rh$  (cylinder) +  $4\pi r^2$  (hemispheres) =  $2\pi r(h + 2r)$   
 $= 2 \times \frac{22}{7} \times 2 \times (6 + 2 \times 2) = \frac{880}{7} \text{ cm}^2$ .

7. A container is made up of a hemisphere and a cylinder. If the radius is 7 cm and the height of the cylinder is 13 cm, find the surface area of the container.

Ans. Surface Area =  $2\pi rh + 3\pi r^2 = 2\pi \times 7 \times 13 + 3\pi \times 49 = 182\pi + 147\pi = 329\pi \approx 1033.1 \text{ cm}^2$ .

8. A water tank is in the shape of a cylinder with a hemisphere on top. Radius is 1.5 m, height of cylindrical part is 2 m. Find the total surface area.

Ans. Surface Area =  $2\pi rh + 2\pi r^2 = 2\pi \times 1.5 \times 2 + 2\pi \times 2.25 = 6\pi + 4.5\pi = 10.5\pi \approx 32.99 \text{ m}^2$

9. A solid is formed by attaching a hemisphere to one end of a solid cylinder of radius 5 cm and height 10cm. Find the volume of the solid.

Ans. Volume = Volume of cylinder + Volume of hemisphere  
 $= \pi r^2 h + \frac{2}{3}\pi r^3 = \pi r^2 \times (h + \frac{2}{3}r) = \frac{22}{7} \times 5 \times 5 \times (10 + \frac{2}{3} \times 5) = \frac{22}{7} \times 25 \times \frac{40}{3} = \frac{22000}{7} \text{ cm}^3$ .

10. A solid is made of a cone sitting on a hemisphere. The common radius is 7 cm, and the height of the cone is 7 cm. Find the total volume of the solid.

Ans. Volume = Volume of cone + Volume of hemisphere  
 $= \frac{1}{3}\pi r^2 h + \frac{2}{3}\pi r^3 = \frac{1}{3}\pi r^2 (h + 2r) = \frac{1}{3} \times \frac{22}{7} \times 7 \times 7 \times (7 + 2 \times 7) = 22 \times 49 = 1078 \text{ cm}^3$

### **SHORT ANSWER TYPE QUESTIONS (3 MARKS QUESTIONS)**

1. A cylindrical water tank is 1.5 m in diameter and 2.1 m high. How many litres of water can it hold?

Ans. Volume of tank =  $\pi r^2 h = \frac{22}{7} \times \frac{1.5}{2} \times \frac{1.5}{2} \times 2.1 = \frac{11 \times 2.25 \times 0.3}{2} = 3.7125 \text{ m}^3$

$1 \text{ m}^3 = 1000 \text{ litres}$ . The capacity of the tank =  $3.7125 \times 1000 = 3712.5 \text{ litres}$ .

2. A cylinder and a cone have equal radii and equal heights. If their common radius is 3.5 cm and height is 10 cm, find the difference in their volumes.

Ans. Volume of cylinder =  $\pi r^2 h = \frac{22}{7} \times 3.5 \times 3.5 \times 10 = \frac{2695}{7} = 385 \text{ cm}^3$ .

Volume of cone =  $\frac{1}{3}\pi r^2 h = \frac{1}{3} \times \frac{22}{7} \times 3.5 \times 3.5 \times 10 = \frac{2695}{21} = 128.33 \text{ cm}^3$ .

Difference between the volumes =  $385 - 128.33 = 256.67 \text{ cm}^3$ .

3. A cylindrical pillar is 50 cm in diameter and 3.5 m in height. Find the cost of painting its curved surface at ₹12 per  $\text{m}^2$ .

Ans. Radius of the pillar =  $\frac{50}{2} = 25 \text{ cm} = 0.25 \text{ m}$

Surface area of the pillar =  $2\pi rh = 2 \times \frac{22}{7} \times 0.25 \times 3.5 = 5.50 \text{ m}^2$

Since, the Rate of painting is ₹12 per  $\text{m}^2$ , the cost =  $5.50 \times 12 = ₹66$ .

4. A hemispherical bowl of radius 10.5 cm is filled with soup. The soup is to be poured into cylindrical glasses of 200 ml capacity. How many glasses can be filled completely?

Ans. Volume of soup in the bowl =  $\frac{2}{3}\pi r^3 = \frac{2}{3} \times \frac{22}{7} \times 10.5 \times 10.5 \times 10.5 = 2425.5 \text{ cm}^3 = 2425.5 \text{ ml}$

Soup to be poured into a glass = 200 ml.

No. of glasses that can be filled =  $2425.5 \text{ ml} \div 200 = 12$  (approximately)

5. A toy is in the shape of a cone mounted on a hemisphere. The height of the entire toy is 14 cm and the diameter of the base is 6 cm. Find the total surface area of the toy.

Ans. Diameter of the toy = 6cm  $\Rightarrow$  radius = 3 cm.

Height of the entire toy = 14 cm. So, height of the conical part =  $14 - 3 = 11 \text{ cm}$ .

Slant height of the conical part =  $\sqrt{r^2 + h^2} = \sqrt{3^2 + 11^2} = \sqrt{130} \text{ cm}$ .

Surface area of the toy = CSA of hemispherical part + CSA of conical part

$$= 2\pi r^2 + \pi r l = \pi r(2r + l) = \frac{22}{7} \times 3 \times (2 \times 3 + \sqrt{130}) = \frac{66}{7}(6 + \sqrt{130}) \text{ cm}^2$$

6. The diameter of a roller is 84 cm and its length is 120 cm. It takes 500 complete revolutions to level a playground. Find the area of the playground.

Ans. Diameter = 84 cm  $\Rightarrow$  radius = 42 cm, length = 120 cm

Area levelled = CSA =  $2\pi r h = 2 \times \frac{22}{7} \times 42 \times 120 = 31,680 \text{ cm}^2$  per revolution

Total area of the play ground =  $500 \times 31,680 = 1,58,40,000 \text{ cm}^2 = 1584 \text{ m}^2$

7. A cylindrical container of radius 6 cm and height 15 cm is filled with ice cream. The ice cream is to be filled into cones of radius 3 cm and height 4 cm, each with a hemispherical top. How many such cones can be filled?

Ans. Cylinder: radius = 6 cm, height = 15 cm

Volume =  $\pi r^2 h = \frac{22}{7} \times 6^2 \times 15 = 3960 \text{ cm}^3$

Cone: radius = 3 cm, height = 4 cm

Volume =  $\frac{1}{3}\pi r^2 h = \frac{1}{3} \times \frac{22}{7} \times 9 \times 4 = \frac{264}{7} \text{ cm}^3$

Hemispherical top =  $\frac{2}{3}\pi r^3 = \frac{2}{3} \times \frac{22}{7} \times 27 = \frac{1188}{7} \text{ cm}^3$

Volume of ice cream filled in one cone =  $\frac{264}{7} + \frac{1188}{7} = \frac{1452}{7} \text{ cm}^3$

Number of cones = Volume of cylinder  $\div$  Volume of ice cream in one cone  
 $= 3960 \text{ cm}^3 \div \frac{1452}{7} \text{ cm}^3 = 19$  cones.

8. The surface area of a sphere is  $616 \text{ cm}^2$ . Find its radius and volume.

Ans. Surface area =  $616 \text{ cm}^2 = 4\pi r^2$

$$\Rightarrow r^2 = \frac{616 \times 7}{88} = 49 \Rightarrow r = 7 \text{ cm}$$

Volume =  $\frac{4}{3}\pi r^3 = \frac{4}{3} \times \frac{22}{7} \times 343 = 1372 \text{ cm}^3$

9. A tent is in the shape of a right circular cylinder up to a height of 3 m and a cone above it. The total height of the tent is 13.5 m and the radius is 14 m. Find the total surface area of the tent.

Ans. Height of cylinder = 3 m, cone height =  $13.5 - 3 = 10.5$  m, radius = 14 m

Slant height (l) =  $\sqrt{14^2 + 10.5^2} = \sqrt{306.25}$

CSA of cylinder =  $2\pi r h = 2 \times \frac{22}{7} \times 14 \times 3 = 264 \text{ m}^2$

CSA of cone =  $\pi r l = \frac{22}{7} \times 14 \times \sqrt{306.25} = \frac{308\sqrt{306.25}}{7}$

Total Surface area of the tent =  $264 + \frac{308\sqrt{306.25}}{7} \text{ m}^2$

10. A juice seller serves juice in a cylindrical glass of height 15 cm and diameter 7 cm. He also places a hemispherical lid over the glass. Find the total surface area of the glass with the lid .

Ans: Height of cylinder = 15 cm, diameter = 7 cm  $\Rightarrow$  radius = 3.5 cm.

Surface area of the glass with lid = CSA of Cyl. Part + CSA of HS part + base area

$$= 2\pi r h + 2\pi r^2 + \pi r^2 = \pi r (2h + 3r)$$

$$= \frac{22}{7} \times 3.5 (2 \times 15 + 3 \times 3.5) = 11 \times 41.5 = 456.5 \text{ cm}^2.$$

### LONG ANSWER TYPE QUESTIONS ( 5 MARKS QUESTIONS)

1. A container is in the shape of a cylinder with a hemispherical top. The height of the container is 10.5 m and the radius of the base is 3.5 m. Find the total surface area of the container and cost of painting it at the rate of Rs. 55 per sq.m. (Take  $\pi = \frac{22}{7}$ )

Ans. Height of container = 10.5 m, and radius = 3.5 m.

TSA of the container = CSA of Cyl. Part + CSA of HS part + base area

$$= 2\pi rh + 2\pi r^2 + \pi r^2 = \pi r \times (2h + 3r)$$

$$= \frac{22}{7} \times 3.5 (2 \times 10.5 + 3 \times 3.5) = 11 \times 31.5 = 346.5 \text{ m}^2.$$

Rate of painting = Rs. 55 per sq.m.

So, the cost of painting =  $346.5 \times 55 = \text{Rs. } 19057.5$ .

2. A Cylindrical vessel with internal diameter 28 cm contains water up to a height of 40 cm. A solid metallic spherical ball is completely immersed in the water and the level of water rises by 4 cm. Find:

(a) The volume of water displaced (b) The radius of the sphere. (Take  $\pi = \frac{22}{7}$ )

Ans. Diameter of vessel = 28 cm  $\Rightarrow$  Radius R = 14 cm, Height = water level raised = 4 cm.

(a) Volume of water displaced = Volume of cylinder =  $\pi R^2 h = \frac{22}{7} \times 14^2 \times 4 = 2464 \text{ cm}^3$ .

(b) Volume of sphere = Volume of water displaced =  $\frac{4}{3} \pi r^3 = 2464 \Rightarrow r^3 = 588 \Rightarrow r \approx 8.4 \text{ cm}$

Radius of the sphere = 8.4 cm.

3. A vessel full of water is in the form of an inverted cone of height 8 cm and the radius of its top, which is open, is 5 cm. 100 spherical lead balls are dropped into vessel. One-fourth of the water flows out of the vessel. Find the radius of a spherical ball.

Ans. Height of cone h = 8 cm radius of cone r = 5 cm

Number of spherical balls = 100

$$\text{Volume of water in cone} = \frac{1}{3} \pi r^2 h = \frac{1}{3} \times \pi \times 5^2 \times 8 = \frac{200}{3} \pi \text{ cm}^3$$

$$\text{Volume of water flown out} = \frac{1}{4} \times \frac{200}{3} \pi \text{ cm}^3 = \frac{50}{3} \pi \text{ cm}^3$$

Let the radius of one spherical ball be r cm

$$\text{Volume of sphere} = \frac{4}{3} \times \pi \times r^3$$

$$\therefore \text{volume of 100 spherical balls} = \frac{4}{3} \times \pi \times r^3 \times 100 \text{ cm}^3$$

$$\therefore \frac{4}{3} \times \pi \times r^3 \times 100 = \frac{50}{3} \pi; \quad r^3 = \frac{50}{4 \times 100} = \frac{1}{8}; \quad r = \frac{1}{2} = 0.5 \text{ cm}$$

4. A solid iron pole consists of a cylinder of height 220 cm and base diameter 24 cm, which is surmounted by another cylinder of height 60 cm and radius 8 cm. Find the mass of the pole, given that  $1 \text{ cm}^3$  of iron has approximately 8 gm mass. (Use  $\pi = 3.14$ )

Ans: Now, for small cylinder, Radius, r = 8 cm, Height, h<sub>1</sub> = 60 cm

$$\begin{aligned} \text{Volume of small cylinder} &= \pi r^2 h = 3.14 \times (8)^2 \times 60 \\ &= 3.14 \times 64 \times 60 = 12057.6 \text{ cm}^3 \end{aligned}$$

Volume of large cylinder, Height = h<sub>2</sub> = 220 cm

$$\text{Radius} = R_2 = \frac{\text{diameter}}{2} = \frac{24}{2} = 12 \text{ cm}$$

$$\begin{aligned} \text{Volume of large cylinder} &= \pi R_2^2 h_2 = 3.14 \times (12)^2 \times 220 \\ &= 3.14 \times 144 \times 220 = 99475.2 \text{ cm}^3 \end{aligned}$$

Now, Volume of pole = Volume of small cylinder + Volume of large cylinder =  $12057.6 + 99475.2 = 111532.8 \text{ cm}^3$

Since,  $1 \text{ cm}^3$  of iron has 8 gm mass

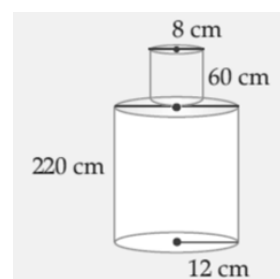

So, given volume of iron has mass =  $111532.8 \times 8 \text{ gm} = 892262.4 \text{ gm} = 892.2624 \text{ kg} = 892.262 \text{ kg}$   
 5. A rocket is in the form a right Circular Cylinder closed at the lower end and surmounted by a cone with same radius as that of cylinder. The diameter and height of the cylinder are 9 m and 15 m, respectively. If the slant height of the conical portion is the 7.5 m, find the total surface area and volume of the rocket.

Ans. Cylinder

diameter = 9 m  $\Rightarrow$  Radius  $r = 4.5 \text{ m}$ .

Cone

Radius  $r = 4.5 \text{ m}$  Slant height  $l = 7.5 \text{ m}$

height of cone  $h = \sqrt{l^2 - r^2}$ ,  $l = 6 \text{ m}$

TSA of Rocket =  $\pi r l + 2\pi r h + \pi r^2 = 594 \text{ m}^2$

Volume =  $\frac{1}{3} \pi r^2 h + \pi r^2 h = 1081.93 \text{ m}^3$

### CASE STUDY BASED QUESTIONS( 4 MARKS QUESTIONS)

1. The word 'circus' has the same root as 'circle'.

In a closed circular area, various entertainment acts including human skill and animal training are presented before the crowd.

A circus tent is cylindrical up to a height of 8 m and conical above it.

The diameter of the base is 28 m and the total height of the tent is 18.5 m.



Based on the above, answer the following questions:

- (i) Find the slant height of the conical part.
- (ii) Determine the floor area of the tent.
- (iii)(a) Find the area of the cloth used for making the tent.

**(OR)**

(b) Find the total volume of air inside an empty tent.

Ans. (i) Slant height of conical part:  $l = \sqrt{r^2 + h^2} = \sqrt{14^2 + 10.5^2} = \sqrt{306.25} = 17.5 \text{ m}$ .

(ii) Floor area =  $\pi r^2 = \frac{22}{7} \times 14 \times 14 = 44 \times 14 = 616 \text{ m}^2$ .

(iii) (a) Area of cloth used for making the tent:

Lateral surface area of cylinder =  $2\pi r h = 2\pi(14)(8) = 224\pi \text{ m}^2$

Curved surface area of cone =  $\pi r l = \pi(14)(17.5) = 245\pi \text{ m}^2$

Total cloth area =  $224\pi + 245\pi = 469\pi = 469 \times \frac{22}{7} = 67 \times 22 = 1474 \text{ m}^2$ .

(b) Total volume of air inside an empty tent = volume of the tent

Volume of cylinder =  $\pi r^2 h = \pi(14)^2(8) = 1568\pi \text{ m}^3$

Volume of cone =  $\frac{1}{3}\pi r^2 h = \frac{1}{3}\pi(14)^2(10.5) = 686\pi \text{ m}^3$

Total volume of tent =  $2254\pi = 2254 \times \frac{22}{7} = 322 \times 22 = 7084 \text{ m}^3$

2. Tamper-proof tetra-packed milk guarantees both freshness and security. This milk ensures uncompromised quality, preserving the nutritional values within and making it a reliable choice for health-conscious individuals. 500 mL milk is packed in a cuboidal container of dimensions 15 cm x 8 cm x 5 cm. These milk packets are then packed in cuboidal cartons of dimensions 30 cm x 32 cm x 15 cm.

Based on the above given information, answer the following questions :

(i) Find the volume of the cuboidal carton.

(ii)(a) Find the total surface area of a milk packet.

(OR)

(b) How many milk packets can be filled in a carton ?

(iii) How much milk can the cup (as shown in the figure) hold ?

Ans.(i) Volume of the carton =  $l \times b \times h = 30 \times 32 \times 15 = 14,400 \text{ cm}^3$

(ii) (a) Total Surface Area of a milk packet =  $2(lb + bh + hl)$

$$= 2(15 \times 8 + 8 \times 5 + 5 \times 15) = 2(235) = 470 \text{ cm}^2$$

(OR)

(ii)(b) Volume of one milk packet =  $15 \times 8 \times 5 = 600 \text{ cm}^3$

Number of milk packets in one carton = vol of carton  $\div$  vol of packet

$$= 14,400 \div 600 = 24$$

3. Metallic silos are used by farmers for storing grains. Manas has decided to build a new metallic silo to store his harvested grains. It is in the shape of a cylinder mounted by a cone. Dimensions of the conical part of a silo is as follows:

Radius of base = 1.5 m Height = 2 m

Dimensions of the cylindrical part of a silo is as follows:

Radius = 1.5 m Height = 7 m



On the basis of the above information answer the following questions.

(i) Calculate the slant height of the conical part of one silo.

(ii) Find the curved surface area of the conical part of one silo.

(iii)(a) Find the cost of metal sheet used to make the curved cylindrical part of 1 silo at the rate of ₹2000 per  $m^2$ .

(OR)

(b) Find the total capacity of one silo to store grains.

$$\text{Ans. (i) } l = \sqrt{r^2 + h^2} = \sqrt{1.5^2 + 2^2} = \sqrt{2.25 + 4} = \sqrt{6.25} = 2.5 \text{ m}$$

$$\text{(ii) CSA of cone} = \pi r l = \frac{22}{7} \times 1.5 \times 2.5 = 11.78 \text{ m}^2$$

$$\text{(iii) (a) CSA of cylinder} = 2\pi r h = 2 \times \frac{22}{7} \times 1.5 \times 7 = 66 \text{ m}^2$$

$$\text{Cost of metal sheet used} = 66 \times 2000 = ₹1,32,000$$

(OR)

$$(iii)(b) \text{ Volume of cylinder} = \pi r^2 h = \frac{22}{7} \times (1.5)^2 \times 7 = 49.5 \text{ m}^3$$

$$\text{Volume of cone} = \frac{1}{3} \pi r^2 h = \frac{1}{3} \times \frac{22}{7} \times (1.5)^2 \times 2 = 4.71 \text{ m}^3$$

$$\text{Total capacity} = 49.5 + 4.71 = 54.21 \text{ m}^3$$

### **HIGHER ORDER THINKING SKILLS QUESTIONS:**

1. A solid toy is in the form of a hemisphere surmounted by a right circular cone. The height of the cone is 4 cm and diameter of the base is 8 cm. Determine the volume of the toy. If the cube circumscribes the toy, then find the difference of the volumes of the cube and the toy. Also, find the total surface area of the toy.

Ans: (i) Volume of toy = Volume of cone + Volume of hemisphere

$$= \frac{1}{3} \pi r^2 h + \frac{2}{3} \pi r^3 = \frac{1}{3} \pi r^2 (h + 2r) = \frac{1}{3} \times \frac{22}{7} \times 4 \times 4 \times (4 + 2 \times 4) = \frac{4221}{21} \text{ cm}^3$$

$$(ii) \text{ Side of cube} = 8 \text{ cm} \Rightarrow \text{Volume} = 8^3 = 512 \text{ cm}^3$$

$$\text{Difference} = 512 - \frac{4221}{21} = 512 - 201.06 = 310.94 \text{ cm}^3$$

(iii) Includes curved surface area (CSA) of cone and hemisphere.

$$\text{Slant height (l) of cone} = 4\sqrt{2}$$

$$\text{CSA of cone} = \pi r l = 16\pi\sqrt{2} \quad \text{CSA of hemisphere} = 2\pi r^2 = 32\pi$$

$$\text{Total Surface Area} = 71.02 + 100.53 = 171.55 \text{ cm}^2$$

2. The circumference of the base of a cylindrical vessel is 132 cm and its height is 25 cm. How many litres of water can it hold?

Ans. Volume of Cylindrical Vessel

$$\text{Given: Circumference} = 132 \text{ cm} \Rightarrow 2\pi r = 132 \Rightarrow r = 21 \text{ cm} \quad \text{so, Height} = 25 \text{ cm}$$

$$\text{Volume} = \pi r^2 h = 3.1416 \times 21^2 \times 25 = 34636.5 \text{ cm}^3$$

$$\text{Converting into litres: } 34636.5 \div 1000 = 34.64 \text{ litres}$$

3. An iron pillar has some part in the form of a right circular cylinder and remaining in the form of a right circular cone. The radius of base of each of cone and cylinder is 8 cm. The cylindrical part is 240 cm high and the conical part is 36 cm high. Find

(i) The volume of iron used

(ii) The weight of pillar, if 1 cm<sup>3</sup> of iron weighs 10g.

Ans. Iron Pillar (Cylinder + Cone) = (i) Volume of Iron Used:

$$\text{Cylinder: } \pi r^2 h = \pi \times 64 \times 240 = 15360\pi \quad \text{Cone: } \frac{1}{3} \pi r^2 h = \frac{1}{3} \pi \times 64 \times 36 = 768\pi$$

$$\text{Total Volume} = 16128\pi = 50669.8 \text{ cm}^3$$

$$(ii) \text{ Weight of Pillar: Density} = 10 \text{ g/cm}^3 \Rightarrow \text{Weight} = 50669.8 \times 10 = 506698 \text{ g} = 506.70 \text{ kg}$$

## CHAPTER 13 STATISTICS MIND MAP

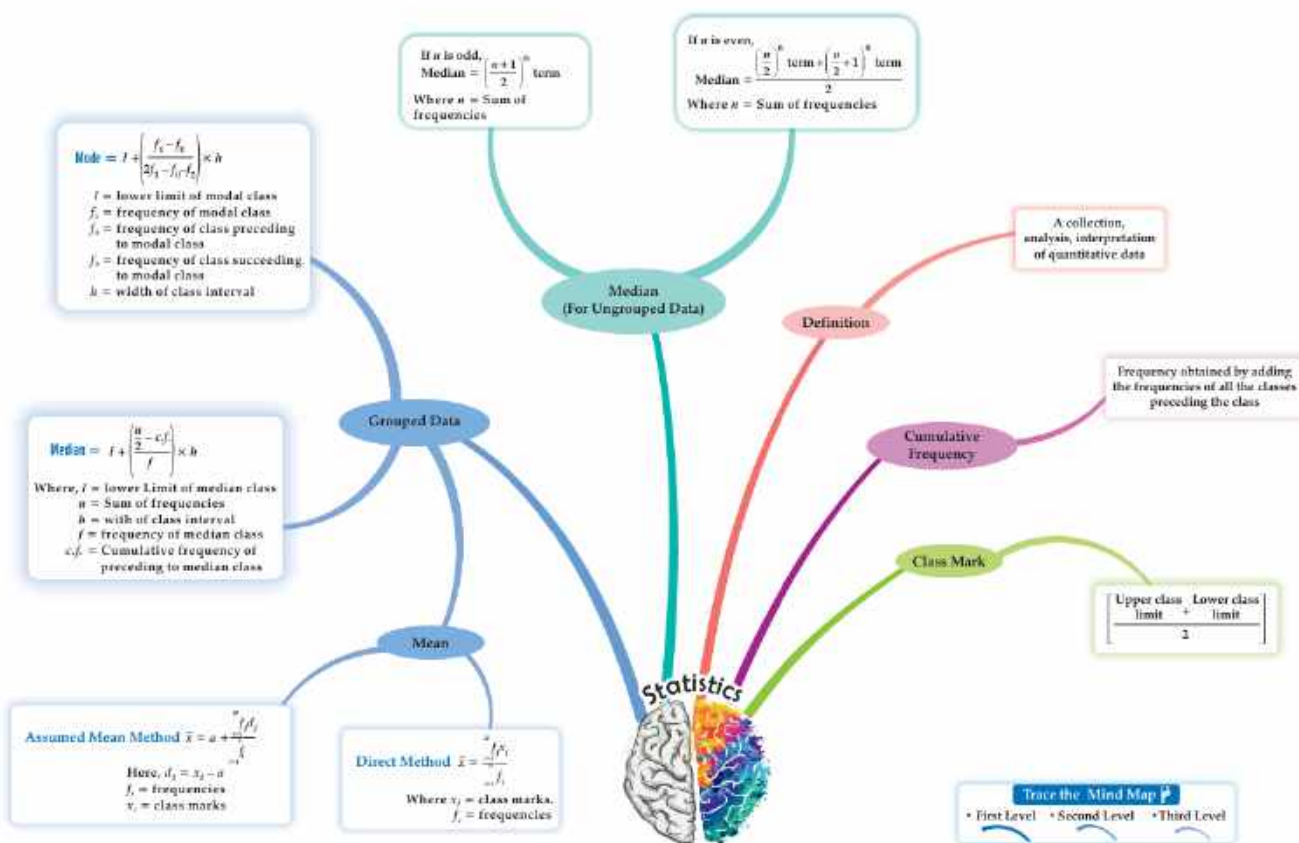

### GIST OF THE CHAPTER

\* In the chapter of statistics, we will study about the techniques for finding the mean, median and mode of grouped data.

\* There are three measures of central tendency which are i) mean ii) mode iii) median

**Mean** (the average of given set of data)

To calculate the mean of grouped data, there are three methods

- (1) Direct method      (2) Assumed mean method (shortcut method)      (3) Step deviation method

#### **i) Direct method**

- a. Make a frequency table in which the first column consists of the class intervals, the second consists of the corresponding frequencies ( $f_i$ ), the third consists of the class marks (mid point of the class intervals) denoted by  $x_i$  and the fourth column is  $f_i x_i$

1. Formula for mean in direct method  $\bar{x} = \frac{\sum f_i x_i}{\sum f_i}$

#### **ii) Assumed mean method (short-cut method)**

1. Formula Mean ( $\bar{x}$ ) =  $a + \frac{\sum f_i d_i}{\sum f_i}$
2.  $d_i = x_i - a$  where 'a' is assumed mean (one of the mid values)
3.  $d_i$  may be -ve (or) +ve (or) zero

#### **iii) Step deviation method**

1. Formula Mean ( $\bar{x}$ ) =  $a + \left(\frac{\sum f_i u_i}{\sum f_i}\right) Xh$

Here  $u_i = \frac{x_i - a}{h}$ , where 'a' is assumed mean,  
h is the class size (upper limit-lower limit)

### Mode

In a grouped frequency distribution, it is not possible to determine the mode by looking at the frequencies.

To compute the mode, at first, we locate a class with the maximum frequency, called the modal class

Formula:  $\text{Mode} = l + \left( \frac{f_1 - f_0}{2f_1 - f_0 - f_2} \right) X h$  Where  $l$  = lower limit of the modal class

$f_1$  = frequency of modal class (the highest frequency)

$f_0$  = frequency of the class preceding the modal class

$f_2$  = frequency of the class succeeding the modal class

### Median

To compute median, at first we locate a class whose cumulative frequency is greater than or nearest to  $\frac{n}{2}$ , called the median class.

Formula:  $\text{Median} = l + \left( \frac{\frac{n}{2} - cf}{f} \right) X h$

Where  $l$  = lower limit of the modal class

$n$  = sum of frequency =  $\sum f_i$

$f$  = frequency of the median class

$h$  = size of the median class (class size to be equal)

$cf$  = cumulative frequency of the class preceding the

median class

### Empirical formula

The relation among Mean, Mode and Median:  $\text{Mode} = 3 \text{ Median} - 2 \text{ Mean}$

#### **MULTIPLE CHOICE QUESTIONS (1 MARK QUESTIONS)**

1) If the difference of the mode and median of a data is 24, then the difference of its median and mean is

(a) 8

(b) 12

(c) 24

(d) 36

Ans: (b)

Solution:  $\text{Mode} - \text{median} = 24$  (given)

$\text{Mode} = 3 \text{ median} - 2 \text{ mean}$

$\text{Mode} - \text{median} = 2(\text{median} - \text{mean})$

$\Rightarrow \text{Median} - \text{mean} = \frac{24}{2} = 12$

2) If the value of each observation in the data is increased by 2, then median of the new data is

(a) Increased by 2

(b) Increased by  $2n$

(c) Remains same

(d) Decreases by 2

Ans: (a)

Solution: As we know, if the value of each observation in the data is increased, then the median will also increase. Here, each observation in the data is increased by 2. Hence the new median will also increase by 2

3) The following distribution gives the daily income of 50 workers of the factory. The lower limit of the modal class is

Income (in ₹)	400-424	425-449	450-474	475-499	500-524
Number of workers	12	14	8	6	10

(a) 25

(b) 449

(c) 424.5

(d) 425.5

Ans: (c)

Solution: C.I against highest frequency (14) is 425-449 (Modal class), but the class is not continuous.

$\therefore$  424.5-449.5. The lower limit is 424.5

4) The class marks of the median class of the following data is

Class intervals	10-25	25-40	40-55	55-70	70-85	85-100
frequency	2	3	7	6	6	6

- (a) 40                      (b) 55                      (c) 47.5                      (d) 62.5

Ans: (d)

Solution:  $n=30 \Rightarrow \frac{n}{2}=15$ . Cumulative frequencies are 2,5,12,18,24,30

$\frac{n}{2}$  lies within 18  $\rightarrow$  against to 55-70 ;(Median class). So, Class marks is  $\frac{51+70}{2} = \frac{125}{2} = 62.5$

5) For the following distribution:

Marks	Below 10	Below 20	Below 30	Below 40	Below 50	Below 60
Number of students	3	12	27	57	75	80

The modal class is:

- (a) 10-20                      (b) 20-30                      (c) 30-40                      (d) 50-60

Ans: (c)

Solution:

Class intervals (C.I)	0-10	10- 20	20- 30	30-40	40- 50	50-60
frequency	3	9	15	30	18	5

Now C.I against highest frequency (30) is 30-40  $\therefore$  Modal class is 30-40

6) Consider the data:

Class intervals	65-85	85-105	105-125	125-145	145-165	165-185	185-205
frequency	4	5	13	20	14	7	4

The difference of the upper limit of the median class and the lower limit of the modal class:

- (a) 0                      (b) 19                      (c) 38                      (d) 20

Ans: (d)

Solution:

Class intervals	65-85	85-105	105-125	125-145	145-165	165-185	185-205
Cumulative frequency	4	9	22	42	56	63	67

$n/2 = 67/2 \Rightarrow 33.5$  lies in 125-145 (Median class), Modal class is 125-145 (as of its high frequency)

20) Upper limit of Median class-Lower limit of modal class = 145- 125 =20

7) After an examination, a teacher wants to know the average marks of the students in the class. She requires the calculation \_\_\_\_\_ of marks.

- (a) Median                      (b) mean                      (c) mode                      (d) range

Ans: (b)

Solution: Average related to mean.

8) The mode and mean of the data are  $15x$  and  $18x$ , respectively. Then the median of the data is

- (a)  $x$                       (b)  $11x$                       (c)  $17x$                       (d)  $34x$

Ans: (c)

Solution: mode=3median-2 mean

$$15x=3 \text{ median}-2 (18x)$$

$$15x+36x=3 \text{ median} \Rightarrow 51x=3 \text{ median}$$

$$\text{Median} = \frac{51x}{3} = 17x$$

9) The mode of the following data is

$x_i$	10	14	18	21	25
$f_i$	10	15	7	9	9

- (a)16                      (b) 10                      (c) 12                      (d)14

Ans: (d)

Solution: The mode is the most frequent observation. Here, the mode is 14 with a frequency of 5  
10)The mean of the following distribution is

$x_i$	12	14	18	20
$f_i$	3	5	8	7

- (a)19.5                      (b)18                      (c)16.95                      (d)15.24

Ans: (c)

Solution:  $\sum fix_i = 3 \times 12 + 5 \times 14 + 8 \times 18 + 7 \times 20 = 36 + 70 + 144 + 140 = 390$

$$\text{Mean} = \frac{\sum fix_i}{\sum f_i} = \frac{390}{23} = 16.95$$

### ASSERTION AND REASONING QUESTIONS

**DIRECTION:** In the following questions, a statement of **Assertion (A)** is followed by a statement of **Reason (R)**. Choose the correct option

- (a) Both assertion (A) and reason (R) are true and reason (R) is the correct explanation of assertion (A)  
 (b) Both assertion (A) and reason (R) are true and reason (R) is not the correct explanation of assertion (A)  
 (c) Assertion (A) is true but reason (R) is false.  
 (d) Assertion (A) is false but reason (R) is true.

1. **Assertion (A):** The arithmetic mean of the following given frequency distribution table is 13.81.

Marks	2.5 – 5.5	5.5 – 8.5	8.5 – 11.5	11.5 – 14.5	14.5 – 17.5	17.5 – 20.5
No. of Students	7	10	15	20	25	30

**Reason (R):** Mean =  $\sum fx / \sum f$

Ans: (a)

2. **Assertion (A):** If the value of mode and mean is 60 and 66 respectively, then the value of median is 64.

**Reason (R):** Median = (mode + 2 mean)/2

Ans: (c)

$$\text{Median} = \frac{1}{3}(\text{mode} + 2\text{mean}) = \frac{1}{3}[60 + 2(66)] = \frac{1}{3} \times 192 = 64$$

3. **Assertion(A):** If the value of mode and median is 50.5 and 45.5 respectively, then the value of 2 mean is 86.

**Reason (R):** Median = (Mode + 2 Mean)

Ans.(c)

$$\text{Mode} = 3\text{Median} - 2\text{Mean} \Rightarrow (50.5) = 3(45.5) - 2\text{Mean} \Rightarrow 2\text{Mean} = 136.5 - 50.5 = 86$$

4. **Assertion (A):** Consider the following frequency distribution:

Class Interval	10 – 15	15 – 20	20 – 25	25 – 30	30 – 35
Frequency	5	9	12	6	8

The modal class is 10 – 15.

**Reason (R):** The class having maximum frequency is called the modal class.

Ans. (d)

The maximum frequency is 12, which lies in the interval 20 – 25. So, the modal class is 20 – 25.

5. **Assertion (A):** For a moderately asymmetric distribution, Mode- Median = 2(Median-Mean)

**Reason (R):** For a symmetric distribution Mean = Median = Mode

Ans(b)

6. **Assertion (A):** The algebraic sum of the deviations of a frequency distribution from its mean is 0

**Reason (R):** Mode of a frequency distribution cannot be determined graphically.

Ans(c)

7. **Assertion (A):** The mean of 1, 4, 7, 10 .....301 is 151.

**Reason (R):** The mean of series a, a+d, a+2d.....a+2nd, is a+nd

Ans(b)

8. **Assertion (A) :** The mode of the following distribution is 52.

Class interval	0-20	20-40	40-60	60-80
Frequency	4	3	2	2

**Reason (R) :** The value of the observation which occurs most often is the mode.

Ans:(d)

9. **Assertion (A):** If for a data mean: median = 9:8 then Median : Mode = 4:3

**Reason (R):** Emperical formula mode = 3 median – 2 Mean

Ans(a)

10.**Assertion (A):** The arithmetic mean of 1002, 1004, 1006, 1008, 1003 and 1007 is 1005

Sum of all observations

**Reason (R):** arithmetic mean=  $\frac{\text{Total no. of observations}}{\text{Total no. of observations}}$

Ans:(a)

**VERY SHORT ANSWER TYPE QUESTIONS( 2 MARKS QUESTIONS)**

1. The mean and mode of a frequency distribution are 28 and 16 respectively. Find the median.

Ans:We know that, Mode = 3 Median – 2 Mean

$$\Rightarrow 3 \text{ Median} = \text{Mode} + 2 \text{ Mean} \Rightarrow 3 \text{ Median} = 16 + 2 \times 28 \Rightarrow \text{Median} = 72/3 = 24$$

2. The runs scored by a batsman in 35 different matches are given below:

Runs Scored	0-15	15-30	30-45	45-60	60-75	75-90
Frequency	5	7	4	8	8	3

Find the lower limit of the median class .

Ans:

Runs Scored	Frequency	cf
0-15	5	5
15-30	7	12
30-45	4	16
45-60	8	24
60-75	8	32
75-90	3	35

Here,  $n = 35 \Rightarrow n/2 = 17.5$  & Median class is 45 – 60. Hence, lower limit is 45.

3.For the following distribution: Find the modal class.

Marks	Below 10	Below 20	Below 30	Below 40	Below 50	Below 60
No. of Students	3	12	27	57	75	80

Ans:

Marks	0 – 10	10 – 20	20 – 30	30 – 40	40 – 50	50 – 60
No. of Students	3	9	15	30	18	5

Highest frequency is 30 which belong to 30 – 40. Hence, Modal class is 30 – 40.

4. For the following distribution, find the upper limit of the median class

Class	0-5	6-11	12-17	18-23	24-29
Frequency	13	10	15	8	11

Ans: Here,  $n = 57$  So,  $\frac{n}{2} = 28.5$

Class	Frequency	cf
- 0.5 - 5.5	13	13
5.5 - 11.5	10	23
11.5 - 17.5	15	38
17.5 - 23.5	8	46
23.5 - 29.5	11	57

The cumulative frequency, just greater than 28.5, is 38 which belongs to class 11.5 - 17.5. So, the median class is 11.5 - 17.5. Its upper limit is 17.5

5. If the mean of the following distribution is 2.6, then  $y = ?$

Variable (x)	1	2	3	4	5
Frequency	4	5	y	1	2

Ans:

Variable (x)	Frequency (f)	fx
1	4	4
2	5	10
3	y	3y
4	1	4
5	2	10
<b>Total</b>	$y + 12$	$3y + 28$

Here,  $\sum f = y + 12$  and  $\sum fx = 3y + 28$

$$\text{Mean, } \bar{x} = \frac{\sum fx}{\sum f} \Rightarrow 2.6 = \frac{3y + 28}{y + 12} \Rightarrow 3y + 28 = 2.6y + 31.2$$

$$\Rightarrow 0.4y = 3.2 \Rightarrow y = 8$$

6. In a continuous frequency distribution with usual notations, if  $l = 32.5$ ,  $f_1 = 15$ ,  $f_0 = 12$ ,  $f_2 = 8$  and  $h = 8$ , then find the mode .

Ans. 
$$\text{Mode} = l + \frac{f_1 - f_0}{2f_1 - f_0 - f_2} \times h$$

$$\Rightarrow \text{Mode} = 32.5 + \frac{15 - 12}{30 - 12 - 8} \times 8 = 32.5 + \frac{3}{10} \times 8 = 32.5 + 2.5 = 34.9$$

7. Consider the following frequency distribution of the heights (in cm) of 60 students of a class:

Class	150 - 155	155 - 160	160 - 165	165 - 170	170 - 175	175 - 180
Frequency	15	13	10	8	9	5

Find the upper limit of the median class.

Ans.

Class	Frequency	$cf$
150 – 155	15	15
155 – 160	13	28
160 – 165	10	38
165 – 170	8	46
170 – 175	9	55
175 – 180	5	60

Here,  $n = 60 \Rightarrow \frac{n}{2} = 30$ , Median class is 160 – 165, Hence, upper limit is 165.

8. If the value of each observation of a statistical data is increased by 3, then the what happens to mean of the data?

Ans. Mean increases by 3

If each value of observation is increased by 3, then mean is also increased by 3.

9. Consider the following frequency distribution of the heights (in cm) of 60 students of a class:

Class	150 – 155	155 – 160	160 – 165	165 – 170	170 – 175	175 – 180
Frequency	16	12	9	7	10	6

Find the sum of the lower limit of the modal class and the upper limit of the median class.

Ans:

Class	Frequency	$cf$
150 – 155	16	16
155 – 160	12	28
160 – 165	9	37
165 – 170	7	44
170 – 175	10	54
175 – 180	6	60

The class having the maximum frequency is the modal class.

So, the modal class is 150 – 155 and its lower limit is 150.

Also,  $n = 60 \Rightarrow n/2 = 30$ , Median class is 160 – 165 whose upper limit is 165

$\therefore$  Required sum =  $(150 + 165) = 315$

10. If the difference of Mode and Median of a data is 24, then find the difference of median and mean.

Ans: mode – median = 24 (given)

$\therefore$  mode = 24 + median

Since, mode = 3 median – 2 mean [By empirical relation]

$\therefore$  24 + median = 3 median – 2 mean

$\Rightarrow$  2 median – 2 mean = 24

$\Rightarrow$  median – mean = 12

### **SHORT ANSWER TYPE QUESTIONS (3 MARKS QUESTIONS)**

1. If mode of the following frequency distribution is 55 then find the value of x.

Class	0 – 15	15 – 30	30 – 45	45 – 60	60 – 75	75 – 90
Frequency	10	7	x	15	10	12

Ans: Since the mode is 55 which belongs to 45 – 60, therefore modal class is 45 – 60

Here,  $l = 45, f_0 = x, f_1 = 15, f_2 = 10, h = 15$

$$\text{Mode} = l + \frac{f_1 - f_0}{2f_1 - f_0 - f_2} \times h \Rightarrow 55 = 45 + \frac{15 - x}{30 - x - 10} \times 15$$

$$\Rightarrow 10 = \frac{15 - x}{20 - x} \times 15 \Rightarrow 2 = \frac{15 - x}{20 - x} \times 3 \Rightarrow 40 - 2x = 45 - 3x$$

$$\Rightarrow 30 - 2x = 45 - 40 \Rightarrow x = 5$$

2. The mode of a grouped frequency distribution is 75 and the modal class is 65-80. The frequency of the class preceding the modal class is 6 and the frequency of the class succeeding the modal class is 8. Find the frequency of the modal class.

Ans. Here,  $l = 65, f_0 = 6, f_1 = x, f_2 = 8, h = 15$

$$\text{Mode} = l + \frac{f_1 - f_0}{2f_1 - f_0 - f_2} \times h \Rightarrow 75 = 65 + \frac{x - 6}{2x - 6 - 8} \times 15$$

$$\Rightarrow 10 = \frac{x - 6}{2x - 14} \times 15 \Rightarrow 2 = \frac{x - 6}{2x - 14} \times 3 \Rightarrow 4x - 28 = 3x - 18$$

$$\Rightarrow 4x - 3x = 28 - 18 \Rightarrow x = 10$$

3. If the mean of the following frequency distribution is 62.8, then find the missing frequency  $x$  :

Class	0 - 20	20 - 40	40 - 60	60 - 80	80 - 100	100 - 120
Frequency	5	8	$x$	12	7	8

Ans.

Class	Frequency	$x$	$fx$
0 - 20	5	10	50
20 - 40	8	30	240
40 - 60	$x$	50	50 $x$
60 - 80	12	70	840
80 - 100	7	90	630
100 - 120	8	110	880
	$x + 40$		$50x + 2640$

Here,  $\sum f = x + 40$  and  $\sum fx = 50x + 2640$

$$\text{Mean, } \bar{x} = \frac{\sum fx}{\sum f} \Rightarrow 62.8 = \frac{50x + 2640}{x + 40} \Rightarrow 2512 + 62.8x = 50x + 2640$$

$$\Rightarrow 62.8x - 50x = 2640 - 2512 \Rightarrow 12.8x = 128 \Rightarrow x = 10 \therefore \text{Missing frequency, } x = 10$$

4. Calculate median marks of the following data:

Marks	0 - 10	10 - 20	20 - 30	30 - 40	40 - 50	Total
No. of Students	8	16	36	34	6	100

Ans:

Marks	No. of Students	cf
0 – 10	8	8
10 – 20	16	24
20 – 30	36	60
30 – 40	34	94
40 – 50	6	100
Total	100	

Here,  $n = 100 \Rightarrow n/2 = 50$

$\Rightarrow$  Median class is 20 – 30

$l = 20, cf = 24, f = 36, h = 10$

$$\text{Median} = l + \left( \frac{\frac{n}{2} - cf}{f} \right) \times h$$

$$\Rightarrow \text{Median} = 20 + \left( \frac{50 - 24}{36} \right) \times 10 = 20 + \frac{26 \times 10}{36} = 20 + \frac{65}{9} = 20 + 7.22 = 27.22$$

5. The arithmetic mean of the following frequency distribution is 53. Find the value of k.

Class	0 – 20	20 – 40	40 – 60	60 – 80	80 – 100
Frequency	12	15	32	k	13

Ans:

Class	Frequency	x	u	fu
0 – 20	12	10	-3	-36
20 – 40	15	30	-2	-30
40 – 60	32	50	-1	-32
60 – 80	k	70	0	0
80 – 100	13	90	1	13
Total	k + 72			-85

Here,  $\sum f = k + 72$  and  $\sum fu = -85, h = 20, a = 70$

$$\text{Mean, } \bar{x} = a + \left( \frac{\sum fu}{\sum f} \times h \right) \Rightarrow 53 = 70 + \left( \frac{-85}{k + 72} \times 20 \right) \Rightarrow -17 = \frac{-85 \times 20}{k + 72} \Rightarrow 1 = \frac{100}{k + 72}$$

$$\Rightarrow k + 72 = 100 \Rightarrow k = 100 - 72 = 28$$

6. The below table shows the ages of persons who visited a museum on a certain day. Find the median age of the person visiting the museum.

Age (in years)	Less than 10	Less than 20	Less than 30	Less than 40	Less than 50	Less than 60
No. of persons	3	10	22	40	54	71

Ans:

Age (in years)	No. of persons	cf
0 – 10	3	3
10 – 20	7	10
20 – 30	12	22
30 – 40	18	40
40 – 50	14	54
50 – 60	17	71

Here,  $n = 71 \Rightarrow n/2 = 35.5$

$\Rightarrow$  Median class is 30 – 40

$l = 30, cf = 22, f = 18, h = 10$

$$\text{Median} = l + \left( \frac{\frac{n}{2} - cf}{f} \right) \times h$$

$$\Rightarrow \text{Median} = 30 + \left( \frac{35.5 - 22}{18} \right) \times 10 = 30 + \frac{13.5 \times 10}{18} = 30 + \frac{135}{18} = 30 + 7.5 = 37.5$$

The median age of the person visiting the museum is 37.5 years.

7. Heights of 50 students in class X of a school are recorded and following data is obtained:

Height (in cm)	130 – 135	135 – 140	140 – 145	145 – 150	150 – 155	155 – 160
No. of students	4	11	12	7	10	6

Find the median height of the students.

Ans: 144.17



8. Calculate mode of the following data:

Marks	0 – 20	20 – 40	40 – 60	60 – 80	80 – 100
No. of Students	5	10	12	6	3

Ans: Since the maximum frequency is 12 which belongs to 40 – 60, therefore modal class is 40 – 60

Here,  $l = 40, f_0 = 10, f_1 = 12, f_2 = 6, h = 20$

$$\text{Mode} = l + \frac{f_1 - f_0}{2f_1 - f_0 - f_2} \times h \Rightarrow \text{Mode} = 40 + \frac{12 - 10}{24 - 10 - 6} \times 20 = 40 + \frac{2}{8} \times 20 = 40 + 5 = 45$$

9. Calculate median marks of the following data:

Marks	0 – 10	10 – 20	20 – 30	30 – 40	40 – 50
No. of Students	2	12	22	8	6

Ans: 25



10. Calculate mode of the following data:

Marks	0 – 6	6 – 12	12 – 18	18 – 24	24 – 30
No. of Students	7	5	10	12	6

Ans: 19.5



**LONG ANSWER TYPE QUESTIONS ( 5 MARKS QUESTIONS)**

1. The median of the following data is 868. Find the values of x and y, if the total frequency is 100

Class	800 – 820	820 – 840	840 – 860	860 – 880	880 – 900	900 – 920	920 – 940
Frequency	7	14	x	25	y	10	5

Ans:

Class	Frequency	C.f
800 – 820	7	7
820 – 840	14	21
840 – 860	x	x + 21
860 – 880	25	x + 46
880 – 900	y	x + y + 46
900 – 920	10	x + y + 56
920 – 940	5	x + y + 61

From table, we have  $x + y + 61 = 100 \Rightarrow x + y = 100 - 61 \Rightarrow x + y = 39$

Here, median = 868, therefore median class is 860 – 880

So,  $l = 860$ ,  $cf = x + 21$ ,  $f = 25$ ,  $h = 20$ ,  $n/2 = 50$

$$\text{Now, Median} = l + \left( \frac{\frac{n}{2} - cf}{f} \times h \right) \Rightarrow 868 = 860 + \left( \frac{50 - (x + 21)}{25} \times 20 \right)$$

$$\Rightarrow 868 - 860 = \left( \frac{50 - x - 21}{5} \times 4 \right) \Rightarrow 8 = \frac{29 - x}{5} \times 4$$

$$\Rightarrow 40 = (29 - x)4 \Rightarrow 29 - x = 10 \Rightarrow x = 29 - 10 = 19$$

$$\Rightarrow y = 39 - 19 = 20$$

2. The distribution below gives the makes of 100 students of a class, if the median makes are 24, find the frequencies  $f_1$  and  $f_2$

Marks	0-5	5-10	10-15	15-20	20-25	25-30	30-35	35-40
No. of students	4	6	10	$f_1$	25	$f_2$	18	5

Ans:

Class	Frequency	cf
0 – 5	4	4
5 – 10	6	10
10 – 15	10	20
15 – 20	$f_1$	$20 + f_1$
20 – 25	25	$45 + f_1$
25 – 30	$f_2$	$45 + f_1 + f_2$
30 – 35	18	$63 + f_1 + f_2$
35 – 40	5	$68 + f_1 + f_2$

Now,  
25

Median = 24 (Given) , So, median class = 20 –

$$l = 20, h = 5, n/2 = 50, cf = 20 + f_1, f = 25 \quad , \text{ We know, Median} = l + \left( \frac{\frac{n}{2} - cf}{f} \times h \right)$$

$$\Rightarrow 24 = 20 + \frac{50 - (20 + f_1)}{25} \times 5 \Rightarrow 4 = \frac{30 - f_1}{5} \Rightarrow 30 - f_1 = 20 \Rightarrow f_1 = 10 \quad ,$$

Also, sum of frequencies = 100

$$\Rightarrow 68 + f_1 + f_2 = 100 \Rightarrow f_1 + f_2 = 32 \quad \Rightarrow 10 + f_2 = 32 \quad \Rightarrow f_2 = 22$$

$$\therefore f_1 = 10, f_2 = 22.$$

3. The distribution below gives the marks of 40 students of a class, if the median marks are 32.5, find the frequencies  $f_1$  and  $f_2$

Marks	0-10	10-20	20-30	30-40	40-50	50-60	60-70	Total
No. of students	$f_1$	5	9	12	$f_2$	3	2	40

Ans.

Marks	No. of students	$cf$
0-10	$f_1$	$f_1$
10-20	5	$5 + f_1$
20-30	9	$14 + f_1$
30-40	12	$26 + f_1$
40-50	$f_2$	$26 + f_1 + f_2$
50-60	3	$29 + f_1 + f_2$
60-70	2	$31 + f_1 + f_2$
Total	40	

$$\text{Here, } n = 40 \Rightarrow 31 + f_1 + f_2 = 40 \Rightarrow f_1 + f_2 = 9 \dots (i)$$

Given, median = 32.5, which lies in the class interval 30-40. So, median class is 30-40.

$$\therefore l = 30, h = 10, f = 12, n = 40 \text{ and c.f. of preceding class, } cf = f_1 + 14$$

$$\text{Median} = l + \left( \frac{\frac{n}{2} - cf}{f} \right) \times h$$

$$\Rightarrow 32.5 = 30 + \left( \frac{20 - f_1 - 14}{12} \right) \times 10 \Rightarrow 2.5 = \left( \frac{6 - f_1}{12} \right) \times 10 \Rightarrow 30 = (6 - f_1) \times 10 \Rightarrow 3 = 6 - f_1 \Rightarrow f_1 = 3$$

$$\Rightarrow f_2 = 9 - 3 = 6$$

4. The mean of the following data is 42. Find the missing frequencies  $x$  and  $y$  if the sum of frequencies is 100.

Class	0-10	10-20	20-30	30-40	40-50	50-60	60-70	70-80
Frequency	7	10	$x$	13	$y$	10	14	9

Ans.

Class	Frequency	$x$	$u$	$fu$
0-10	7	5	-2	-14
10-20	10	15	-1	-10
20-30	$x$	25	0	0
30-40	13	35	1	13
40-50	$y$	45	2	$2y$
50-60	10	55	3	30
60-70	14	65	4	56
70-80	9	75	5	45
<b>Total</b>	100			$2y + 120$

Here,  $\sum f = 100 = x + y + 63 \Rightarrow x + y = 37$

and  $\sum fu = 2y + 120$ ,  $h = 10$ ,  $a = 25$

$$\text{Mean, } \bar{x} = a + \left( \frac{\sum fu}{\sum f} \times h \right) \Rightarrow 42 = 25 + \left( \frac{2y + 120}{100} \times 10 \right) \Rightarrow 17 = \frac{2y + 120}{10} \Rightarrow 170 = 2y + 120$$

$$\Rightarrow 2y = 170 - 120 = 50 \Rightarrow y = 25 \Rightarrow x = 37 - 25 = 12$$

5. The following data gives the distribution of total monthly household expenditure of 200 families of a village. Find the modal monthly expenditure of the families. Also, find the mean monthly expenditure.

Expenditure	1000-1500	1500-2000	2000-2500	2500-3000	3000-3500	3500-4000	4000-4500	4500-5000
Number of families	24	40	33	28	30	22	16	7

Ans:

Expenditure	Number of families
1000-1500	24
1500-2000	40
2000-2500	33
2500-3000	28
3000-3500	30
3500-4000	22
4000-4500	16
4500-5000	7

Modal class = 1500-2000,  $l = 1500$ , Frequencies:  $f_1 = 40$ ,  $f_0 = 24$ ,  $f_2 = 33$  and  $h = 500$

Mode formula:

$$\text{Mode} = l + \left[ \frac{(f_1 - f_0)}{(2f_1 - f_0 - f_2)} \right] \times h$$

Substitute the values in the formula, we get

$$\text{Mode} = 1500 + \left[ \frac{(40 - 24)}{(80 - 24 - 33)} \right] \times 500, \text{ Mode} = 1500 + \left[ \frac{(16 \times 500)}{23} \right]$$

$$\text{Mode} = 1500 + (8000/23) = 1500 + 347.83 = \text{Rs.}1847.83$$

Class Interval	$f_i$	$x_i$	$d_i = x_i - a$	$u_i = d_i/h$	$f_i u_i$
1000-1500	24	1250	-1500	-3	-72
1500-2000	40	1750	-1000	-2	-80
2000-2500	33	2250	-500	-1	-33
2500-3000	28	2750 = a	0	0	0
3000-3500	30	3250	500	1	30
3500-4000	22	3750	1000	2	44
4000-4500	16	4250	1500	3	48
4500-5000	7	4750	2000	4	28
Total	$f_i = 200$				$f_i u_i = -35$

$$\text{Mean} = \bar{x} = a + \left( \frac{\sum f_i u_i}{\sum f_i} \right) \times h$$

Substitute the values in the given formula

$$= 2750 + \left( \frac{-35}{200} \right) \times 500 \Rightarrow 2750 - 87.50 \Rightarrow 2662.50$$

### CASE BASED QUESTIONS (4 MARKS QUESTIONS)

1) The COVID-19 pandemic, also known as the coronavirus pandemic, is an ongoing pandemic of coronavirus disease 2019 (COVID-19) caused by severe acute respiratory syndrome coronavirus 2 (SARS-CoV-2). It was first identified in December 2019 in Wuhan, China. During survey, the ages of 80



patients infected by COVID and admitted in the one of the City hospital were recorded and the collected data is represented in the less than cumulative frequency distribution table.

Age (in year)	Below 15	Below 25	Below 35	Below 45	Below 55	Below 65
No. of patients	6	17	38	61	75	80

Based on the above information, answer the following questions.

- (i) Find the modal class interval.
- (ii) Find the median class interval
- (iii)(a) Find the modal age of the patients admitted in the hospital.

**(OR)**

- (iii)(b) Find the median age of the patients admitted in the hospital.

Ans:



2. Overweight and obesity may increase the risk of many health problems, including diabetes, heart disease, and certain cancers. The basic reason behind is the laziness, eating more junk foods and less physical exercise. The school management give instruction to the school to collect the weight data of each student. During medical check of 35 students from Class X- A, there weight was recorded as follows:



- (i) Find the median class of the given data.
- (ii) Find the modal class of the given data.
- (iii)(a) Calculate the median weight of the given data.

**(OR)**

- (iii)(b) Find the mean of the given data.

Weight (in kg)	Less than 38	Less than 40	Less than 42	Less than 44	Less than 46	Less than 48	Less than 50	Less than 52
No. of Students	0	3	5	9	14	28	32	35

Ans: 

3. India meteorological department observe seasonal and annual rainfall every year in different subdivisions of our country. It helps them to compare and analyze the results. The table given below shows sub-division wise seasonal (monsoon) rainfall (mm) in 2018

Rainfall (in mm)	200 – 400	400 – 600	600 – 800	800 -1000	1000-1200	1200-1400	1400-1600	1600-1800
Number of Sub-divisions	2	4	7	4	2	3	1	1

Based on the above information, answer the following questions.

(i) Write the modal class.

(ii)(a) Find the median of the given data.

(OR)

(ii)(b) Find the mean rainfall in this season.

(iii) If sub-division having at least 1000 mm rainfall during monsoon season, is considered good rainfall sub-division, then how many sub-divisions had good rainfall?

Ans: 



### HIGHER ORDER THINKING SKILLS

1. The average weight of A, B, C is 45 kg. If the average weight of A and B be 40 kg. and that of B and C be 43 kg, find the weight of B.

Ans: Weight of B = (A + B)'s weight + (B + C)'s weight – (A + B + C)'s weight  
 $= 2(40 \text{ kg}) + 2(43 \text{ kg}) - 3(45 \text{ kg}) = 80 + 86 - 135 = 31 \text{ kg}$

2. The median of the following data is 525. Find the values of x and y, if the total frequency is 100.

Ans:  $x = 9$  and  $y = 15$

Class interval	0 -100	100 -200	200-300	300-400	400-500	500-600	600-700	700-800	800-900	900-1000
Frequency	2	5	x	12	17	20	y	9	7	4

3. A life insurance agent found the following data for distribution of ages of 100 policy holders. Calculate the median age, if policies are only given to persons having age 18 years onwards but less than 60 years.

Age (in years)	Number of policyholders
Below 20	2
Below 25	6
Below 30	24
Below 35	45
Below 40	78
Below 45	89
Below 50	92
Below 55	98
Below 60	100

Ans: 35.76 Years

# CHAPTER 14

## PROBABILITY

### MIND MAP

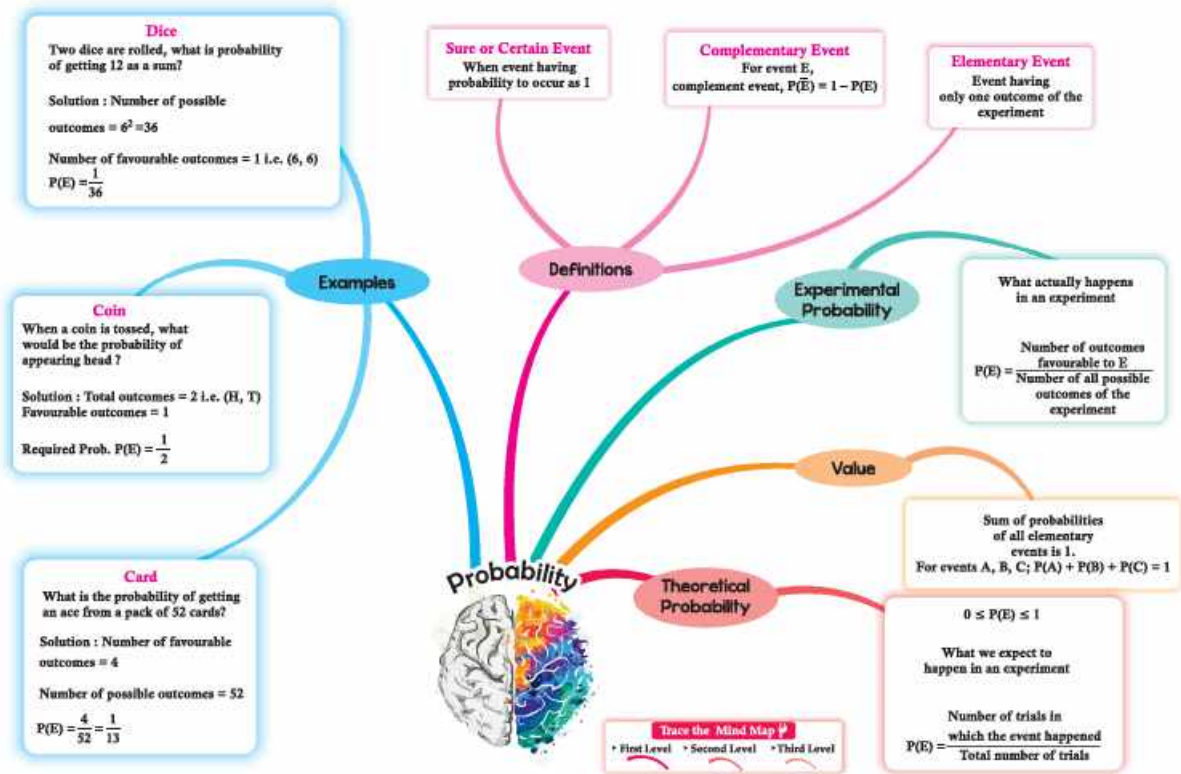

**Gist of the lesson:** The word ‘Probability’ is commonly used in our day-to-day conversation and we generally use this word even without going into details of its actual meaning. In general, people have a rough idea about its meaning. Some of the statements like:

- ❖ Probably it may rain today
- ❖ He/she may possibly join politics
- ❖ She is probably right

Probability numerically measures the degree of certainty of the occurrence of events.

### Experiments and its outcomes

An operation which can produce some well-defined outcomes is called an experiment and the results are known as outcomes.

### Random experiment

An experiment in which all possible outcomes are known, and the exact outcome cannot be predicted in advance, is called a random experiment.

### Equally likely outcomes

If an outcome of an experiment is as likely to occur as the other, then such an outcome is called equally likely.

For example: Outcomes head and tail of the experiment “tossing a fair coin” are equally likely.

### Event

A collection of one or more outcome (s) out of all possible outcomes of a random experiment is called its event.

An event having a single outcome is known as an elementary event, while an event obtained by combining two or more outcomes is called a compound event.

### Sample space

A collection of all possible outcomes of a random experiment is known as the “sample space,” which is represented by “S”.

### Occurrence of an event

An event ‘E’ associated to a random experiment is said to occur if any one of its outcomes is the result of the experiment.

### Favorable outcomes

An outcome of an experiment is said to be favorable to an event ‘E’, if its occurrence implies the occurrence of events of event ‘E’.

### Theoretical probability (or) Probability

The probability of an event ‘E’

$$P(E) = \frac{\text{Number of favourable outcomes}}{\text{Total number of possible outcomes}}$$

**Impossible event:** The probability of an impossible event (while has no chance) is zero (0).

**Sure event:** An event which is sure to occur is called a “sure event” the probability of a sure event is 1.

**Complementary event:** An event (E) is said to be complementary of event E if  $P(E) + P(\bar{E}) = 1$

### **MULTIPLE CHOICE QUESTIONS (1 MARK QUESTIONS)**

1. A card is selected at random from a deck of 52 playing cards. The probability of it being a red face card is -----

- (a)  $\frac{3}{13}$                       (b)  $\frac{2}{13}$                       (c)  $\frac{1}{2}$                       (d)  $\frac{3}{26}$

Solution: Total number of possibilities = 52

Number of red face card = 6

$$\text{Probability of red face card} = \frac{6}{52} = \frac{3}{26}$$

Ans: (d)  $\frac{3}{26}$

2. A Card is drawn at random from a pack of 52 cards. What is the probability that the card drawn is a spade (or) King?

- (a)  $\frac{1}{13}$                       (b)  $\frac{2}{13}$                       (c)  $\frac{4}{13}$                       (d)  $\frac{9}{13}$

Solution: Total number of possibilities = 52

Number of spades = 13 (including King)

and 3 kings from clubs, diamonds & hearts

$$\therefore P(\text{spade(or) king}) = \frac{13+3}{52} = \frac{16}{52} = \frac{4}{13}$$

Ans: (c) :  $\frac{4}{13}$

3. The Probability that cannot exist among the following

- (a)  $\frac{2}{3}$                       (b) -1.6                      (c) 25%                      (d) 0.7

Solution: Probability cannot be negative

Ans: b): -1.6

4. The Probability that a number selected at random from the numbers 1,2,3, ...,15 is a multiple of 4 is

- (a)  $\frac{4}{15}$                       (b)  $\frac{2}{15}$                       (c)  $\frac{1}{5}$                       (d)  $\frac{1}{3}$

Solution: Total number of possibilities = 15

Multiples of 4 are 4,8,12; (total 3)

$$P(\text{multiples of 4}) = \frac{3}{15} = \frac{1}{5}$$

Ans: (c):  $\frac{1}{5}$

5. For an event E, if  $p(E) + p(\bar{E}) = q$ , then the value of  $q^2 - 4$  is

- (a) -3                      (b) 3                      (c) 5                      (d) -5

Solution: Maximum Probability = 1 = q

$$\therefore q^2 - 4 = 1^2 - 4 = -3$$

Ans: (a) : -3

6. From the letters of the word "MOBILE", a letter is selected at random, the probability that the selected letter is a vowel is

- (a)  $\frac{3}{7}$                       (b)  $\frac{1}{6}$                       (c)  $\frac{1}{2}$                       (d)  $\frac{1}{3}$

Solution: Total Possibilities = M+O+B+I+L+E=6

Number of vowels = O+I+E=3

$$\therefore \text{Probability} = \frac{3}{6} = \frac{1}{2}$$

Ans: (c):  $\frac{1}{2}$

7. Two dice are tossed simultaneously. The probability of getting odd numbers on both dice is

- (a)  $\frac{6}{36}$                       (b)  $\frac{3}{36}$                       (c)  $\frac{12}{36}$                       (d)  $\frac{9}{36}$

Solution: Total number of Possibilities = 36

The number of favorable outcomes is (1,1), (1,3), (1,5), (3,3), (3,5), (5,1), (5,3), (5,5) = 9

$$\therefore \text{Probability is } \frac{9}{36}$$

Ans: (d):  $\frac{9}{36}$

8. Two coins are tossed simultaneously. The probability of having exactly one head is

- (a)  $\frac{1}{2}$                       (b)  $\frac{1}{4}$                       (c)  $\frac{3}{4}$                       (d) None of these

Solution: Total no. of outcomes = 4 (HH, HT, TT, TH)

Possibility of having one head = 2 (HT, TH)

$$\therefore \text{Probability is } \frac{2}{4} = \frac{1}{2}$$

Ans: (a):  $\frac{1}{2}$

9. Three rotten eggs are mixed with 12 good ones. One egg is chosen at random. The probability of choosing a rotten egg is

- (a)  $\frac{1}{15}$                       (b)  $\frac{4}{5}$                       (c)  $\frac{1}{5}$                       (d)  $\frac{2}{5}$

Solution: Total number of eggs = 3+12=15=total possibilities

Number of rotten eggs = 3

$$\therefore \text{Probability is } \frac{3}{15} = \frac{1}{5}$$

Ans: (c)  $\frac{1}{5}$

10. 17 cards are numbered as 1,2,3, -----, 17, then probability of divisible by 3 and 2 both

- (a)  $\frac{7}{17}$                       (b)  $\frac{5}{17}$                       (c)  $\frac{3}{17}$                       (d)  $\frac{2}{17}$

Solution: Total number of Possibilities = 17

Divisible by both 3 & 2 means, multiple of 6

$\therefore$  Outcomes are 6, 12

$$\text{Probability is } \frac{2}{17}$$

Ans: (d):  $\frac{2}{17}$

### ASSERTION AND REASONING QUESTIONS

**DIRECTION:** In the following questions, a statement of **Assertion (A)** is followed by a statement of **Reason (R)**. Choose the correct option

- (a) Both assertion (A) and reason (R) are true and reason (R) is the correct explanation of assertion (A)  
(b) Both assertion (A) and reason (R) are true and reason (R) is not the correct explanation of assertion (A)  
(c) Assertion (A) is true but reason (R) is false.  
(d) Assertion (A) is false but reason (R) is true.

1. **Assertion (A):** In a simultaneous throw of a pair of dice. The probability of getting a doublet is  $\frac{1}{6}$ .

**Reason (R):** Probability of an event may be negative.

Ans: (c)

2. **Assertion (A):** The probability of winning a game is 0.4, then the probability of losing it, is 0.6.

**Reason (R):**  $P(E) + P(\text{not } E) = 1$

Ans:(a)

3. **Assertion (A):** The probability of getting exactly one head in tossing a pair of coins is  $\frac{1}{2}$ .

**Reason (R):** The sample space of two coin tossed is = {HH, TT, HT, TH} = 4

Ans:(a)

4. **Assertion (A):** The probability that a leap year has 53 Sundays is  $\frac{2}{7}$ .

**Reason (R):** The probability that a non-leap year has 53 Sundays is  $\frac{5}{7}$ .

Ans. (c)

5. **Assertion (A):** The probability of getting a bad egg in a lot of 400 is 0.035. The number of good eggs in the lot is 386.

**Reason (R):** If the probability of an event is p, the probability of its complementary event will be 1-p.

Ans. (a)

6. **Assertion (A):** In a cricket match, a batsman hits a boundary 9 times out of 45 balls he plays. The probability that in a given ball, he does hit the boundary is  $\frac{4}{5}$ .

**Reason (R):**  $P(E) + P(\text{not } E) = 1$

Ans. (a)

7. **Assertion (A):** Tanvi and Manvi were born in the year 2000. The probability that they have same birthday is  $\frac{1}{366}$

**Reason (R):** Leap year has 366 days.

Ans. (a)

8. **Assertion (A):** A four-digit number is formed using the digits 1,2,5,6 and 8 without repetition. The probability that is an even number is  $\frac{3}{5}$

**Reason (R):** The units digit of even number is also an even number.

Ans:(b)

9. **Assertion (A):** A dice is rolled. The probability of getting a composite number is  $\frac{1}{3}$ .

**Reason (R):** In a throw of a dice the probability of getting a prime number is  $\frac{2}{3}$

Ans. (c)

10. **Assertion (A):** When a dice is rolled the probability of getting a number which is multiple of 3 and 5 both is 0.

**Reason (R):** The probability of an impossible event is 0.

Ans. (a)

### VERY SHORT ANSWER TYPE QUESTIONS(2 MARKS QUESTIONS)

1. There is a square board of side '2a' units circumscribing a yellow circle. Jayadev is asked to keep a dot on the above said board. Find the probability that he keeps the dot on the shaded region.

Ans. Area of square =  $(2a)^2 = 4a^2$

Area of circle =  $\pi r^2 = \pi a^2$

Difference =  $4a^2 - \pi a^2 = a^2(4 - \pi)$

Required probability = Favourable outcomes/Sample space

$$\frac{a^2(4 - \pi)}{4a^2} = \frac{(4 - \pi)}{4}$$

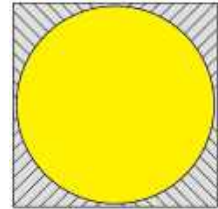

2. In an MCQ test, a student guesses the correct answer  $x$  out of  $y$  times. If the probability that the student guesses the answer to be wrong is  $\frac{2}{3}$  then what is the relation between  $x$  and  $y$ ?

Ans. According to the given information,  $P(\text{wrong}) = \frac{2}{3}$

The probability of guessing the correct answer is the complement of the probability of guessing wrong answer.

$$P(\text{correct}) = 1 - P(\text{wrong}) = 1 - \frac{2}{3}$$

$$P(\text{correct}) = \frac{1}{3}$$

Now, the probability of guessing the correct answer  $P(\text{correct})$  is the ratio of the number of correct (guesses) ( $x$ ) to the total number of guesses ( $y$ )

$$P(\text{correct}) = \frac{x}{y}$$

$$\therefore \frac{x}{y} = \frac{1}{3} \Rightarrow 3x = y \Rightarrow y = 3x$$

3. A dice is thrown twice. Find the probability of getting 4, 5 or 6 in the first throw and 1, 2, 3 or 4 in the second throw.

Ans. Total number of outcomes on throwing a dice twice = 36

Here, favourable outcomes =  $\{(4, 1), (4, 2), (4, 3), (4, 4), (5, 1), (5, 2), (5, 3), (5, 4), (6, 1), (6, 2), (6, 3), (6, 4)\}$

$\therefore$  Number of favourable outcomes = 12

$$\therefore \text{Required probability} = \frac{12}{36} = \frac{1}{3}$$

4. A school has five houses A, B, C, D and E. A class has 23 students, 4 from house A, 8 from house B, 5 from house C, 2 from house D and the rest from house E. A single student is selected at random to be the class monitor. What is the probability that the selected student is not from houses A, B and C?

Ans. Total no. of students = 23

No. of students from houses A, B and C =  $4 + 8 + 5 = 17$

$\therefore$  Remaining no. of students =  $23 - 17 = 6$

$\therefore$  Required probability = No. of students, not from A, B and C / Total no. of students houses =  $\frac{6}{23}$

5. A card is drawn from a well-shuffled deck of 52 playing cards. What is the probability that the card will not be an ace?

Ans. Total number of cards = 52

Number of non ace card =  $52 - 4 = 48$

$$\therefore \text{Required probability} = \frac{48}{52} = \frac{12}{13}$$

6. A bag has 5 white marbles, 8 red marbles and 4 purple marbles. If we take a marble randomly, then what is the probability of not getting purple marble?

Ans: Total number of purple marbles = 4

Total number of marbles in bag =  $5 + 8 + 4 = 17$

Probability of getting not purple marbles =  $\frac{13}{17} = 0.77$

7. Out of 200 bulbs in a box, 12 bulbs are defective. One bulb is taken out at random from the box. What is the probability that the drawn bulb is not defective?

Ans. Total no. of bulbs = 200

No. of defective bulbs = 12

No. of non-defective bulbs =  $200 - 12 = 188$

So,  $P(\text{Getting a non-defective bulbs}) = \frac{188}{200} = \frac{48}{50}$

8. An integer is chosen at random between 1 and 100. Find the probability that it is:

(i) divisible by 8.

(ii) not divisible by 8.

Ans. (i) The integers divisible by 8 between 1 and 100 are 8, 16, 24, 32, 40, 48, 56, 64, 72, 80, 88, 96, i.e. 12

Total outcomes = 98

$$(i) P(\text{divisible by } 8) = \frac{12}{98} = \frac{6}{49}$$

$$(ii) P(\text{not divisible by } 8) = \frac{98-12}{98} = \frac{86}{98} = \frac{43}{49}$$

9. A ticket is drawn at random from a bag containing tickets numbered from 1 to 40. Find the probability that the selected ticket has a number which is a multiple of 5.

Ans: Total number of tickets = 40

Multiple of 5 are 5, 10, 15, 20, 25, 30, 35, 40

$$P(\text{a number which is a multiple of } 5) = \frac{8}{40} = \frac{1}{5}$$

10. Find the probability that a number selected at random from the numbers 1, 2, 3, ..., 35 is a

Prime number

ii) Multiple of 7

Ans: (i) Prime numbers are 2, 3, 5, 7, 11, 13, 17, 19, 23, 29, 31 Total-11 prime numbers

$$P(\text{Prime}) = \frac{11}{35}$$

(ii) Multiples of 7 are 7, 14, 21, 28, 35 Total-5 numbers

$$P(\text{Multiple of } 7) = \frac{5}{35} = \frac{1}{7}$$

### **SHORT ANSWER TYPE QUESTIONS (3 MARKS QUESTIONS)**

1. A lot consists of 144 ball pens of which 20 are defective. The customer will buy a ball pen if it good, but will not buy a defective ball pen. The shopkeeper draws one pen at random from the lot and gives it to the consumer. What is the probability that

(i) customer will buy the ball pen

(ii) customer will not buy the ball pen

Ans. Total ball pens = 144

Defective ball pens = 20

Good ball pens =  $144 - 20 = 124$

$$(i) \text{ Probability that the customer will buy the ball pen} = \frac{124}{144} = \frac{31}{36}$$

$$(ii) \text{ Probability that the customer will not buy the ball pen} = \frac{20}{144} = \frac{5}{36}$$

2. All the black face cards are removed from a pack of 52 playing cards. The remaining cards are well shuffled and then a card is drawn at random. Find the probability of getting (i) face card (ii) red card (iii) black card.

Ans: When all the black face cards are removed,

Remaining number of cards =  $52 - 6 = 46$

(i) Number of face cards in the remaining deck = 6

$$\therefore P(\text{getting a face card}) = \frac{6}{46} = \frac{3}{23}$$

(ii) Number of red cards in the remaining deck = 26

$$\therefore P(\text{getting a red card}) = \frac{26}{46} = \frac{13}{23}$$

(iii) Number of black cards in the remaining deck = 20

$$\therefore P(\text{getting a black card}) = \frac{20}{46} = \frac{10}{23}$$

3. Two dice are thrown at the same time. What is the probability that the sum of the two numbers appearing on the top of the dice is

(i) at least 9?

(ii) 7?

(iii) less than or equal to 6?

Ans: (i) Number of outcomes with sum of the numbers is at least 9 = 10

$$\therefore \text{Required Probability} = \frac{10}{36} = \frac{5}{18}$$

(ii) Number of outcomes with sum of the numbers 7 = 6

$$\therefore \text{Required Probability} = \frac{6}{36} = \frac{1}{6}$$

(iii) Number of outcomes with sum of the numbers less than or equal to 6 = 36

$$\therefore \text{Required Probability} = \frac{15}{36} = \frac{5}{12}$$

4. A bag contains 12 balls out of which  $x$  are white.

(i) If one ball is drawn at random, what is the probability that it will be a white ball?

(ii) If 6 more white balls are put in the bag, the probability of drawing a white ball will be double than that in (i). Find  $x$ .

Ans.  $n(S) = 12$

(i) Let  $A$  be the event of drawing a white ball  $n(A) = x$ ,  $P(A) = \frac{x}{12}$

(ii) Number of white balls =  $x + 6$

Total number of balls =  $12 + 6 = 18$ .

Let  $B$  be the event of drawing a white ball

$$\therefore n(B) = x + 6, P(B) = \frac{x+6}{18}$$

According to the question,  $P(B) = 2P(A)$

$$\Rightarrow \frac{x+6}{18} = 2 \times \frac{x}{12}$$

$$\Rightarrow 6x + 36 = 18x$$

$$\Rightarrow 12x = 36 \Rightarrow x = 3$$

5. One card is drawn from a well shuffled deck of 52 cards. Find the probability of getting

(i) a face card or a black card

(ii) neither an ace nor a king

(iii) a jack and a black card

Ans. Total number of playing cards = 52

(i) Favourable cases for a face card or a black card are 32 ( $12 + 26 - 6$ )

$$\therefore \text{Probability of drawing a king or a jack} = \frac{32}{52} = \frac{8}{13}$$

(ii) Favourable cases for neither ace nor king card are 44 ( $52 \text{ cards} - 4 \text{ aces} - 4 \text{ king}$ )

$$\therefore \text{Probability of drawing a non-ace} = \frac{44}{52} = \frac{11}{13}$$

(iii) Favourable cases for jack and black card are 2

$$\therefore \text{Probability of drawing a red card} = \frac{2}{52} = \frac{1}{26}$$

6. Two different dice are thrown together. Find the probability that the numbers obtained:

(a) have a sum less than 7

(b) have a product less than 16

(c) is a doublet of odd numbers.

Ans. The outcomes when two dice are thrown together, are:

(1, 1), (1, 2), (1, 3), (1, 4), (1, 5), (1, 6),

(2, 1), (2, 2), (2, 3), (2, 4), (2, 5), (2, 6),

(3, 1), (3, 2), (3, 3), (3, 4), (3, 5), (3, 6),

(4, 1), (4, 2), (4, 3), (4, 4), (4, 5), (4, 6),

(5, 1), (5, 2), (5, 3), (5, 4), (5, 5), (5, 6),

(6, 1), (6, 2), (6, 3), (6, 4), (6, 5), (6, 6),

∴ Total number of outcomes = 36

(a) Favourable outcomes are (1, 1), (1, 2), (1, 3), (1, 4), (1, 5), (2, 1), (2, 2), (2, 3), (2, 4), (3, 1), (3, 2), (3, 3), (4, 1), (4, 2) and (5, 1).

∴ Number of favourable outcomes = 15

∴ Required probability =  $\frac{15}{36} = \frac{5}{12}$

(b) Favourable outcomes are (1, 1), (1, 2), (1, 3), (1, 4), (1, 5), (1, 6), (2, 1), (2, 2), (2, 3), (2, 4), (2, 5), (2, 6), (3, 1), (3, 2), (3, 3), (3, 4), (3, 5), (4, 1), (4, 2), (4, 3), (5, 1), (5, 2), (5, 3), (6, 1) and (6, 2).

∴ Number of favourable outcomes = 25

∴ Required probability =  $\frac{25}{36}$

(c) Favourable outcomes are (1, 1), (3, 3) and (5, 5)

∴ Number of favourable outcomes = 3

∴ Required probability =  $\frac{3}{36} = \frac{1}{12}$

7. A box contains 19 balls bearing numbers 1, 2, 3, ....., 19. A ball is drawn at random from the box. What is the probability that the number on the ball is

(i) a prime number

(ii) divisible by 3 or 5

(iii) neither divisible by 5 nor by 10

Ans. Total number of balls = 19

(i) Prime numbers from 1 to 19 are 2, 3, 5, 7, 11, 13, 17, 19 = Total 8 prime numbers

∴ Probability of drawing a prime number =  $\frac{8}{19}$

(ii) Numbers divisible by 3 or 5 are 3, 6, 9, 15, 18, 10, 5, 12 = Total 8 numbers

∴ Probability of drawing a number divisible by 3 or 5 =  $\frac{8}{19}$

(iii) Number divisible by 5 and 10 are 5, 10, 15 = Total 3

∴ Numbers which are neither divisible by 5 nor 10 are  $19 - 3 = 16$

∴ Probability of drawing a number which is neither divisible by 5 nor by 10 =  $\frac{16}{19}$

8. Two dice are thrown simultaneously. What is the probability that

(a) 6 will not come up on either of them?

(b) 6 will come up on at least one?

(c) 6 will come up at both dice?

Ans: Total no. of outcomes = 36

(a) Number of outcomes in which 6 will not come up on either of them = 25.

∴ Required Probability =  $\frac{25}{36}$

(b) Number of outcomes in which 6 will come up at least one die = 11.

∴ Required Probability =  $\frac{11}{36}$

(c) Number of outcomes in which 6 will come up at both die = 1.

∴ Required Probability =  $\frac{1}{36}$

9. A bag contains 3 red balls and 5 black balls. A ball is drawn at random from the bag. What is the probability that the ball drawn is: (i) red? (ii) not red?

Ans. Total number of balls =  $3 + 5 = 8$

(i) Number of red balls = 3

Hence, P ( red ball) =  $\frac{3}{8}$

(ii) Number of not red balls = 5

Hence,  $P(\text{not red ball}) = \frac{5}{8}$

10. An integer is chosen at random between 1 and 100. Find the probability that it is:

(i) divisible by 8.

(ii) not divisible by 8.

Ans. (i) The integers divisible by 8 between 1 and 100 are 8, 16, 24, 32, 40, 48, 56, 64, 72, 80, 88, 96, i.e. 12

Total outcomes = 98

$P(\text{divisible by 8}) = \frac{12}{98} = \frac{6}{49}$

(ii)  $P(\text{not divisible by 8}) = \frac{98-12}{98} = \frac{86}{98} = \frac{43}{49}$

### **LONG ANSWER TYPE QUESTIONS (5 MARKS QUESTIONS)**

1. A child's game has 8 triangles of which 3 are blue and rest are red, and 10 squares of which 6 are blue and rest are red. One piece is lost at random. Find the probability that it is a

(i) triangle            (ii) square            (iii) square of blue colour            (iv) triangle of red colour

Ans: Total number of pieces =  $8 + 10 = 18$

(i) No. of triangles = 8. Hence,  $P(\text{triangle is lost}) = \frac{8}{18} = \frac{4}{9}$

(ii) No. of squares = 10. Hence,  $P(\text{square is lost}) = \frac{10}{18} = \frac{5}{9}$

(iii) No. of squares of blue colour = 6. So,  $P(\text{square of blue colour is lost}) = \frac{6}{18} = \frac{1}{3}$

(iv) No. of triangles of red colour =  $8 - 3 = 5$ . So,  $P(\text{triangle of red colour is lost}) = \frac{5}{18}$

2. From a pack of 52 playing cards, jacks, queens, kings and aces of red colour are removed. From the remaining a card is drawn at random. Find the probability that the card drawn is (i) a black queen (ii) a red card (iii) a face card (iv) a spade card

Ans: From the total playing 52 cards, red coloured jacks, queen, kings and aces are removed (i.e., 2 jacks, 2 queens, 2 kings, 2 aces)  $\therefore$  Remaining cards =  $52 - 8 = 44$

(i) Favourable cases for a black queen are 2 (i.e., queen of club or spade)

$\therefore$  Probability of drawing a black queen =  $\frac{2}{44} = \frac{1}{22}$

(ii) Favourable cases for red cards are  $26 - 8 = 18$  (as 8 cards have been removed) (i.e. 9 diamonds + 9 hearts)

$\therefore$  Probability of drawing a red card =  $\frac{18}{44} = \frac{9}{22}$

(iii) Favourable cases for a face card are 6 (i.e. 2 black jacks, queens and kings each)

$\therefore$  Probability of drawing a face card =  $\frac{6}{44} = \frac{3}{22}$

(iv) Favourable cases for a spade card are 13

$\therefore$  Probability of drawing a spade card =  $\frac{13}{44}$

3. A box contains cards bearing numbers from 6 to 70. If one card is drawn at random from the box, find the probability that it bears

(i) a one digit number.

(ii) a number divisible by 5.

(iii) an odd number less than 30.

(iv) a composite number between 50 and 70.

Ans: Number of cards in the box = 65

(i) Cards bearing one digit numbers are 6, 7, 8, 9

Number of such cards = 4

$\therefore$  Probability of card bears a one digit number =  $\frac{4}{65}$

(ii) B = Number on the cards is divisible by 5

∴ Cards favourable to B are 10, 15, 20, 25, 30, 35, 40, 45, 50, 55, 60, 65, 70

$$\therefore P(B) = \frac{13}{65} = \frac{1}{5}$$

(iii) C = Cards with an odd number less than 30 i.e. 7, 9, 11, 13, 15, 17, 19, 21, 23, 25, 27, 29

$$P(C) = \frac{12}{65}$$

(iv) D : Card with composite number between 50 and 70

i.e. 51, 52, 54, 55, 56, 57, 58, 60, 62, 63, 64, 65, 66, 68, 69

$$\therefore P(D) = \frac{15}{65} = \frac{3}{13}$$

4. From a pack of 52 playing cards, Jacks and Kings of red colour and Queens and Aces of black colour are removed. The remaining cards are mixed and a card is drawn at random. Find the probability that the drawn card is:

(a) a black queen.

(b) a card of red colour.

(c) a Jack of black colour.

(d) a face card.

Ans. Number of cards removed =  $(2 + 2 + 2 + 2) = 8$

Total number of remaining cards =  $(52 - 8) = 44$

Now, there are 2 jacks, 2 kings of black colour and 2 queens, 2 aces of red colour left.

(a) Number of black queens = 0

$$\therefore P(\text{getting a black queen}) = \frac{0}{44} = 0$$

(b) Number of red cards =  $26 - 4 = 22$

$$\therefore P(\text{getting a red card}) = \frac{22}{44} = \frac{1}{2}$$

(c) Number of jacks of black colour = 2

$$\therefore P(\text{getting a black jack}) = \frac{2}{44} = \frac{1}{22}$$

(d) We know that jacks, queens and kings are face cards.

∴ Number of remaining face cards =  $(2 + 2 + 2) = 6$

$$\therefore P(\text{getting a face card}) = \frac{6}{44} = \frac{3}{22}$$

5. Red Queens and black jacks are removed from a pack of 52 playing cards. A card is drawn at random from the remaining cards, after reshuffling them. Find the probability that the drawn card is

(i) a king

(ii) red colour

(iii) a face card

(iv) a queen

Ans: i)  $\frac{1}{12}$

ii)  $\frac{1}{2}$

iii)  $\frac{1}{6}$

iv)  $\frac{1}{24}$

### **CASE BASED QUESTIONS (4 MARKS QUESTIONS)**

1. Computer Based Learning (CBL) refers to any teaching methodology that makes use of computers for information transmission. At an elementary school level, computer applications can be used to display multimedia lesson plans. A survey was done on 1000 elementary and secondary schools of Assam and they were classified by the number of computers they had.



Number of Computers	1 – 10	11 – 20	21 – 50	51 – 100	101 and more
Number of Schools	250	200	290	180	80

One school is chosen at random.

Based on the given information, solve the following questions:

- (i) Find the probability that the school chosen at random has more than 100 computers.  
(ii) Find the probability that the school chosen at random has 50 or fewer computers.

(OR)

Find the probability that the school chosen at random has no more than 20 computers.

- (iii) Find the probability that the school chosen at random has 10 or less than 10 computers.

Ans. (i) Total number of possible outcomes = Number of schools = 1000

Number of favourable outcomes = Number of schools has more than 100 computers = 80

$$\therefore \text{Required probability} = \frac{80}{1000} = \frac{2}{25}$$

(ii) Total number of possible outcomes = Number of schools = 1000

Number of favourable outcomes = Number of schools has 50 or fewer computers = 250 + 200 + 290 = 740

$$\therefore \text{Required probability} = \frac{740}{1000} = \frac{37}{50}$$

(OR)

Total number of possible outcomes = Number of schools = 1000

Number of favourable outcomes = Number of schools has no more than 20 computers = 250 + 200 = 450

$$\therefore \text{Required probability} = \frac{450}{1000} = \frac{9}{20}$$

(iii) Total number of possible outcomes = Number of schools = 1000

Number of favourable outcomes = Number of schools has 10 or less than 10 computers = 250

$$\therefore \text{Required probability} = \frac{250}{1000} = \frac{1}{4}$$

2. A middle school decided to run the following spinner game as a fund-raiser on Christmas

Making Purple: Spin each spinner once. Blue and red make purple. So, if one spinner shows Red (R) and another Blue (B), then you 'win'. One such outcome is written as 'RB'.

Based on the given information, solve the following questions:

- (i) List all possible outcomes of the game.

- (ii) Find the probability of 'Making Purple'.

- (iii) For each win, a participant gets ₹ 10, but if he/she loses, he/she has to pay ₹ 5 to the school. If 99 participants played, calculate how much fund could the school have collected.

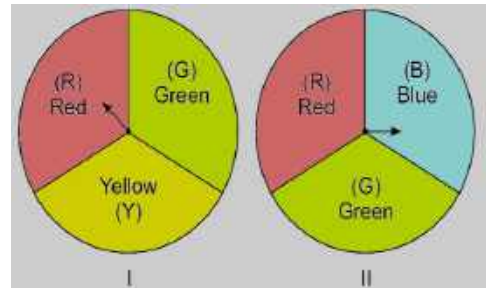

(OR)

If the same amount of ₹ 5 has been decided for winning or losing the game, then how much fund had been collected by school? (Number of participants = 99)

Ans. (i) Spinner I      Spinner II

Red (R) – Red (R) (RR)

Red (R) – Blue (B) RB,

Red (R) – Green (G) RG,

Green (G) – Red (R) GR,

Green (G) – Blue (B) GB,

Green (G) – Green (G) GG,

Yellow (Y) – Red (R) YR,

Yellow (Y) – Blue (B) YB,

Yellow (Y) – Green (G) YG}

Total number of outcomes = 9

- (ii) X = {RB}

Favourable outcomes = 1

$$P(\text{making purple}) = \frac{1}{9}$$

(iii) Number of participants = 99

$$\text{Winning number} = \frac{1}{9} \times 99 = 11$$

School has to pay Amount = ₹ (-10) × 11 = ₹ (-110)

$$\text{Loss number} = 99 - 11 = 88$$

$$\text{Amount pay to school} = ₹ 5 \times 88 = ₹ 440$$

$$\text{Net} = 440 - 110 = 330$$

∴ So, the school most likely collected ₹ 330

(OR)

The school collected the fund

$$= ₹ 5 \times \text{Number of losers} - ₹ 5 \times \text{Number of winners}$$

$$= 5 \times 88 - 5 \times 11$$

$$= 440 - 55 = ₹ 385$$

3. Tushara took a pack of 52 cards. She kept aside all the black face cards and shuffled the remaining cards well. Based on the above information answer the following questions.

(i) Write the number of total possible outcomes.

(ii) She draws a card from the well-shuffled pack of remaining cards.

What is the probability that the card is a face card?

(iii) Write the probability of drawing a black card

(OR)

(iii) What is the probability of getting neither a black card nor an ace card?

Ans: (i) Total possible outcomes = 52 - 6 = 46

(ii) Number of favourable outcomes = 6

$$P(\text{face card}) = \frac{6}{46} = \frac{3}{23}$$

(iii) Number of black cards in the shuffled cards = 13 + 7 = 20

$$P(\text{black card}) = \frac{20}{46} = \frac{10}{23}$$

(OR)

$$\text{Number of black cards and ace} = 20 + 2 = 22$$

$$\therefore \text{Number of favorable outcomes} = 46 - 22 = 24$$

$$P(\text{neither a black card nor an ace}) = \frac{24}{46} = \frac{12}{23}$$



**EXERCISES AND ANSWERS (ALL CHAPTERS)**



**SAMPLE QUESTION PAPERS (1- 4)  
STANDARD MATHEMATICS 2025-26**



**SAMPLE QUESTION PAPERS (1- 4)  
BASIC MATHEMATICS 2025-26**



## USEFUL LINKS

CBSE CURRICULUM

[https://cbseacademic.nic.in/curriculum\\_2026.html](https://cbseacademic.nic.in/curriculum_2026.html)

NCERT TEXT BOOK

<https://ncert.nic.in/textbook.php?jemh1=0-14>

CBSE QUESTION PAPER 2024 – 25

<https://www.cbse.gov.in/cbsenew/question-paper.html>

CBSE MARKING SCHEME 2024 – 25

<https://www.cbse.gov.in/cbsenew/marking-scheme.html>

CBSE SAMPLE PAPER 2024 -25

[https://cbseacademic.nic.in/sqp\\_classx\\_2024-25.html](https://cbseacademic.nic.in/sqp_classx_2024-25.html)

NCERT YOUTUBE LESSONS

<https://www.youtube.com/@NCERTOFFICIAL/search?query=CLASS%2010%20MATHEMATICS>

INDIAN MATHEMATICIANS

<https://www.youtube.com/@NCERTOFFICIAL/search?query=INDIAN%20MATHEMATICIANS>